



FOCUS LCDs

LCDs MADE SIMPLE®

Ph. 480-503-4295 | NOPP@FocusLCDs.com

TFT | OLED | CHARACTER | GRAPHIC | UWVD | SEGMENT | CUSTOM

TFT Display Module

Part Number

E50GE-I-RW420-C

Overview:

- 5.0-Inch TFT (120.7x76.3mm)
- 800x480 Pixels
- RGB Interface
- Wide Temp Range
- All View
- Transmissive, IPS
- Capacitive Touch Panel
- 420 Nits
- TFT IC: ST7262
- RoHS Compliant

1. General Description and Features

E50GE-I-RW420-C is a TN (Transmissive) type color active matrix TFT (Thin Film Transistor) liquid crystal display (LCD) that uses amorphous silicon TFT as a switching device. This model is composed of a TFT-LCD module, a driver circuit and a back-light unit. The resolution of a 5.0" contains 800RGBx480 dots. The following table described the features of E50GE-I-RW420-C.

Item	Specification	Unit
Screen Size	5.0 inches	Diagonal
Display Resolution	800 RGB (H) x 480 (V)	Dot
Active Area	108 (H) x 64.8 (V)	mm
Outline Dimension	120.7(W) x 76.3(H) x 5.07 (D)	mm
Display Mode	Normally Black / Transmissive	--
Pixel Arrangement	RGB Vertical Stripe	--
TP	Capacitive	--
Viewing Direction	ALL	
Drive IC	ST7262	--

2. Mechanical Information

Item		Min.	Typ.	Max.	Unit	Note
Module Size	Horizontal (H)	120.5	120.7	120.9	mm	--
	Vertical (V)	76.1	76.3	76.5	mm	(1)
	Thickness (T)	4.87	5.07	5.27	mm	(2)
Weight		--	N/A	--	g	--

Note

(1) Does not include FPC. Refer to the Outline Dimension for further information.

(2) Back-light unit are included.

3. Outline Dimensions

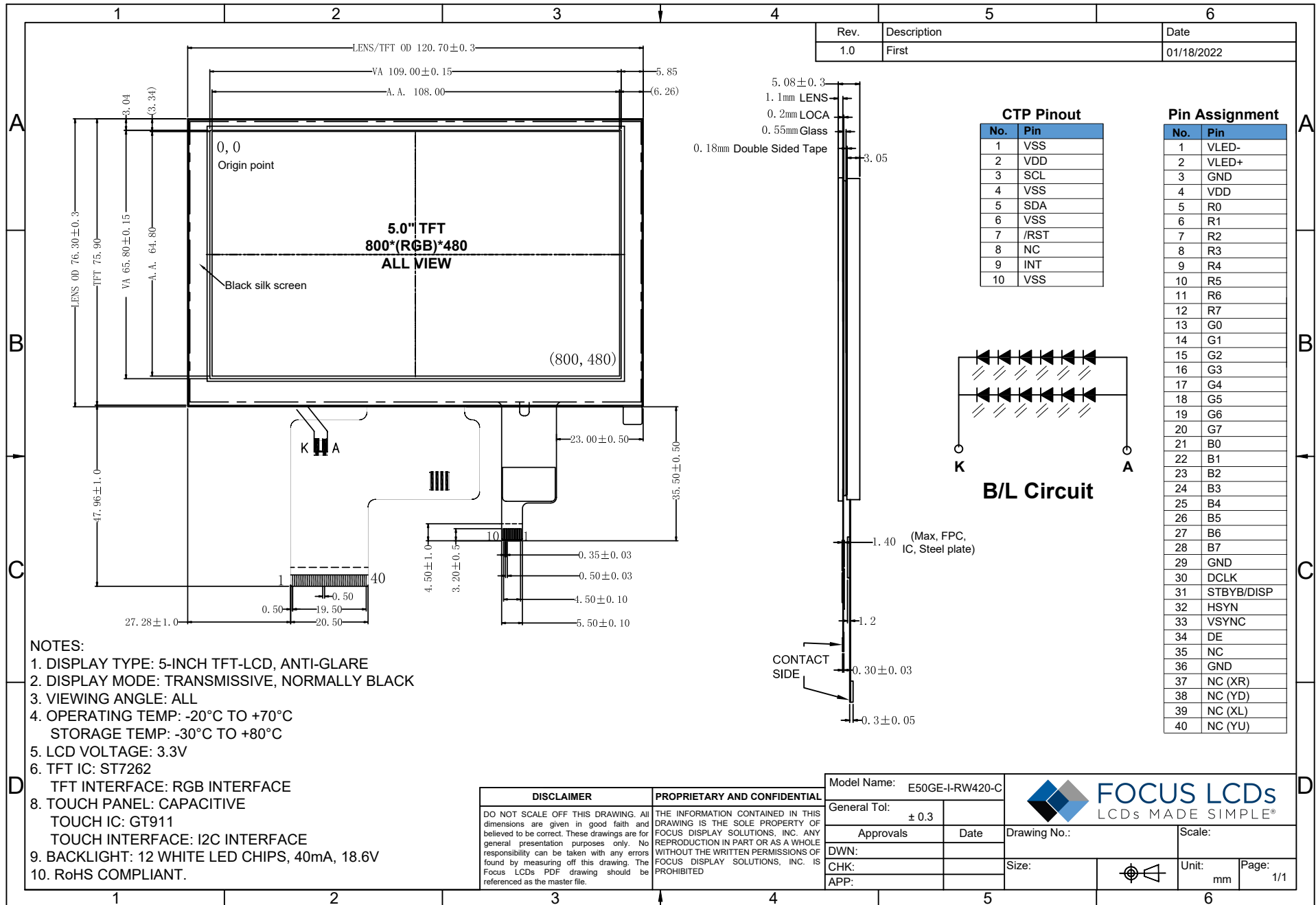

4. Input Terminal Pin Assignment

PIN	SYMBOL	I/O/P	FUNCTION
1	LED_K	P	BACKLIGHT LED GROUND
2	LED_A	P	BACKLIGHT LED POWER
3	GND	P	GROUND
4	VDD	P	SUPPLY VOLTAGE
5-12	R0-R7	I/O	RED DATA
13-20	G0-G7	I/O	GRREN DATA
21-28	B0-B7	I/O	BLUE DATA
29	GND	P	GROUND
30	DCLK	I	Clock for input data. Data latched at rising/falling edge of this signal. Default is falling edge.
31	DISP	P	DISPLAY ON/OFF
32	HSYN	I	Horizontal sync input in digital parallel RGB. Negative polarity. ¹
33	VSYN	I	Vertical sync input in digital parallel RGB. Negative polarity.
34	DE	I	Input data enable control. When DE mode, active High to enable data input. (Normally pull low)
35	NC	-	NO CONNECT
36	GND	P	GROUND
37	NC	-	NO CONNECT
38	NC	-	NO CONNECT
39	NC	-	NO CONNECT
40	NC	-	NO CONNECT

5. Electrical Specifications

5.1 Absolute Max. Ratings

If the operating condition exceeds the following absolute maximum ratings, the TFT LCD module may be damaged permanently.

(Ta=25±2°C, V_{SS}=GND=0)

Item	Symbol	Min.	Max.	Unit	Note
Storage temperature	T _{STG}	-30	80	°C	(1)
Operating temperature	T _{OPR}	-20	70	°C	(1,2,3)

Note (1) 95 % RH Max. (40 °C ≥ Ta). Maximum wet-bulb temperature at 39 °C or less. (Ta > 40 °C)
 No condensation.

Note (2) In case of below 0°, the response time of liquid crystal (LC) becomes slower and the color of panel becomes darker than normal one. Level of retardation depends on temperature, because of LC's character

Note (3) Only operation is guaranteed at operating temperature. Contrast, response time, another display quality are evaluated at +25°C.

5.2 DC Electrical Characteristics of the TFT LCD

(Ta=25±2°C, V_{SS}=GND=0)

Item	Symbol	Min.	Typ.	Max.	Unit	Remark
System Voltage	VDD	2.8	3.3	3.6	V	
Interface Operation Voltage	VDDI	1.8	3.3	3.6	V	
Input Voltage for logic	H Level	V _{IH}	0.7xVDD	-	VDD	V
	L Level	V _{IL}	0	-	0.3xVDD	V
Power Supply current	I _{DD}	--	-	(200)	mA	
Gate driver high voltage	V _{GH}	----	----	----	----	
Gate driver low voltage	V _{GL}	----	----	----	----	
Input signal voltage	V _{COM}	----	----	----	----	

5.3 Electrical Absolute Rating

5.3.1 TFT-LCD Module

(Voltage Referenced to VSS)

Item	Symbol	Value		Unit	Condition
		Min.	Max.		
Digital Power Supply Voltage	VDD	VSS-0.3	3.6	V	
Interface Operation Voltage	VDDI	---	----	V	
Gate driver high voltage	VGH	---	----	V	
Gate driver low voltage	VGL	---	----	V	
LED Reverse Voltage	VR	---	3.6	V	Each LED
LED Forward Current	IF	---	20	mA	Each LED

Note 1: The absolute maximum rating values of this product are not allowed to be exceeded at anytime. Should a module be used with any of the absolute maximum ratings exceeded, the characteristics of the module may not be recovered, or in an extreme case, the module may be permanently destroyed.

6. Electrical Characteristics

6.1 Backlight Unit

The back-light system is an edge-lighting type (Light Emitting Diode).

(Ta=25±2°C)

Item	Symbol	Value			Unit	Condition
		Min.	Typ.	Max.		
LED Voltage	VF	16.2	18.6	20.4	V	
LED Current	IF	-	40	-	mA	
Power Consumption	P _{BL}	-	-	-	mW	

Note (1) Where I_F = 40mA, V_F = 18.6V P_{BL} = V_F × I_F

7. Optical Characteristics

The following items are measured under stable conditions. The optical characteristics should be measured in a dark room or equivalent state with the methods.

Measuring equipment: BM-7A

Item	Symbol	Condition	Min	Type	Max	Unit	Note	
Brightness	B		350	420	--	cd/m ²		
Response time	T _r	θ=25°	-	10	15	ms		
	T _f		--	20	25	ms		
Contrast ratio	CR	At optimized viewing angle	--	800	--	--		
Luminance Uniformity	ΔL		75	80		%		
Color Chromaticity (CIE 1931)	White	W _x	θ=0° Normal Viewing Angle	0.27	0.32	0.37	--	BM-7A
		W _y		0.29	0.34	0.39		
Viewing Angle (6H)	Hor.	θ _R	CR≥10	70	80	--	Degree	
		θ _L		70	80	--		
	Ver.	θ _U		70	80	--		
		θ _D		70	80	--		

Optical Specification Reference Notes:

(1) Definition of Viewing Angle:

The viewing angle is the angle at which the contrast ratio is greater than 10. The viewing angles are determined for the horizontal or 3,9 o'clock direction and the vertical or 6,12 o'clock direction with respect to the optical axis which is normal to the LCD surface.

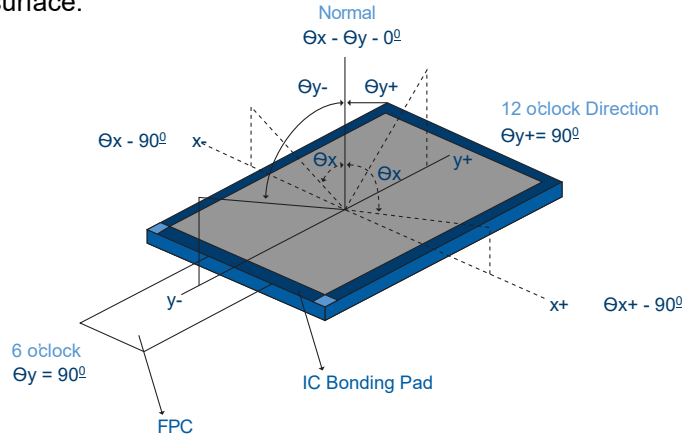

(2) Definition of Contrast Ratio:

Measured at the center point of panel. The contrast ratio (Cr) measured on a module, is the ratio between the luminance (Lw) in a full white area (R=G=B=1) and the luminance (Ld) in a dark area (R=G=B=0).

$$Cr = \frac{Lw}{Ld}$$

(3) Definition of Transmittance (T%):

The transmittance of the panel including the polarizers is measured with electrical driving. The equation for transmittance Tr is:

$$Tr = \frac{It}{Io} \times 100\%$$

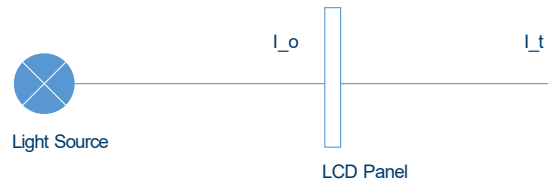

Io = the brightness of the light source.

It = the brightness after panel transmission

(4) Definition of Response Time (TR, TF):

The rise time 'Tr' is defined as the time for luminance to change from 90% to 10% as a result of a change of the electrical condition. The fall time 'Tf' is defined as the time for luminance to change from 10% to 90% as a result of a change of the electrical condition.

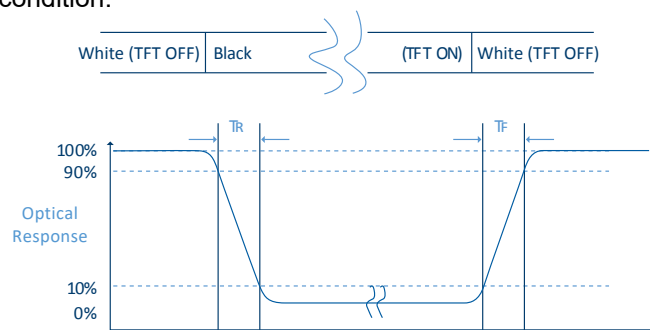

(5) Definition of Color Gamut:

Measuring machine CFT-01. NTSC's Primaries: R(x,y,Y), G(x,y,Y), B(x,y,Y). FPM520 of Westar Display Technologies, INC., which utilized SR-3 for Chromaticity and BM-5A for other optical characteristics. The color chromaticity shall be calculated from the spectral data measured with all pixels first in red, green, blue and white. Measurements shall be made at the center of the panel.

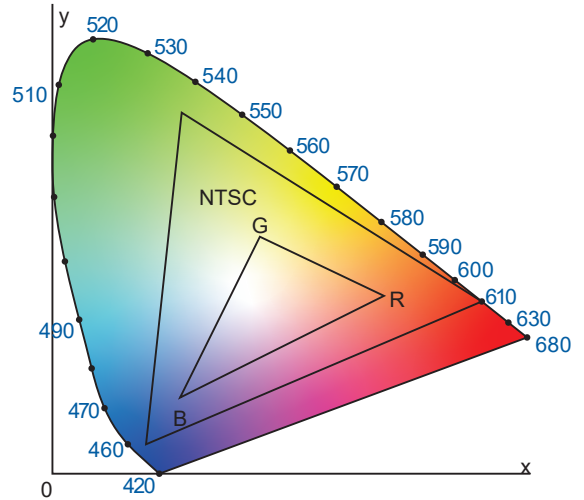
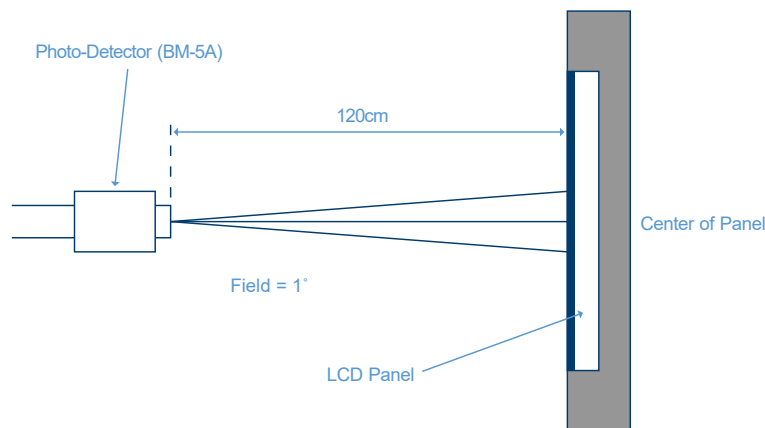
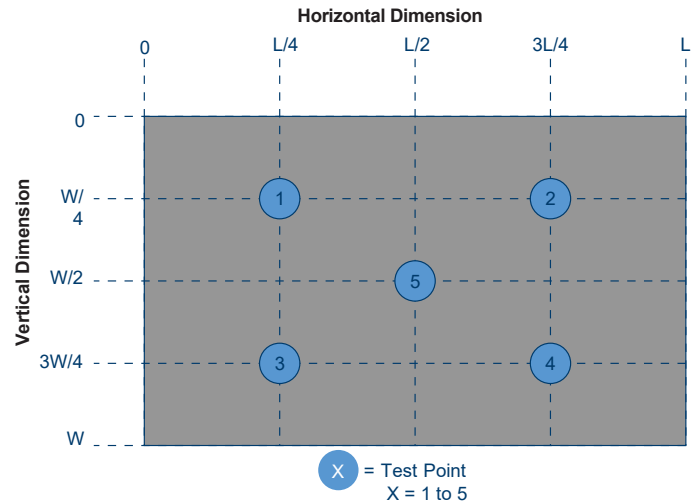
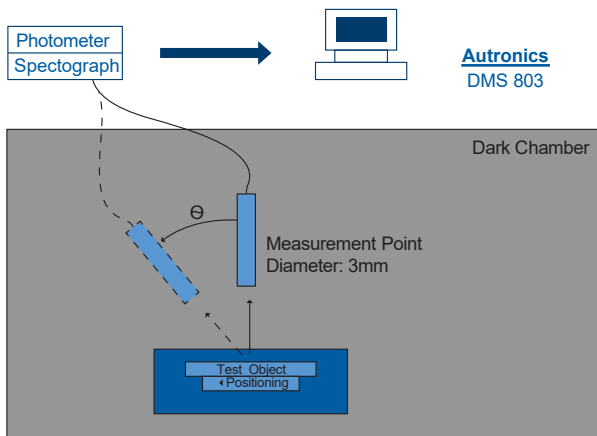

Fig. 1931 CIE Chromacity Diagram

Color Gamut: $S = \frac{\text{Area of RGB Triangle}}{\text{Area of NTSC Triangle}} \times 100\%$

(6) Definition of Optical Measurement Setup:

The LCD module should be stabilized at a given temperature for 20 minutes to avoid abrupt temperature change during measuring. In order to stabilize the luminance, the measurement should be executed after lighting backlight for 20 minutes.



8. Interface Timing

Item	Symbol	Values			Unit	Remark
		Min.	Typ.	Max.		
Horizontal Display Area	thd	-	800	-	DCLK	
DCLK Frequency	fclk	26.4	33.3	46.8	MHz	
One Horizontal Line	th	862	1056	1200	DCLK	
HS pulse width	thpw	1		40	DCLK	
HS Blanking	thb	46	46	46	DCLK	
HS Front Porch	thfp	16	210	354	DCLK	

Item	Symbol	Values			Unit	Remark
		Min.	Typ.	Max.		
Vertical Display Area	tvd	-	480	-	TH	
VS period time	tv	510	525	650	TH	
VS pulse width	tvpw	1	-	20	TH	
VS Blanking	tvb	23	23	23	TH	
VS Front Porch	tvfp	7	22	147	TH	



Figure 3. 1 Horizontal input timing diagram.

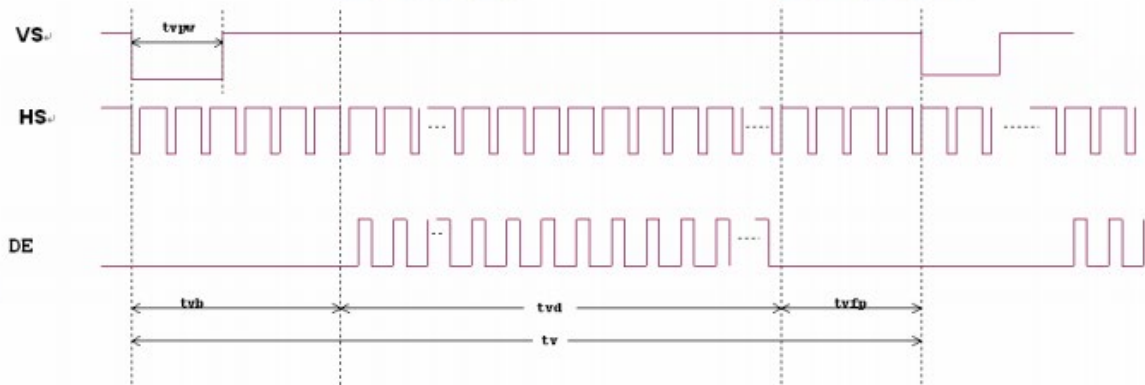

9. Reliability Condition for LCD

No change on display and in operation under the following test condition.

Condition: Unless otherwise specified, tests will be conducted under the following condition.

Temperature: $20 \pm 5^\circ\text{C}$ Humidity: $65 \pm 5\% \text{RH}$

Tests will be not conducted under functioning state.

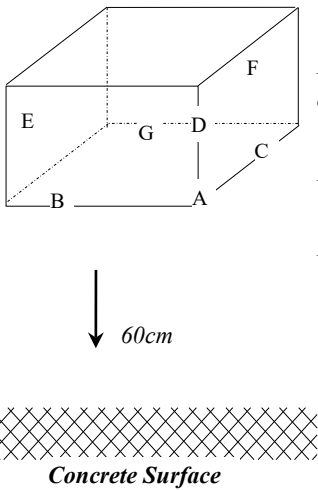
No.	Parameter	Condition	Notes
1	High Temperature Operating	$70^\circ\text{C} \pm 2^\circ\text{C}$, 48hrs (Operation state)	--
2	Low Temperature Operating	$-20^\circ\text{C} \pm 2^\circ\text{C}$, 48hrs (Operation state)	--
3	High Temperature Storage	$80^\circ\text{C} \pm 2^\circ\text{C}$, 48hrs	--
4	Low Temperature Storage	$-30^\circ\text{C} \pm 2^\circ\text{C}$, 48hrs	--
5	High Temperature and High Humidity Operation Test	$60^\circ\text{C} \pm 2^\circ\text{C}$, 90%, 48hrs	--
6	Vibration Test	Total fixed amplitude: 1.5mm Vibration Frequency: 10~55Hz One cycle 60 seconds to 3 direction of X, Y, Z each 15 minutes.	--
7	Drop Test	<p>To be measured after dropping from 60cm high on the concrete surface in packing state.</p>  <p><i>Dropping method corner dropping</i> <i>A corner: once</i> <i>Edge dropping</i> <i>B, C, D edge: once</i> <i>Face dropping</i> <i>E, F, G face: once</i></p>	--

Notes:

1. No dew condensation to be observed.
2. The function test shall be conducted after 4 hours storage at the normal temperature and humidity after removed from the test chamber.
3. Vibration test will be conducted to the product itself without putting it in a container.

10. Quality Inspection Standards

For TFT quality inspection standards, please see the following link: <https://focuslcds.com/tft-quality-inspection-standards/>

11. Cautions and Handling Precautions

11.1 Handling and Operating the Module

1. When the module is assembled, it should be attached to the system firmly. Do not warp or twist the module during assembly work.
2. Protect the module from physical shock or any force. In addition to damage, this may cause improper operation or damage to the module and back-light unit.
3. Note that polarizer is very fragile and could be easily damaged. Do not press or scratch the surface.
4. Do not allow drops of water or chemicals to remain on the display surface. If you have the droplets for a long time, staining and discoloration may occur.
5. If the surface of the polarizer is dirty, clean it using some absorbent cotton or soft cloth.
6. The desirable cleaners are water, IPA (Isopropyl Alcohol) or Hexane. Do not use ketene type materials (ex. Acetone), Ethyl alcohol, Toluene, Ethyl acid or Methyl chloride. It might permanent damage to the polarizer due to chemical reaction.
7. If the liquid crystal material leaks from the panel, it should be kept away from the eyes or mouth. In case of contact with hands, legs, or clothes, it must be washed away thoroughly with soap.
8. Protect the module from static; it may cause damage to the CMOS ICs.
9. Use fingerstalls with soft gloves in order to keep display clean during the incoming inspection and assembly process.
10. Do not disassemble the module.
11. Protection film for polarizer on the module shall be slowly peeled off just before use so that the electrostatic charge can be minimized.
12. Pins of I/F connector shall not be touched directly with bare hands.
13. Do not connect, disconnect the module in the "Power ON" condition.
14. Power supply should always be turned on/off by the item Power On Sequence & Power Off Sequence.

11.2 Storage and Transportation.

1. Do not leave the panel in high temperature, and high humidity for a long time. It is highly recommended to store the module with temperature from 0 to 35 °C and relative humidity of less than 70%
2. Do not store the TFT-LCD module in direct sunlight.
3. The module shall be stored in a dark place. When storing the modules for a long time, be sure to adopt effective measures for protecting the modules from strong ultraviolet radiation, sunlight, or fluorescent light.
4. It is recommended that the modules should be stored under a condition where no condensation is allowed. Formation of dewdrops may cause an abnormal operation or a failure of the module. In particular, the greatest possible care should be taken to prevent any module from being operated where condensation has occurred inside.
5. This panel has its circuitry FPC on the bottom side and should be handled carefully in order not to be stressed.