



FOCUS LCDs

LCDs MADE SIMPLE®

Ph. 480-503-4295 | NOPP@FocusLCDs.com

TFT | OLED | CHARACTER | GRAPHIC | UWVD | SEGMENT | CUSTOM

TFT Display Module

Part Number
E50GB-RW1000-N

Overview:

- 5.0-inch TFT (120.7x75.8 mm)
- 800x480 Pixels
- 24-Bit RGB Interface
- Operating Temp: -20°C to 70°C
- Storage Temp: -30°C to 80°C
- 12:00 Viewing Angle
- Normally White, Transmissive
- No Touch Panel
- Brightness: 1000 Nits
- TFT IC: ILI6126+ILI5960
- RoHS Compliant

Description

This is a color active matrix TFT (Thin Film Transistor) LCD (Liquid Crystal Display) that uses amorphous silicon TFT as a switching device. This model is composed of a transmissive type TFT-LCD Panel, driver circuit, and backlight unit. The resolution of the 5.0" TFT-LCD contains 800x480 pixels.

Features

TFT Interface: 24-bit RGB

Item	Specification	Unit
Screen Size	5.0	Inches
Display Resolution	800RGB(H)x480(V)	Dot
Active Area	108 (H) x 64.8 (V)	mm
Outline Dimension	120.7(W) x 75.8(H) x 2.95 (D)	mm
Display Mode	Normally white/Transmissive	--
Pixel Arrangement	RGB-Vertical Stripe	--
Grayscale Inversion Direction	6 o'clock	
Good Viewing Direction	12 o'clock	--
Drive IC	ILI6122*1 / ILI5960*1	--

Mechanical Information

Item		Min.	Type	Max.	Unit	Note
Module Size	Horizontal (H)	--	120.7	--	mm	--
	Vertical (V)	--	75.8	--	mm	1
	Depth (D)	--	2.95	--	mm	2
Weight		--	TBD	--	g	--

Note (1) Does not include FPC.

Refer to the Outline Dimension for further information.

(2) Back-light units are included.

1. Outline Dimensions

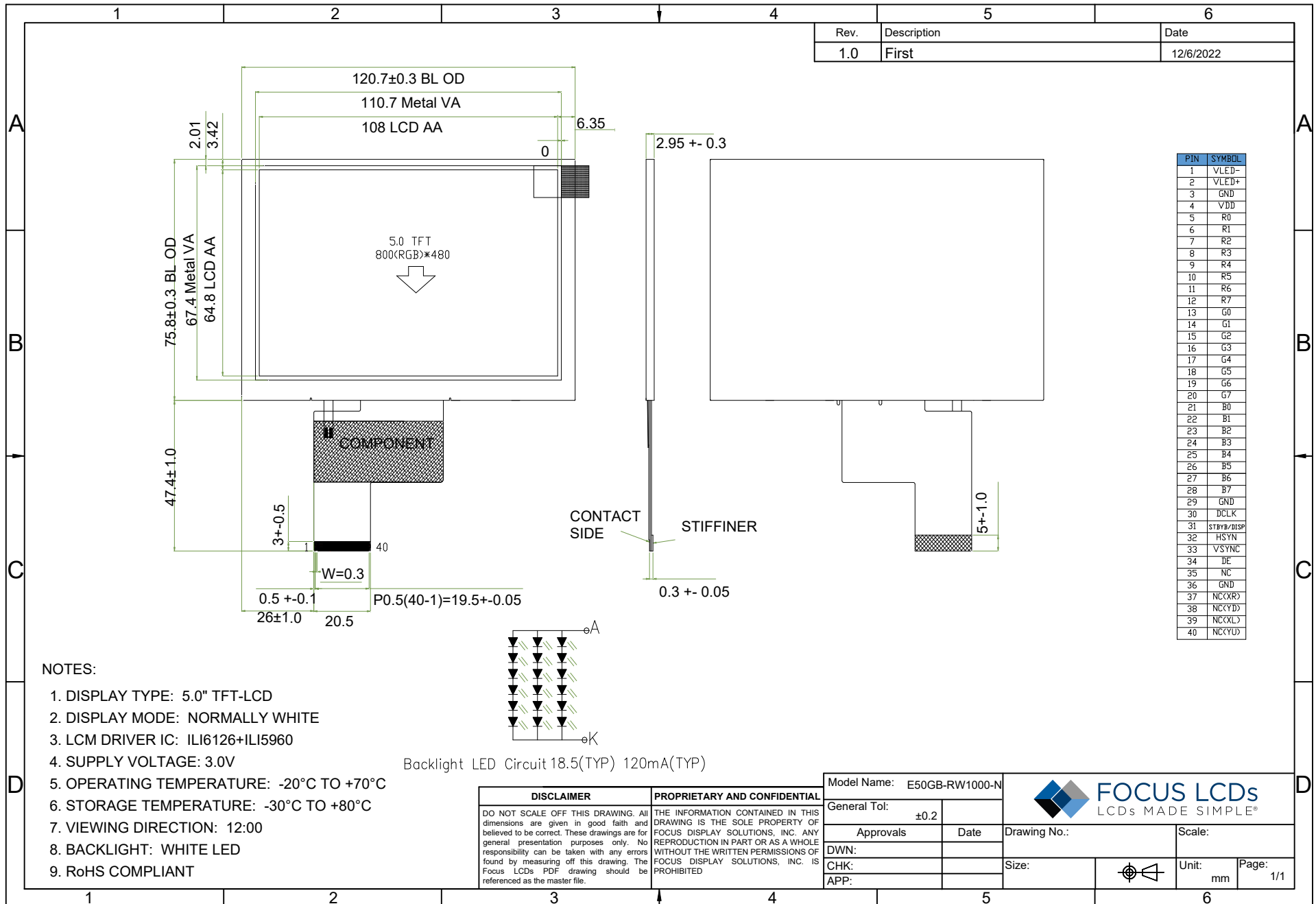

DISCLAIMER	PROPRIETARY AND CONFIDENTIAL
DO NOT SCALE OFF THIS DRAWING. All dimensions are given in good faith and believed to be correct. These drawings are for general presentation purposes only. No responsibility can be taken with any errors found by measuring off this drawing. The Focus LCDs PDF drawing should be referenced as the master file.	THE INFORMATION CONTAINED IN THIS DRAWING IS THE SOLE PROPERTY OF FOCUS DISPLAY SOLUTIONS, INC. ANY REPRODUCTION IN PART OR AS A WHOLE WITHOUT THE WRITTEN PERMISSIONS OF FOCUS DISPLAY SOLUTIONS, INC. IS PROHIBITED

Model Name: E50GB-RW1000-N		 FOCUS LCDs LCDs MADE SIMPLE®	
General Tol: ±0.2			
Approvals	Date	Drawing No.:	Scale:
DWN:		Size:	Unit: mm
CHK:			Page: 1/1
APP:			

2. Input Terminal Pin Assignment

2.1 TFT Pin Assignment

Recommended Connector: FH12S-40S-0.5SH(55)

PIN NO	SYMBOL	I/O	FUNCTION
1	VLED-	P	POWER FOR BACKLIGHT (GROUND)
2	VLED+	P	POWER FOR BACKLIGHT (ANODE)
3	GND	P	GROUND
4	VDD	P	POWER SUPPLY
5-12	R0-R7	I/O	RED DATA
13-20	G0-G7	I/O	GREEN DATA
21-28	B0-B7	I/O	BLUE DATA
29	GND	P	GROUND
30	DCLK	I	DOT CLOCK SIGNAL FOR RGB INTERFACE OPERATION.
31	DISP	I	DISPLAY ON/OFF
32	HSYNC	I	LINE SYNCHRONOUS SIGNAL FOR RGB INTERFACE OPERATION.
33	VSYNC	I	FRAME SYNCHRONOUS SIGNAL FOR RGB INTERFACE OPERATION.
34	DE	I	DATA ENABLE SIGNAL FOR RGB INTERFACE OPERATION.
35	NC	-	NOT CONNECTED
36	GND	P	GROUND
37	XR	-	NOT CONNECTED
38	YD	-	NOT CONNECTED
39	XL	-	NOT CONNECTED
40	YU	-	NOT CONNECTED

3. LCD Optical Characteristics

3.1 Optical Specifications

Item	Symbol	Condition	Min	Type	Max	Unit	Note	
Brightness	B		800	1000	--	cd/m ²	--	
Response time	Tr	$\theta=0^\circ$	-	3	6	ms	--	
	Tf		--	7	14	ms		
Contrast ratio	CR	At optimized viewing angle	300	350	--	--	--	
Luminance Uniformity	ΔL		70	80		%	--	
Color Chromaticity (CIE 1931)	White	Wx	$\theta=0^\circ$ Normal Viewing Angle	0.25	0.30	0.35	--	--
		Wy		0.27	0.32	0.37		
Viewing Angle (6H)	Hor.	θR	CR \geq 10	65	75	--	Degree	--
		θL		65	75	--		
	Ver.	θU		50	60	--		
		θD		60	70	--		

Measuring Conditions:

1. Dark Room
2. Ambient Temperature of 25 \pm 2°C
3. 15 Minute Warm up

Optical Specification Reference Notes:

(1) Definition of Viewing Angle:

The viewing angle is the angle at which the contrast ratio is greater than 10. The viewing angles are determined for the horizontal or 3,9 o'clock direction and the vertical or 6,12 o'clock direction with respect to the optical axis which is normal to the LCD surface.

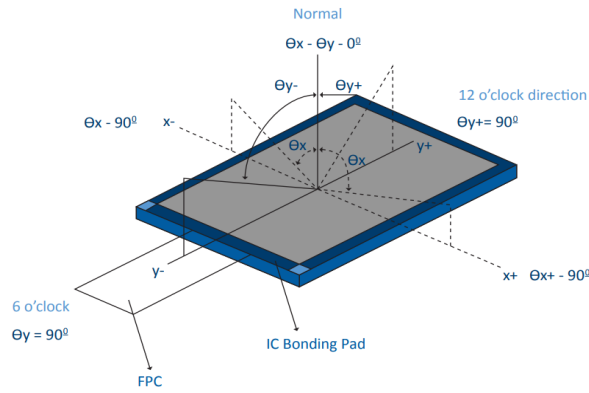

(2) Definition of Contrast Ratio:

Measured at the center point of panel. The contrast ratio (Cr) measured on a module, is the ratio between the luminance (Lw) in a full white area (R=G=B=1) and the luminance (Ld) in a dark area (R=G=B=0).

$$Cr = \frac{Lw}{Ld}$$

(3) Definition of Transmittance (T%):

The transmittance of the panel including the polarizers is measured with electrical driving. The equation for transmittance Tr is:

$$Tr = \frac{I_t}{I_o} \times 100\%$$

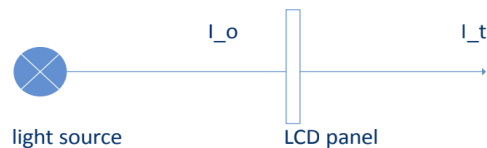

I_o = the brightness of the light source.

I_t = the brightness after panel transmission

(4) Definition of Response Time (TR, TF):

The rise time 'Tr' is defined as the time for luminance to change from 90% to 10% as a result of a change of the electrical condition. The fall time 'Tf' is defined as the time for luminance to change from 10% to 90% as a result of a change of the electrical condition.

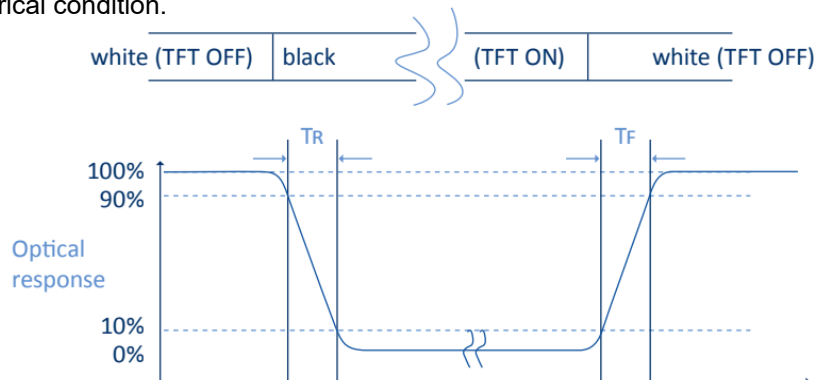

(5) Definition of Color Gamut:

Measuring machine CFT-01. NTSC's Primaries: $R(x,y,Y), G(x,y,Y), B(x,y,Y)$. FPM520 of Westar Display Technologies, INC., which utilized SR-3 for Chromaticity and BM-5A for other optical characteristics. The color chromaticity shall be calculated from the spectral data measured with all pixels first in red, green, blue and white. Measurements shall be made at the center of the panel.

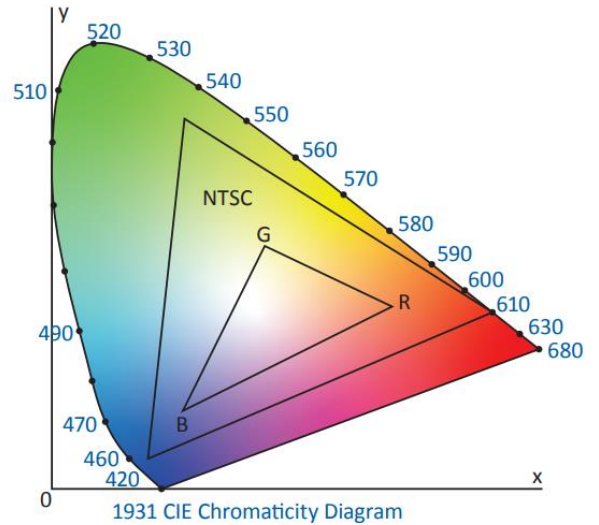
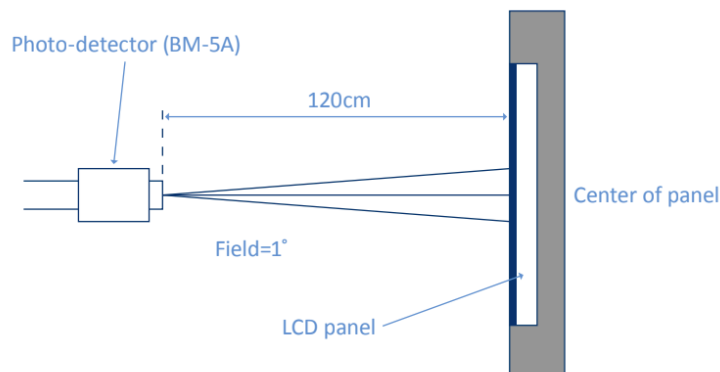
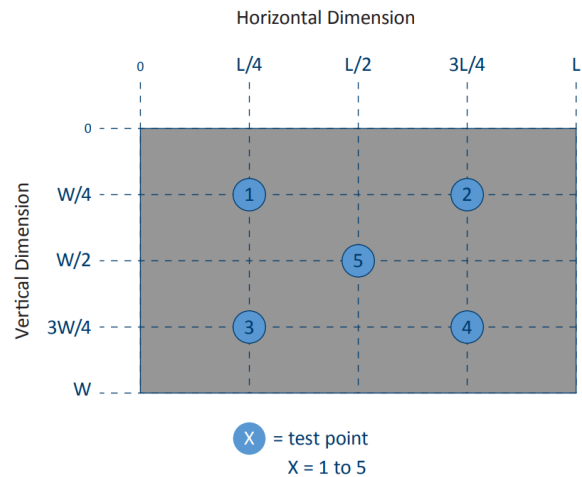
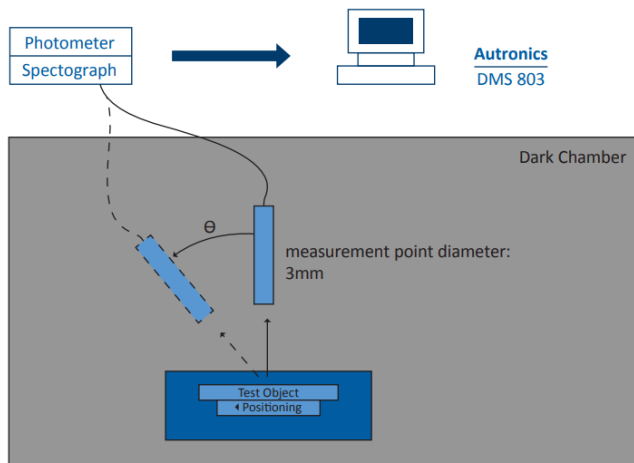

Fig. 1931 CIE chromacity diagram

$$\text{Color gamut: } S = \frac{\text{Area of RGB triangle}}{\text{Area of NTSC triangle}} \times 100\%$$

(6) Definition of Optical Measurement Setup:

The LCD module should be stabilized at a given temperature for 20 minutes to avoid abrupt temperature change during measuring. In order to stabilize the luminance, the measurement should be executed after lighting backlight for 20 minutes.



4. TFT Electrical Characteristics

4.1 Absolute Maximum Rating (Ta=25°C, VSS=0V)

Characteristics	Symbol	Min	Max	Unit
Digital Supply Voltage	VDD	VSS-0.3	5.0	V
Backlight Current (ILED)	If	--	30	mA
Operating Temperature	TOP	-20	+70	°C
Storage Temperature	TST	-30	+80	°C

NOTE: If the absolute maximum rating of the above parameters is exceeded, even momentarily, the quality of the product may be degraded. Absolute maximum ratings specify the values which the product may be physically damaged if exceeded. Be sure to use the product within the range of the absolute maximum ratings.

4.2 Backlight Electrical Characteristics

(Ta=25±2°C)

Characteristics	Symbol	Value			Unit	Condition
		Min.	Typ.	Max.		
LED Voltage	VF	16.2	-	19.8	V	
LED Current	IF	-	120	-	mA	
Power Consumption	P _{BL}	-	-	-	mW	

Note (1) Where $I_F = 60\text{MA}$, $V_F = 16.2\text{-}19.8\text{V}$ $P_{BL} = V_F \times I_F$

4.3 LED Backlight Characteristics

The backlight system is edge lighting type with 18 White LED Chips

Item	Symbol	Min	Typ.	Max	Unit	Note
Forward Current	I_F	--	120	--	mA	--
Forward Voltage	V_F	16.2	--	19.8	V	--
LCM Luminance	L_V	--	1000	--	cd/m ²	(3)
LED Lifetime	H_r	50000	--	--	hour	(1)(2)
Uniformity	Avg	80	--	--	%	(3)

Note 1: LED lifetime (Hr) can be defined as the time in which it continues to operate under the condition: $T_a=25 \pm 3^\circ\text{C}$, typical IL value indicated in the above table until the brightness becomes less than 50%.

Note 2: The "LED lifetime" is defined as the module brightness decrease to 50% original brightness at $T_a=25^\circ\text{C}$ and $IL = 120\text{mA}$. The LED lifetime could be decreased if operating IL is larger than 120mA. The constant current driving method is suggested.

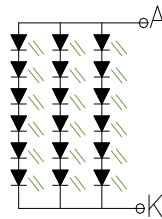

Backlight LED Circuit 18.5(TYP) 120mA(TYP)

Note 3: Luminance Uniformity of these 9 points is defined as below:

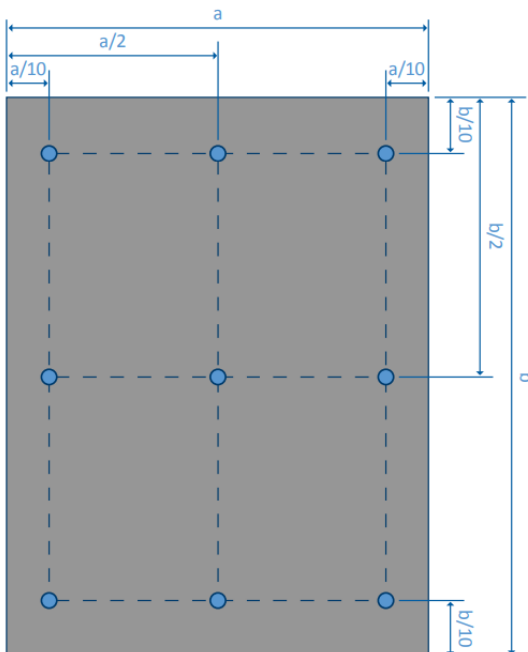

$$\text{Luminance} = \frac{(\text{Total Luminance of 9 Points})}{9}$$

$$\text{Uniformity} = \frac{\text{Minimum Luminance in 9 Points(1-9)}}{\text{Maximum Luminance in 9 Points(1-9)}}$$

5.0 Timing Characteristics

For the timing characteristics table and diagram for this module, please refer to the following driver specifications

- ILI6126
- ILI5960

6.0 Quality Inspection Standards

For TFT quality inspection standards, please see the following link:
<https://focuslcds.com/tft-quality-inspection-standards/>

7.0 Cautions and Handling Precautions

7.1 Handling and Operating the Module

1. When the module is assembled, it should be attached to the system firmly. Do not warp or twist the module during assembly work.
2. Protect the module from physical shock or any force. In addition to damage, this may cause improper operation or damage to the module and back-light unit.
3. Note that polarizer is very fragile and could be easily damaged. Do not press or scratch the surface.
4. Do not allow drops of water or chemicals to remain on the display surface. If you have the droplets for a long time, staining and discoloration may occur.
5. If the surface of the polarizer is dirty, clean it using some absorbent cotton or soft cloth.
6. The desirable cleaners are water, IPA (Isopropyl Alcohol) or Hexane. Do not use ketene type materials (ex. Acetone), Ethyl alcohol, Toluene, Ethyl acid or Methyl chloride. It might permanent damage to the polarizer due to chemical reaction.
7. If the liquid crystal material leaks from the panel, it should be kept away from the eyes or mouth. In case of contact with hands, legs, or clothes, it must be washed away thoroughly with soap.
8. Protect the module from static; it may cause damage to the CMOSICs.
9. Use fingerstalls with soft gloves in order to keep display clean during the incoming inspection and assembly process.
10. Do not disassemble the module.
11. Protection film for polarizer on the module shall be slowly peeled off just before use so that the electrostatic charge can be minimized.
12. Pins of I/F connector shall not be touched directly with bare hands.
13. Do not connect, disconnect the module in the "Power ON" condition.
14. Power supply should always be turned on/off by the item Power On Sequence & Power Off Sequence.

7.2 Storage and Transportation.

1. Do not leave the panel in high temperature, and high humidity for a long time. It is highly recommended to store the module with temperature from 0 to 35 °C and relative humidity of less than 70%
2. Do not store the TFT-LCD module in direct sunlight.
3. The module shall be stored in a dark place. When storing the modules for a long time, be sure to adopt effective measures for protecting the modules from strong ultraviolet radiation, sunlight, or fluorescent light.
4. It is recommended that the modules should be stored under a condition where no condensation is allowed. Formation of dewdrops may cause an abnormal operation or a failure of the module. In particular, the greatest possible care should be taken to prevent any module from being operated where condensation has occurred inside.
5. This panel has its circuitry FPC on the bottom side and should be handled carefully in order not to be stressed.