

APPROVAL SHEET

RF Switch Series – RoHS Compliance

SP4T GPIO Switch

Halogens Free Product

Any 2G/3G/4G Band for TRx System

P/N: RFASWK694CTF09

*Contents in this sheet are subject to change without prior notice.

Approval Sheet

FEATURES

- Low Insertion Loss and Low Distortion
- Broadband frequency range : 0.5 to 2.7 GHz
- Low ON-state resistance and OFF-state capacitance
- High power and peak voltage handling
- Low control voltage : 1.3V to 2.7V
- High ESD tolerance of 2kV HBM at all pins
- Miniature footprint : 1.1 x 1.5 x 0.45 mm³ (QFN 10-Pin)
- Moisture Sensitive Level 3 (MSL3)

Description

- The RFASWK694CTF09 is a Single-Pole, Four-Throw (SP4T) switch designed for antenna tuning applications that require very low R_{ON} and C_{OFF} . The RFASWK694CTF09 provides rugged power handling and simple 2-bit GPIO control.
- The RFASWK694CTF09 features very low DC power consumption.

Application

- Antenna Tuning
- Band Switching
- Impedance Tuning

Block Diagram and Pin Out (Top View)

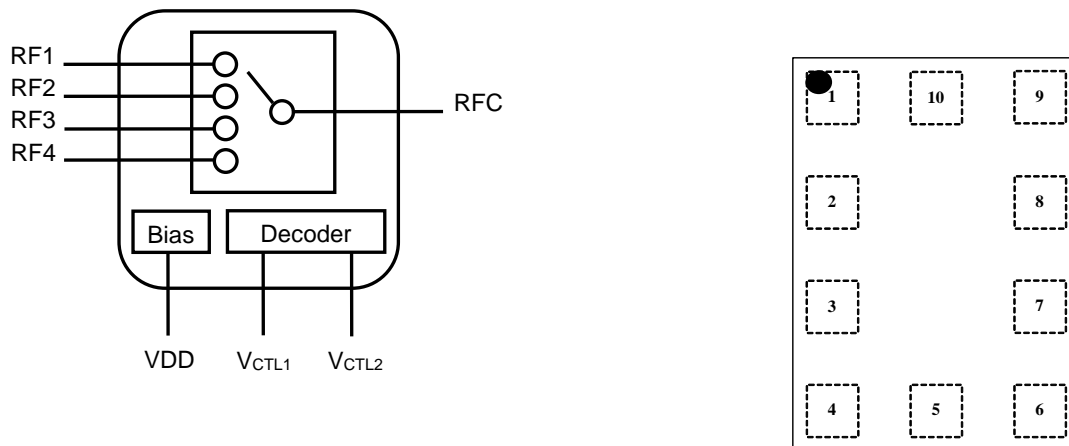

Pin Names and Descriptions

Pin	Name	Description	Pin	Name	Description
1	RF1	RF path 1	6	V _{CTL2}	DC control voltage 2
2	RF2	RF path 2	7	GND	Ground
3	GND	Ground	8	RF4	RF path 4
4	VDD	DC power supply	9	RF3	RF path 3
5	V _{CTL1}	DC control voltage 1	10	RFC	RF common port

Approval Sheet

Application Circuit

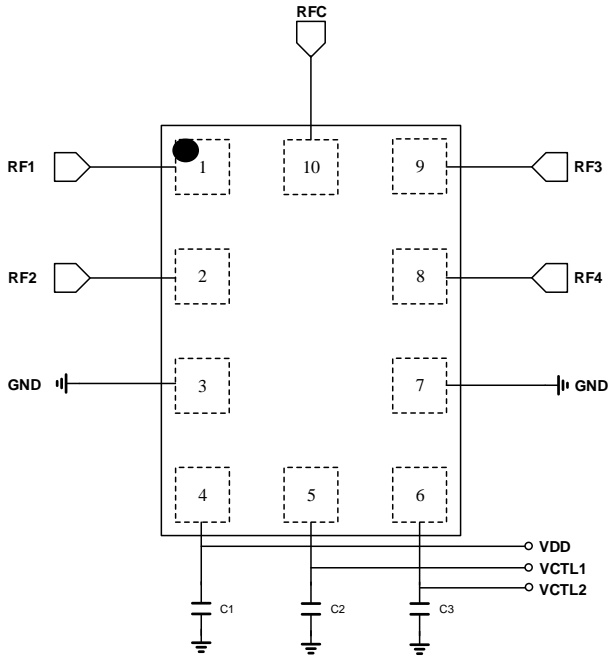

Parts List

Parts No.	Value
C1~C3	0.1uF

Absolute Maximum Ratings

Parameter	Symbol	Minimum	Maximum	Units
RFx Input Power, 50Ω	P _{in}		+40	dBm
DC Supply Voltage	V _{DD}		+5.0	V
DC Control Voltage	V _{CTL}		+3.3	V
Max differential RF voltage between the RF ports V _{RF}	V _P		32	V
Storage temperature	T _{STG}	-55	+150	°C
Operating temperature	T _{OP}	-40	+85	°C
HBM ESD Voltage, All Pins	V _{ESD} ¹	-	+2000	V

Note 1 : Human Body Model ESD Voltage

Exceeding absolute maximum ratings may cause permanent damage. Operation between operating range maximum and absolute maximum for extended periods may reduce reliability.

Approval Sheet

Electrical Specifications

(Top= 25°C, VDD=2.85V, V_{CTL}=0/1.8V, Characteristic Impedance Z₀= 50 Ω, Unless Otherwise Noted)

Parameter	Symbol	Test Condition	Min.	Typ.	Max.	Units
RF Specifications						
Operating Frequency	f		500		2700	MHz
Insertion Loss (RFC to RFx port)	IL	615 ~700 MHz 700 ~915 MHz 915 ~1910 MHz 1910~2700 MHz		0.30 0.38 0.58 0.67	0.35 0.48 0.75 1.00	dB dB dB
Isolation (RFC to RFx port)	Iso	615 ~700 MHz 700 ~915 MHz 915 ~1910 MHz 1910~2700 MHz	22 20 18 16	24 22 20 18		dB dB dB
Return Loss (RFC) Logic States 1, 2, 3, 4	VSWR	700 MHz 915 MHz 1910 MHz		1.29 1.43 1.58	1.50 1.58 1.78	
RFx Harmonics	2 _{f₀}	PIN = +23dBm, f = 700MHz PIN = +35dBm, f = 915MHz PIN = +33dBm, f = 1910MHz PIN = +23dBm, f = 2570MHz		-82 -60 -60 -70		dBm dBm dBm dBm
	3 _{f₀}	PIN = +23dBm, f = 700MHz PIN = +35dBm, f = 915MHz PIN = +33dBm, f = 1910MHz PIN = +23dBm, f = 2570MHz		-98 -60 -70 -85		dBm dBm dBm dBm
2nd Order Input Intercept Point	IIP2	See IIP2 test conditions Table		120		dBm
3rd Order Input Intercept Point	IIP3	See IIP3 test conditions Table		75		dBm
RON (RFC to RF1/RF2/RF3/RF4) Logic States 1, 2, 3, 4	R _{ON}			1.2		Ω
COFF (RFC to RF1/RF2/RF3/RF4) Logic States 1, 2, 3, 4	C _{OFF}			0.15		pF
DC Specification (Decoder)						
Supply Voltage	V _{DD}		2.5	2.85	4.5	V
Supply Current	I _{DD}			55		μA
Control Voltage(High)	V _{CTL(H)}		1.3	1.8	2.7	V
Control Voltage(Low)	V _{CTL(L)}		0	0	0.45	V
Control Current	I _{CTL}	V _{CTL} = 1.8V		2		μA
Switching Specification						
Start-up time	T _{ON}	50% VDD to large signal fully compliant		10		μs
On switching speed	T _{SW}	50% V _{CTL} to 90% RF On		5		μs
Off switching speed	T _{SW}	50% V _{CTL} to 90% RF Off		5		μs

Note : All measurements are made in a 50Ω system with 0/+1.8V control voltages, unless otherwise specified.

Approval Sheet

IIP2 Test Conditions

Band	In-Band Freq (MHz)	CW tone 1 (MHz)	CW tone 1 (dBm)	CW tone 2 (MHz)	CW tone 2 (dBm)
1	2140.0	1950.0	+20	190.0	-15
			+26	4090.0	-20
2	1960.0	1880.0	+20	80.0	-15
			+26	3840.0	-20
5	881.5	836.5	+20	45.0	-15
			+26	1718.0	-20
8	942.5	897.5	+20	45.0	-15
			+26	1840.0	-20

IIP3 Test Conditions

Band	In-Band Freq (MHz)	CW tone 1 (MHz)	CW tone 1 (dBm)	CW tone 2 (MHz)	CW tone 2 (dBm)
1	2140.0	1950.0	+20	1760.0	-15
2	1960.0	1880.0	+20	1800.0	-15
5	881.5	836.5	+20	791.5	-15
8	942.5	897.5	+20	852.5	-15

Logic Table for Switch On-Path (High=1.8V ,Low= 0V)

V _{CTL1}	V _{CTL2}	RF1	RF2	RF3	RF4
0	0	on	off	off	off
0	1	off	on	off	off
1	0	off	off	on	off
1	1	off	off	off	on
X	X	Low Power Mode			

Approval Sheet

Package Dimensions

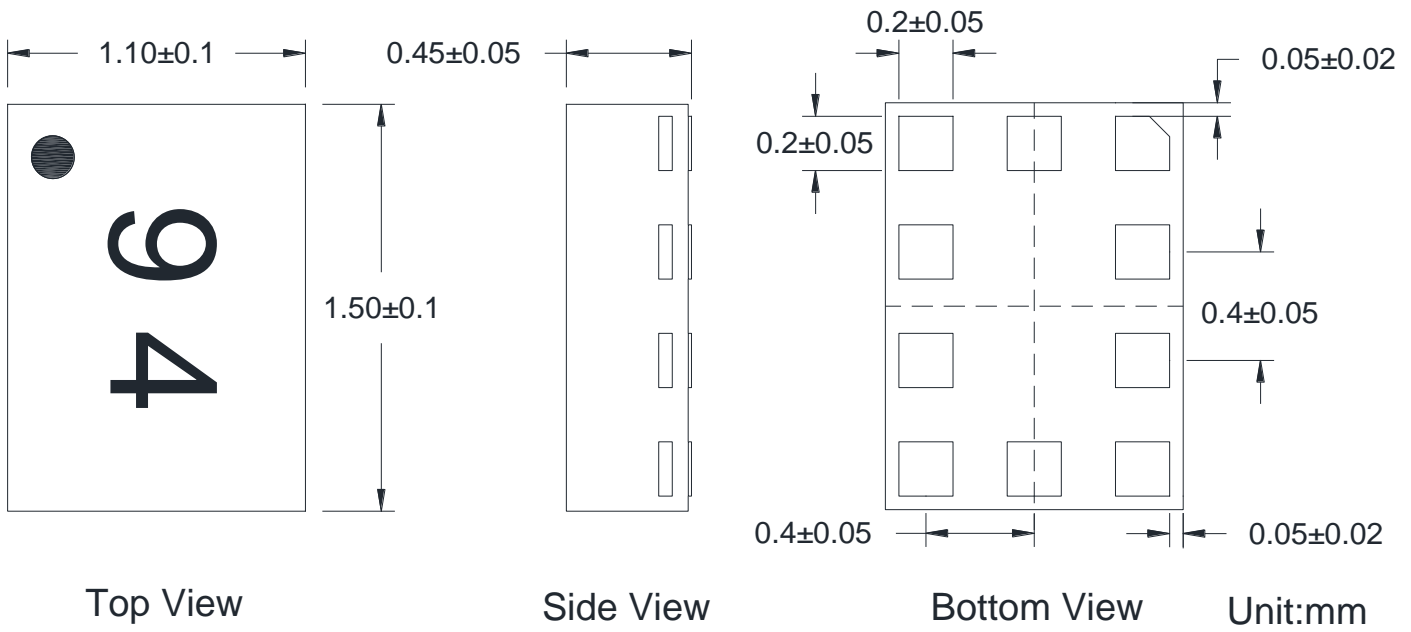

Land Pattern

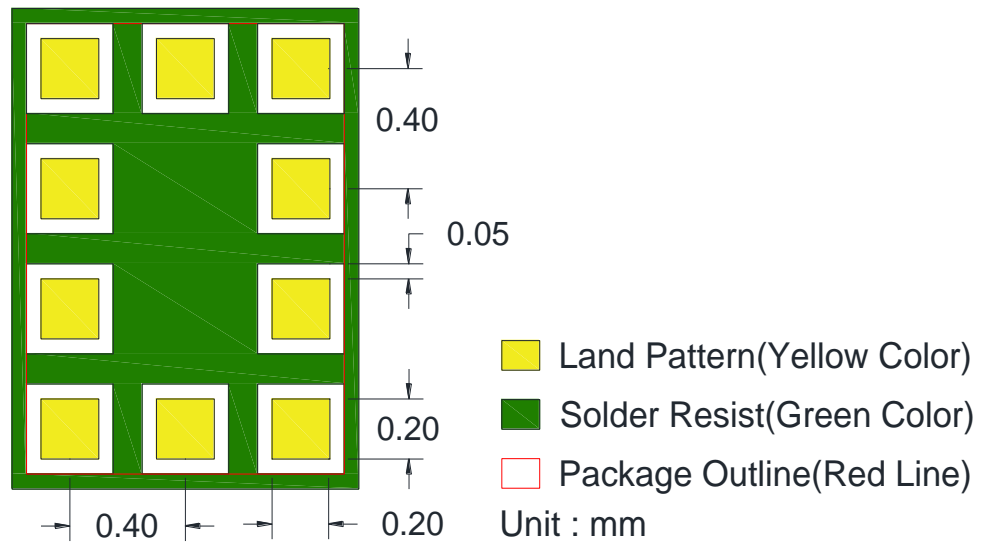

Approval Sheet

Reliability test

TEST	PROCEDURE / TEST METHOD	REQUIREMENT
Solderability JIS C 0050-4.6 JESD22-B102D	*Solder bath temperature : $255 \pm 5^{\circ}\text{C}$ *Immersion time : 5 ± 0.5 sec Solder : Sn3Ag0.5Cu for lead-free	At least 95% of a surface of each terminal electrode must be covered by fresh solder.
High temperature JIS C 0021	*Temperature : $90^{\circ}\text{C} \pm 2^{\circ}\text{C}$ *Test duration : $1000+24/-0$ hours Measurement to be made after keeping at room temperature for 24 ± 2 hrs	No mechanical damage. Electrical specification shall satisfy the descriptions in electrical characteristics under the operational temperature range within $-30 \sim 90^{\circ}\text{C}$.
Low temperature JIS C 0020	*Temperature : $-30^{\circ}\text{C} \pm 2^{\circ}\text{C}$ *Test duration : $1000+24/-0$ hours Measurement to be made after keeping at room temperature for 24 ± 2 hrs	No mechanical damage. Electrical specification shall satisfy the descriptions in electrical characteristics under the operational temperature range within $-30 \sim 90^{\circ}\text{C}$.
Temperature cycle JIS C 0025	1. 30 ± 3 minutes at $-30 \pm 3^{\circ}\text{C}$, 2. 10~15 minutes at room temperature, 3. 30 ± 3 minutes at $+90 \pm 3^{\circ}\text{C}$, 4. 10~15 minutes at room temperature, Total 100 continuous cycles Measurement to be made after keeping at room temperature for 24 ± 2 hrs	No mechanical damage. Electrical specification shall satisfy the descriptions in electrical characteristics under the operational temperature range within $-30 \sim 90^{\circ}\text{C}$.
High temperature operation life (HTOL)	*Temperature : 90°C *V = Vmax *Time : $1000+24/-0$ hrs. Measurement to be made after keeping at room temperature for 24 ± 2 hrs	No mechanical damage. Electrical specification shall satisfy the descriptions in electrical characteristics under the operational temperature range within $-30 \sim 90^{\circ}\text{C}$.

Soldering condition

Typical examples of soldering processes that provide reliable joints without any damage are given in Figure 11.

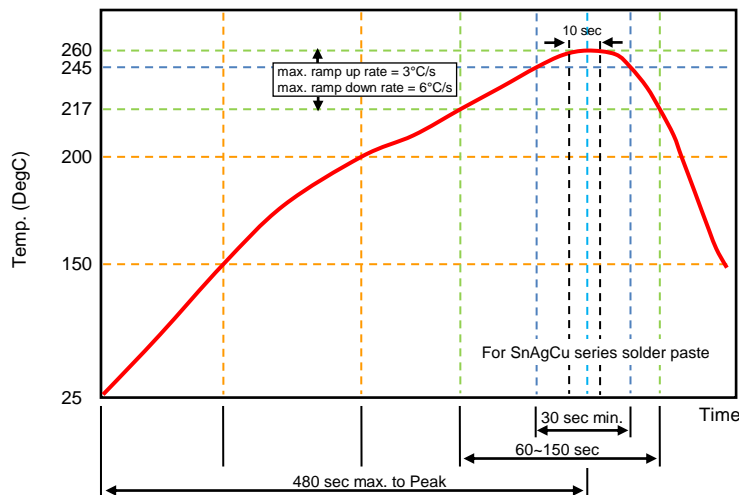

Figure 11. Infrared soldering profile

Approval Sheet

Ordering code

RF	ASW	K	694C	T
RF module RF: Walsin RF Switch Device	Module type ASW: Antenna Switch	Application K: SP4T	Design Code	Packing T: Taping

Minimum Ordering Quantity: 3000 pcs per reel.

Packaging

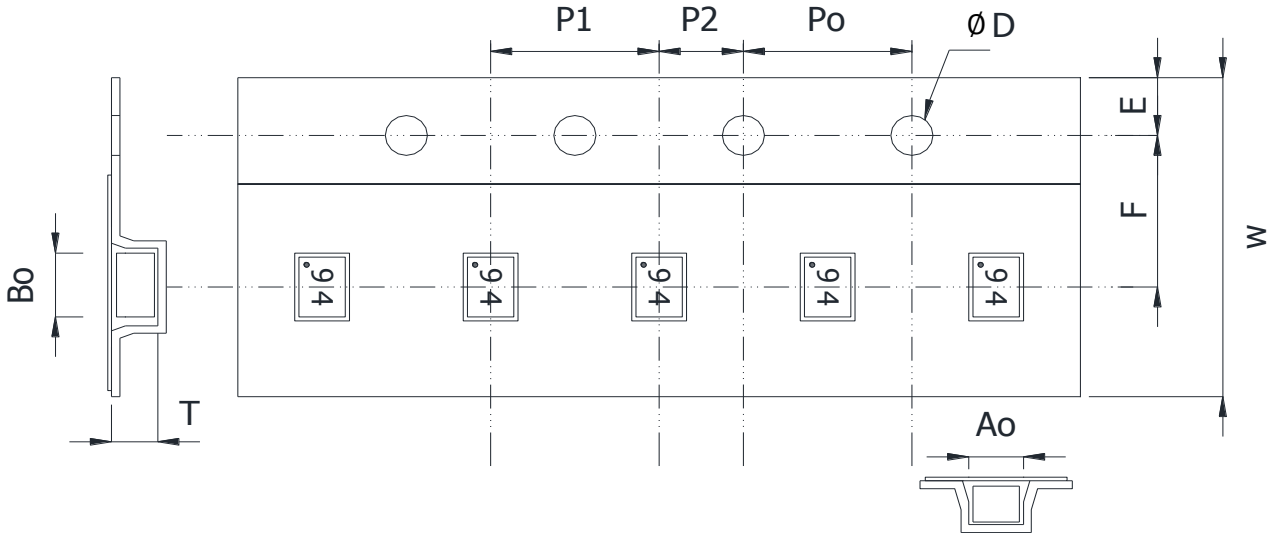

Plastic Tape specifications (unit :mm)

Index	Ao	Bo	ΦD	T	W
Dimension (mm)	1.30 ± 0.05	1.70 ± 0.05	1.55 ± 0.05	0.60 ± 0.05	8.0 ± 0.20
Index	E	F	Po	P1	P2
Dimension (mm)	1.75 ± 0.10	3.50 ± 0.05	4.00 ± 0.05	4.00 ± 0.05	2.00 ± 0.05

Reel dimensions

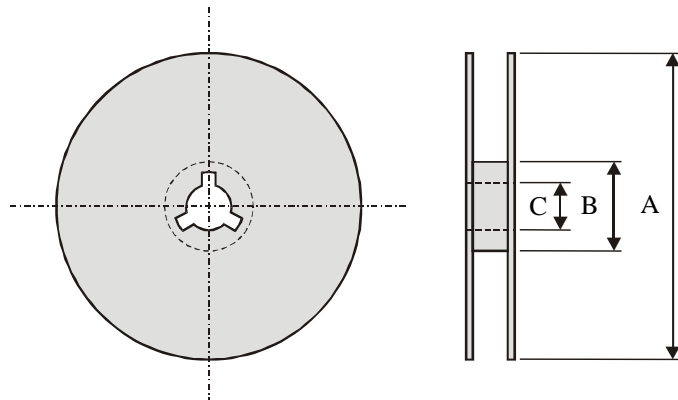

Index	A	B	C
Dimension (mm)	Φ178.0	Φ54.0	Φ13.2

Taping Quantity : 3000 pieces per 7" reel

Approval Sheet

Caution of handling

Limitation of Applications

Please contact us before using our products for the applications listed below which require especially high reliability for the prevention of defects, which might directly cause damage to the third party's life, body or property.

- (1) Aircraft equipment
- (2) Aerospace equipment
- (3) Undersea equipment
- (4) Medical equipment
- (5) Disaster prevention / crime prevention equipment
- (6) Traffic signal equipment
- (7) Transportation equipment (vehicles, trains, ships, etc.)
- (8) Applications of similar complexity and /or reliability requirements to the applications listed in the above.

Storage condition

- (1) Products should be used in 6 months from the day of WALSIN outgoing inspection, which can be confirmed.
- (2) Storage environment condition.
 - Products should be storage in the warehouse on the following conditions.
 - Temperature : -10 to +40°C
 - Humidity : 30 to 70% relative humidity
 - Don't keep products in corrosive gases such as sulfur. Chlorine gas or acid or it may cause oxidization of electrode, resulting in poor solderability.
 - Products should be storage on the palette for the prevention of the influence from humidity, dust and son on.
 - Products should be storage in the warehouse without heat shock, vibration, direct sunlight and so on.
 - Products should be storage under the airtight packaged condition.