



Shenzhen Yajingxin Electron Co.,Ltd

Customer	
Production Name	SMD CRYSTAL SEAM 3.2*2.5
Customer P/N	N/A
P/N	T322532768MLBDE2X
Revision	A
Print Date	2024-02-22

Drawn	Checked	Approved
		



RoHS Compliant



Shenzhen Yajingxin Electron Co.,Ltd

● ELECTRICAL PARAMETERS

谐振器产品技术指标		Min	Max	Units
1. Holder Type(型号规格)		SEAM 3.2*2.5		
2. Mode of Oscillation (振动模式)		Fundamental		
3. Frequency (标称频率)		32.768000		MHz
4. Load Capacitance (CL) (负载电容)		20		pF
5. Drive Level (激励功率)		≤100		uw
6. Equivalent Resistance (谐振电阻)		≤30		Ω
7. Shunt Capacitance (Co) (静态电容)		0	3	pF
8. Motional Capacitance (C1) (动态电容)		N/A		fF
9. Frequency Tolerance at 25°C (调整频差)		-10	10	ppm
10. Stability over operation temperature (温度频差)		±30 基准温度: 25°C		ppm
11. Insulation Resistance (at DC 100V) (绝缘电阻)		500MΩ Min @100V		MΩ
12. Operating Temperature Range (工作温度范围)		-30	85	°C
13. Storage Temperature Range (储存温度范围)		-45	85	°C
14. Aging (老化率)		±3		ppm/year
15. DLD2	N/A		N/A	Ω
16. FLD2			N/A	ppm
17. RLD2			N/A	Ω
18. SPDB			N/A	db
19. Other(其它)		N/A		

OUTLINE DIMENSIONS(UNIT:mm) 外形尺寸 (单位: mm)

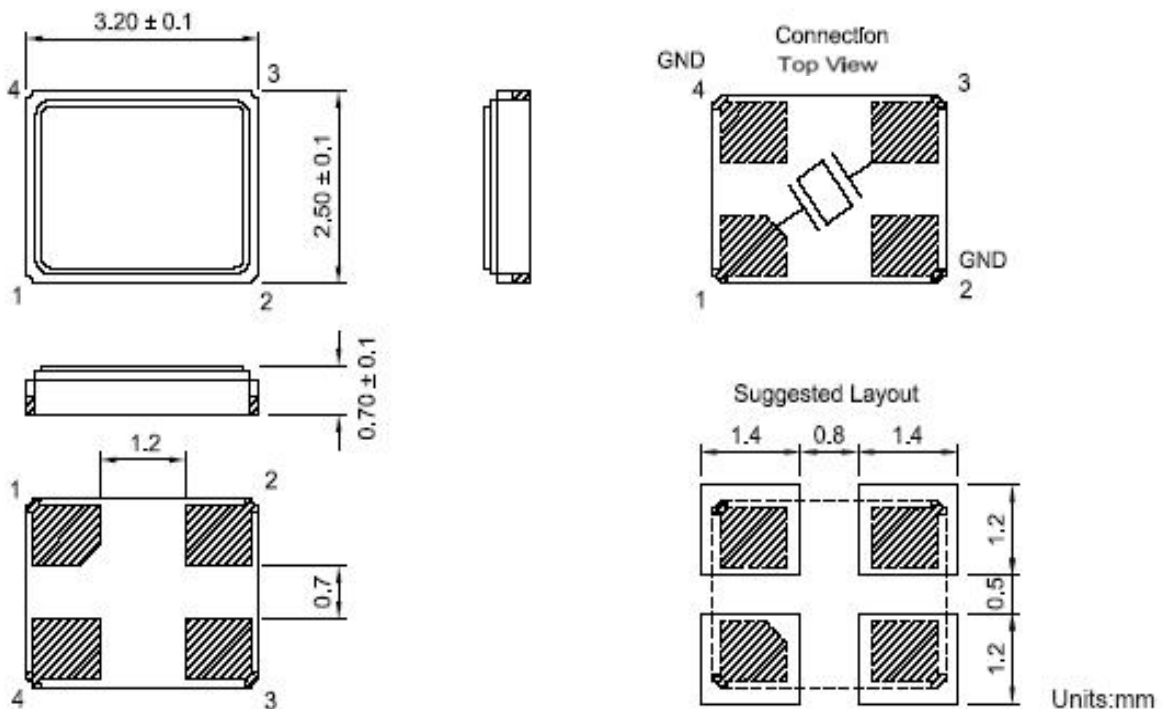



Shenzhen Yajingxin Electron Co.,Ltd

● SUGGESTED REFLOW PROFILE (回流焊曲线图)

Total time:200sec.Max. (总时间: 200秒 最大)

Solder melting point:220℃ (熔点220℃)

Profiles Feature (特性)		Pb-Free Assembly
Average Ramp-up Rate(Ts max to Tp) 平均升温速度		3℃/second Max
Preheat 预热		
■ Temperature Min (Ts min) 最低温度		125℃
■ Temperature Max (Ts max) 最高温度		200℃
■ Time (ts min to ts max) 从最低到最高时间		(60~180) seconds
Time maintained above 维持上述时间		
■ Temperature(T1) 温度		217℃
■ Time(tp) 时间		(60~150) seconds
Peak/Classification Temperature(Tp) 最高点温度		260℃
Time within 5℃ of actual Peak Temperature(tp) 高温维持时间		(20~40) seconds
Ramp-down rate 降温速度		6℃/second max
Time 25℃ to Peak Temperature 从25℃到最高温度的时间		8 minutes max
Suggest reflow times 建议 reflow次数		3 Times max

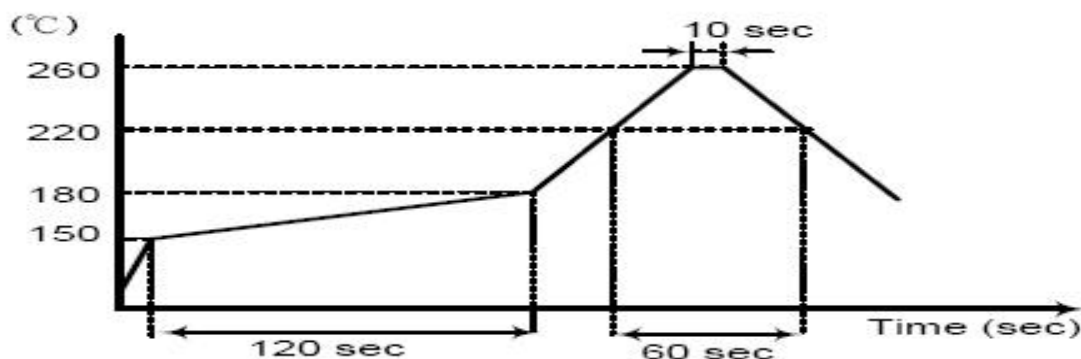

★ 备注:

1. 以上可靠性项目为我司常规测试项目, 若客户对产品有跌落, 冲击, 碰撞以及涉及到超声波焊接工艺的需求, 请将贵司的需求反馈给我司, 我司会对该产品的可靠性项目进行更新。
2. 客户端在对晶体加热后, 为了保证频率的准确性, 建议将晶体充分冷却后再进行相关测试。
3. 产品符合环保标准要求, 如需测试报告请联系我们提供。

● PACKING (包装) 3Kpcs/REEL

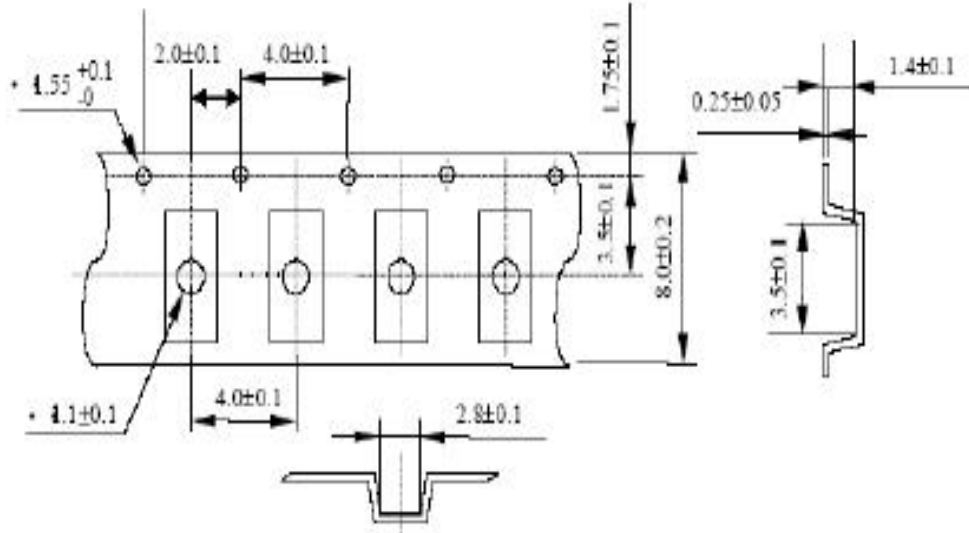

[Size in mm]

8.3. Reel dimension & Outline drawing

Material of the Reel : PS

