

GENERAL DESCRIPTION

This user's guide explains how to quickly obtain the push-pull converter performance results with the MX6501T evaluation module (EVM). This EVM provides three push-pull converters for various input-to-output voltage conversions. All push-pull converters use low-power, center-tapped transformers from Maxin Micro whose designs have been optimized in form-factor, turns ratio, and saturation product to operate in combination with the MX6501T transformer driver. The following table lists the push-pull converter configurations with their associated transformers.

这为用户手册能够帮助迅速的了解无锡明芯微电子的推挽驱动 MX6501 和其对应的变压器实现的隔离效果和隔离效率 无锡明芯微的 MX6501 采用内置 36VLD MOS 的工艺 0.2 欧姆的内阻, 配合提供的不同变压器, 能够实现 12V 转 12V 输出, 5V 转 12V 输出和 5V 转 5V 以及 3.3V 转 3.3V 等不同的隔离输出, 该几款组合采用的是无 LDO 的方案, 由于是开路无反馈在输出端加了一个假负载 13kohm 能够实现 10% 以内的电压误差变动, 客户也可以加 LDO, 如果客户想实现小的低功耗可以选用 MX6505T 的产品, MX6505T 的产品有使能控制脚, 如果不用可以让该推挽输出停止工作达到节能目的

PNs	VIN: VOUT	Transformer	Turns Ratio	V-T(Vus)	隔离
MX6501T 5V-5V EVM	5V 转 5V 最大 0.6A 输出	MXPP6-3K6110	1:1.10	11	3kv
MX6501T 12V-12V EVM	12V 转 12V 最大 0.6A 输出	MXPP8-30-1103	1:1.03	30	3kv
NA	5V:12V 最大 0.3A 输出	MXPP8-30-1250	1:2.50	10	3kv

Schematic and Board Layout

The following figure shows the Schematic of the EVM board.

下面是 5V 转 5V 的评估电路板线路图 采用的是 MX6501T+MXPP6-3K110 组合

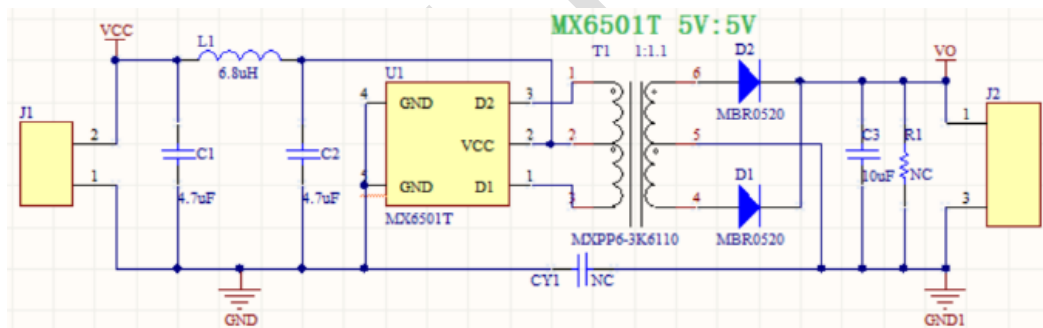

MX6501T 5V:5V EVM Schematic

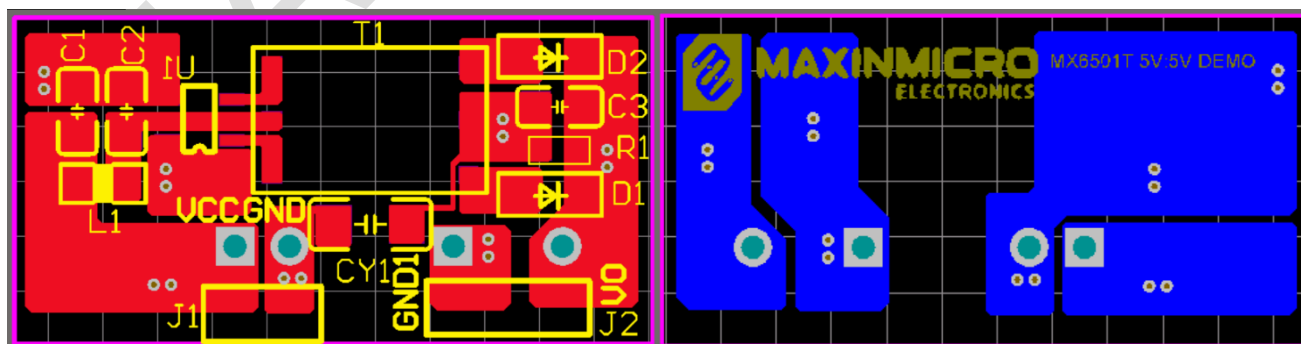

MX6501T 5V:5V EVM PCB Top Layer and Bottom Layer

下面是 MX6501T+MXPP8-30-1103 组合实现的是最大 12V 转 12V0.5A 的输出功率，效率如下图

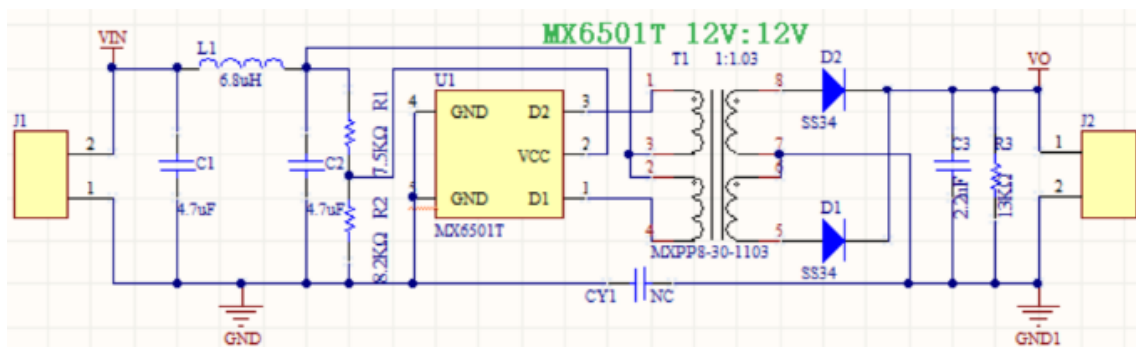

MX6501T 12V:12V EVM Schematic

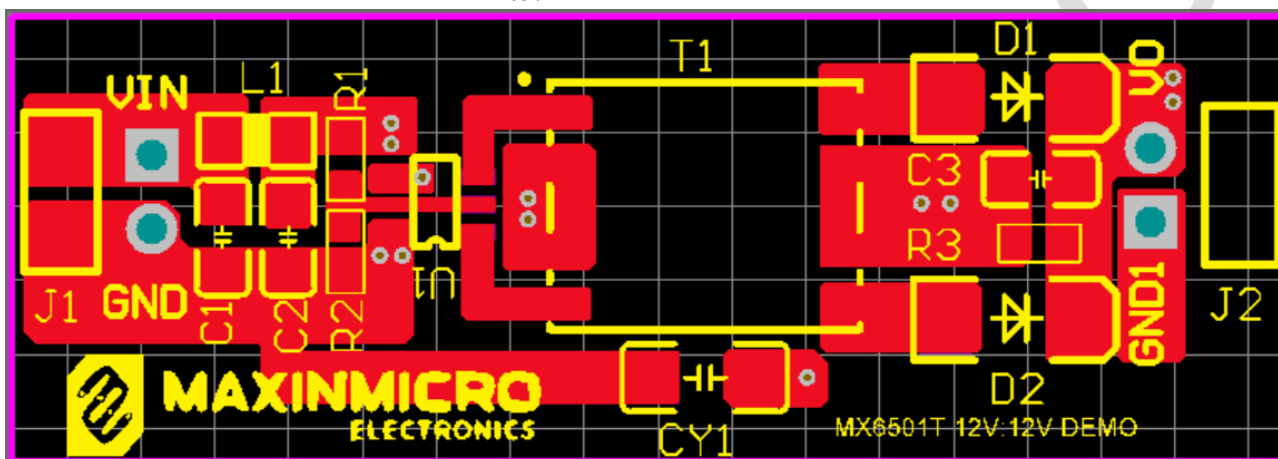

MX6501T 12V:12V EVM PCB Top Layer

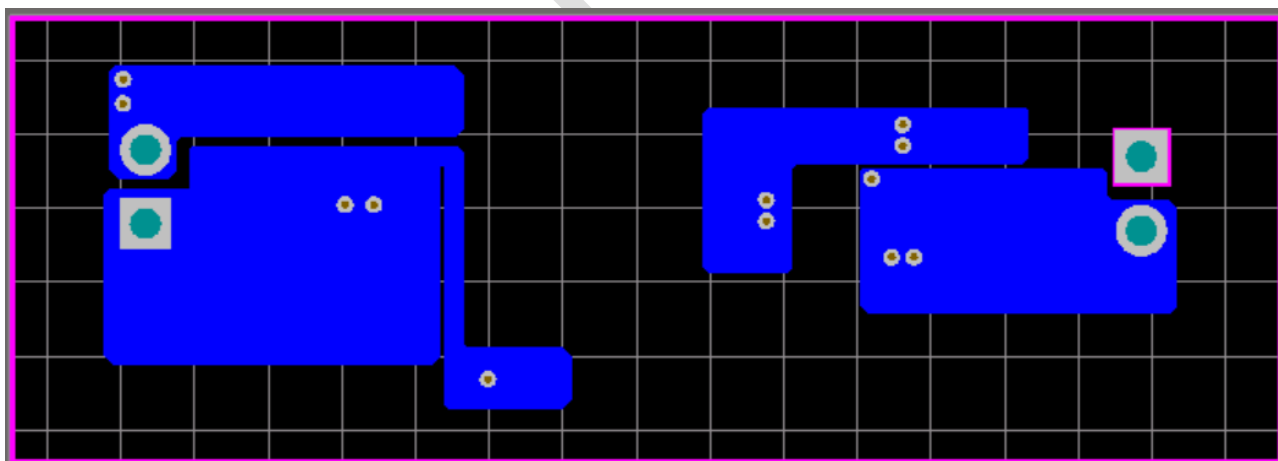

MX6501T 12V:12V EVM PCB Bottom Layer

如下是 MX6051T+MXPP8-30-1250 组合实现的是 5V 转 12V 最大 0.3A 的输出功率

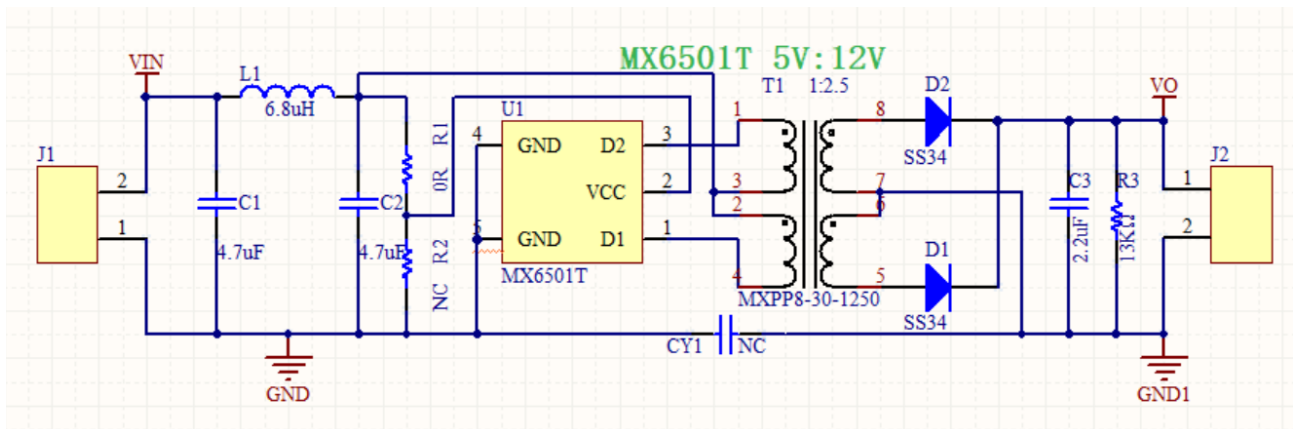

MX6501T 5V:12V EVM Schematic

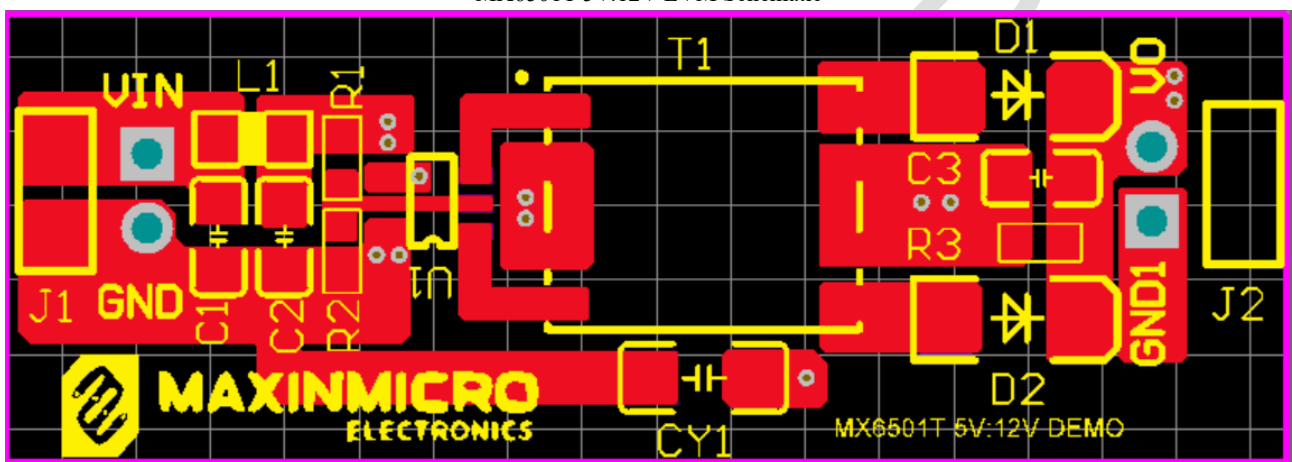

MX6501T 5V:12V EVM PCB Top Layer

Bill of Materials

The following table lists the bill of materials for the MX6501T-5V:5V DEMO.

serial number	Comment	Designator	Footprint	Quantity	Manufacturer
1	4.7uF/25V	C1, C2	C-0805	2	
2	10uF/25V	C3	C-0805	1	
3	NC	CY1	C-1206	1	
4	MBR0520	D1, D2	D-SOD-123	2	
5	2.54mm 2pin Header	J1	HDR-TH_2P-P2.54-H-M-W10.4	1	
6	2.54mm3pin Header	J2	HDR-TH_3P-P2.54-H-M-W10.4	1	
7	6.8uH	L1	R-0805	1	
8	NC	R1	R-0603	1	
9	MXPP6-3K6110	T1	变压器 10.05*6.73mm	1	MAXIN MICRO
10	MX6501T	U1	SOT23-6	1	MAXIN MICRO

The following table lists the bill of materials for the MX6501T-12V:12V DEMO.

serial number	Comment	Designator	Footprint	Quantity	Manufacturer
1	4.7uF/25V	C1, C2	C-0805	2	
2	2.2uF/50V	C3	C-0805	1	
3	NC	CY1	C-1206	1	
4	SS34	D1, D2	D-SMA	2	
5	NC	J1, J2	HDR-TH_2P-P2.54-H-M-W10.4	2	
6	6.8uH	L1	R-0805	1	
7	7.5KΩ	R1	R-0603	1	
8	8.2KΩ	R2	R-0603	1	
9	13KΩ	R3	R-0603	1	
10	MXPP8-30-1103	T1	变压器-SMD	1	MAXIN MICRO
11	MX6501T	U1	SOT23-6	1	MAXIN MICRO

The following table lists the bill of materials for the MX6501T-5V:12V DEMO.

serial number	Comment	Designator	Footprint	Quantity	Manufacturer
1	4.7uF/25V	C1, C2	C-0805	2	
2	2.2uF/50V	C3	C-0805	1	
3	NC	CY1	C-1206	1	
4	SS34	D1, D2	D-SMA	2	
5	NC	J1, J2	HDR-TH_2P-P2.54-H-M-W10.4	2	
6	6.8uH	L1	R-0805	1	
7	0Ω	R1	R-0603	1	
8	NC	R2	R-0603	1	
9	13KΩ	R3	R-0603	1	
10	MXPP8-30-1250	T1	变压器-SMD	1	MAXIN MICRO
11	MX6501T	U1	SOT23-6	1	MAXIN MICRO

Efficiency test data/效率数据搞到 90%

MX6501T 5V:5V efficiency														
IO(mA)	0	10	20	30	40	50	60	70	80	90	100	200	300	400
η(%)	0	60.84	73.09	78.45	81.29	83.83	84.8	85.4	85.97	86.18	86.82	87.27	84.91	84.28
MX6501T 12V:12V efficiency														
IO(mA)	0	10	20	30	40	50	60	70	80	90	100	200	300	400
η(%)	0	62.86	75.41	81.2	84.35	86.88	87.94	89.29	89.41	89.71	91.27	92.06	88.67	88.02

MX6501T 5V:12V efficiency																			
IO(mA)	0	10	20	30	40	50	60	70	80	90	100	110	120	130	140	150	200	250	300
η(%)	0.00	50.22	65.44	73.43	77.80	80.56	82.30	83.71	85.68	86.47	86.86	87.10	87.12	87.23	87.24	86.38	86.20	83.85	81.33

Characteristic plots and waveforms

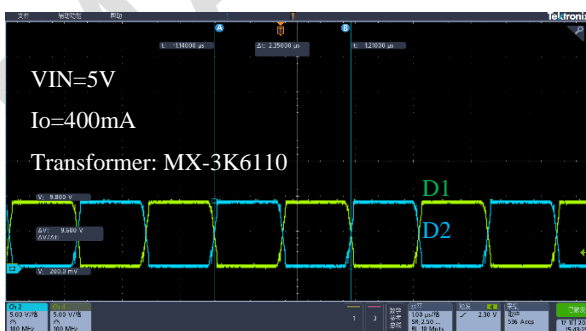
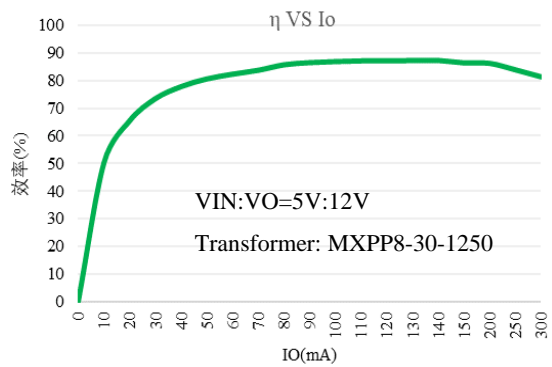
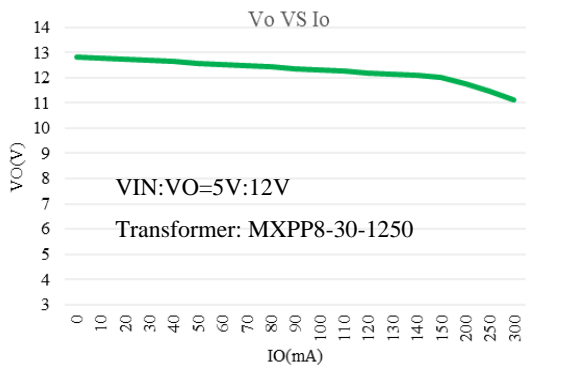
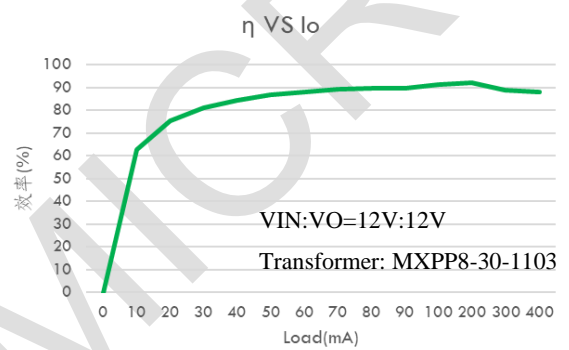
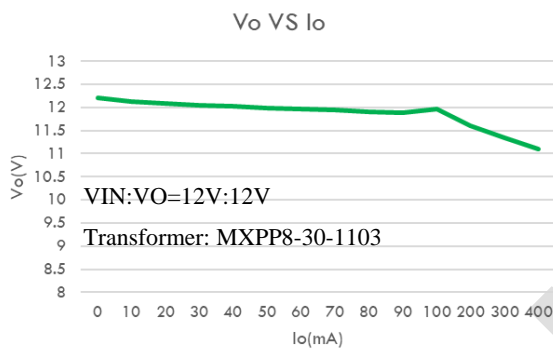
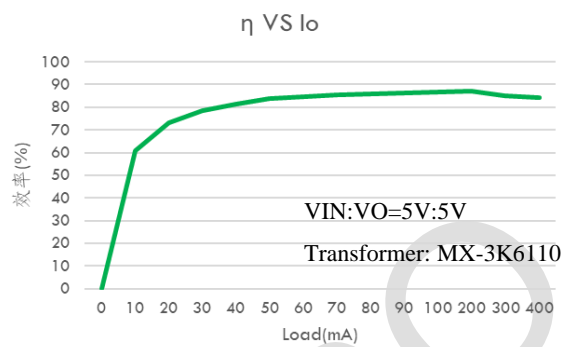
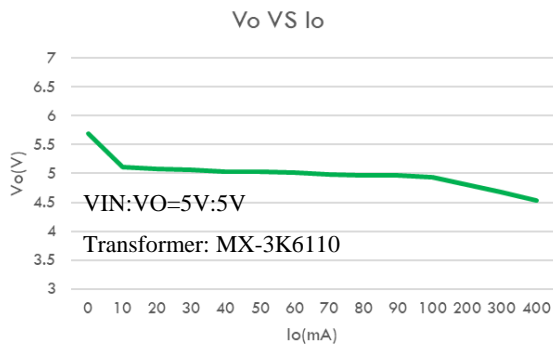

D1, D2 with Normal operation

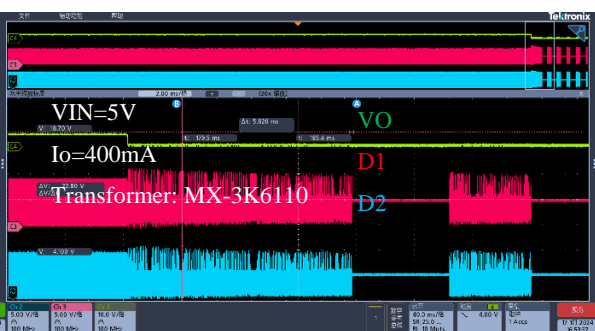

Output short protection

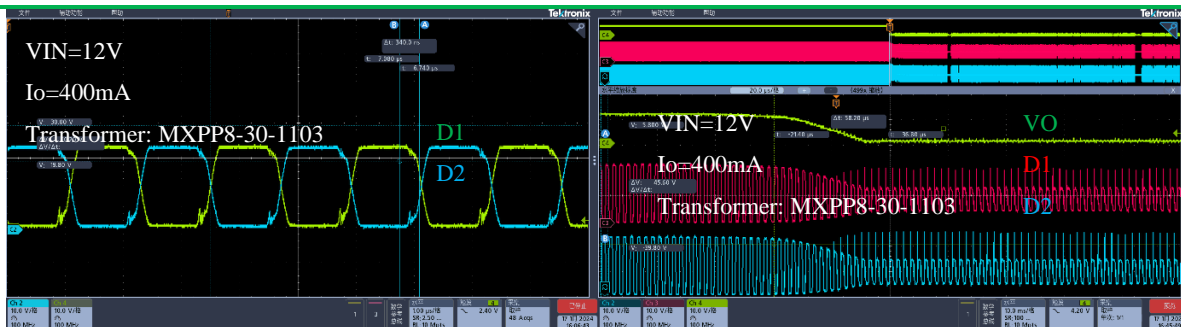

D1, D2 with Normal operation

Output short protection

MAXINMICRO

Restrictions on Product Use

- ◆ MAXIN micro is continually working to improve the quality and reliability of its products. Nevertheless, semiconductor devices in general can malfunction or fail due to their inherent electrical sensitivity and vulnerability to physical stress. It is the responsibility of the buyer, when utilizing MAXIN products, to comply with the standards of safety in making a safe design for the entire system, and to avoid situations in which a malfunction or failure of such MAXIN products could cause loss of human life, bodily injury or damage to property.
- ◆ In developing your designs, please ensure that MAXIN products are used within specified operating ranges as set forth in the most recent MAXIN products specifications.
- ◆ The information contained herein is subject to change without notice.

Version update record:

V10 The original version (preliminary)

MAXIN MICRO