



深圳市汉昇实业有限公司

SHENZHEN HANSHENG INDUSTRIAL CO.LTD.,

HS24S010B

规格书

DATASHEET

汉昇 HS	制作	审核	批准

版本：VER 1.0	
------------	--

深圳市汉昇实业有限公司

地址：深圳市南山区西丽镇牛成村 208 栋亿莱工业大厦 5 楼

电话：0755-86114312/86114313/86114313

传真：0755-86114314

网址：www.hsicm.com

1. 概述	2
2. 特点	2
3. 外形及接口引脚功能	3
4. 基本原理.....	5
5. 技术参数.....	5
6. 时序特性.....	6
7. 指令功能.....	11

Revised History

Part Number	Revisio	Revision Content	Revised on ""
*****J U46U232D	A ⁿ		201; -07-21

Contents

Revision History

Contents

- 1. General Description***
- 2. Mechanical Drawing***
- 3. Pin Description***
- 4. Electrical Characteristics***
- 5. Optical Characteristics***
- 6. Reliability***
- 7. Package Specifications***
- 8. Incoming Inspection standards***
- 9. Precautions When Using These TFT Display Modules***
- 10. Warranty***
- 11. Notice***

1. General Description

1.1 Description

HS20S010B is a 240RGBX320 dot-matrix TFT LCD module. This module is composed of a TFT LCD Panel, driver ICs, FPC and a Backlight unit.

1.2 Features

NO.	Item	Contents	Unit
1	LCD Size	2.1	inch
2	Display Mode	Normally black	-
3	Resolution	240(H)RGB x320(V)	pixels
4	Pixel pitch	0.1275(H) x 0.1275(V)	mm
5	Active area	31.1 (H) x 41.1 (V)	mm
6	Module size	136.6(H) x 162.1 (V) x 11 (D)	mm
7	Pixel arrangement	RGB Vertical stripe	-
8	Interface	4 Line SPI	-
9	Display Colors	65K	colors
10	Drive IC	ST7789V2	-
11	FONT IC	GT30L32S4W	
12	Luminance(cd/m ²)	400 (TYP)	Cd/m ²
13	Viewing Direction	All View	Best image
14	Backlight	4 White LED Parallel	-
15	Operating Temp.	-20°C~ + 70°C	°C
16	Storage Temp.	-30°C~+ 80°C	°C
17	Weight	11	g

版次	描述	日期
#A0	初版	2019/07/20
#A1		
#A2		

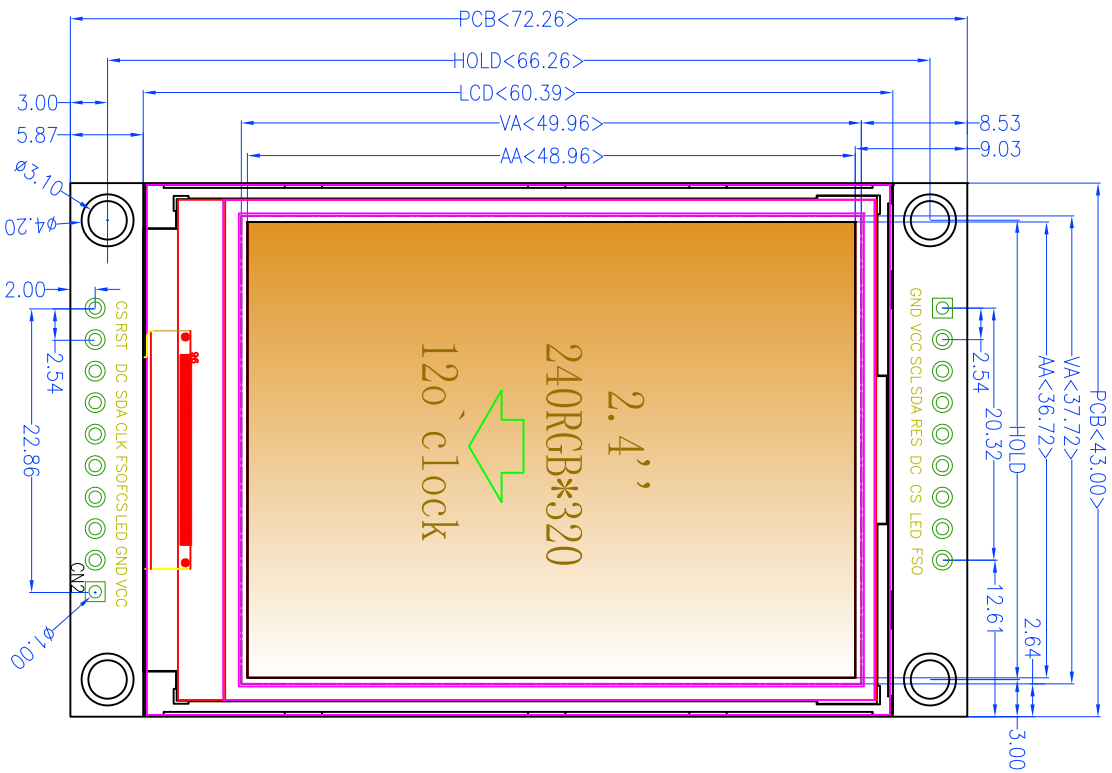

注意：默认不带字库，需要字库的请联系公司业务。不带字库的时候FSO、FCS悬空即可。

NOTE: 1. DISPLAY TYPE: 2.0' TFT	6. OPERATING TEMP: -20°C ~ +70°C.	深圳市汉昇实业有限公司	
2. INTERFACE: 4SPI/4SPI+FONT	7. STORAGE TEMP: -30°C ~ +80°C.	项目名称	LCM图
3. DRIVE METHOD: 240(H)RGB*320(V)	8. CONNECTOR: ST7789	型号	HS20S010B
4. OPERATING VOLTAGE: VOP=3.3V	9. ALL WITHOUT TOLERANCES. X±0.2	页序:	版本: #A1
5. POLARIZER MODE: TRANSMISSIVE/NORMALLY BLACK		制图: 1/1	审核:
			单位: mm
			比例: 1:1
			日期: 2019/07/20

CN1

1	GND	
2	VCC	
3	CLK	
4	SDA	
5	RES	
6	DC	
7	CS1	
8	BLK	
9	FSO	字库I/O
10	FCS	

CN2

1	VCC	
2	GND	
3	BLA	
4	FCS	
5	FSO	字库I/O
6	CLK	
7	SDA	
8	DC	
9	RES	
10	CS1	

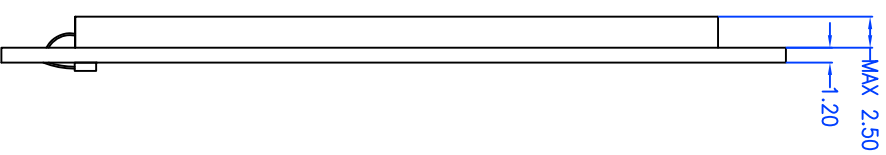
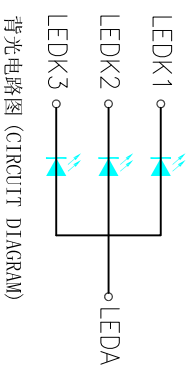

3. Pin Definition

Symbol	Symbol	Description
1	GND	Power Ground.
2	VCC	Power Supply for Analog 3.3V
3	SCL	This pin is used to be serial interface clock.
4	SDA	SPI interface input/output pin.
5	RES	This signal will reset the device, Signal is active low.
6	DC	Display data/command selection pin in 4-line serial interface.
7	CS	LCD Chip selection pin, Low enable, High disable
8	BLK	Backlight control switch, backlight on by default, low level off backlight
9	FSO	Font database data output
10	FCS	FONT IC Chip selection pin, Low enable, High disable

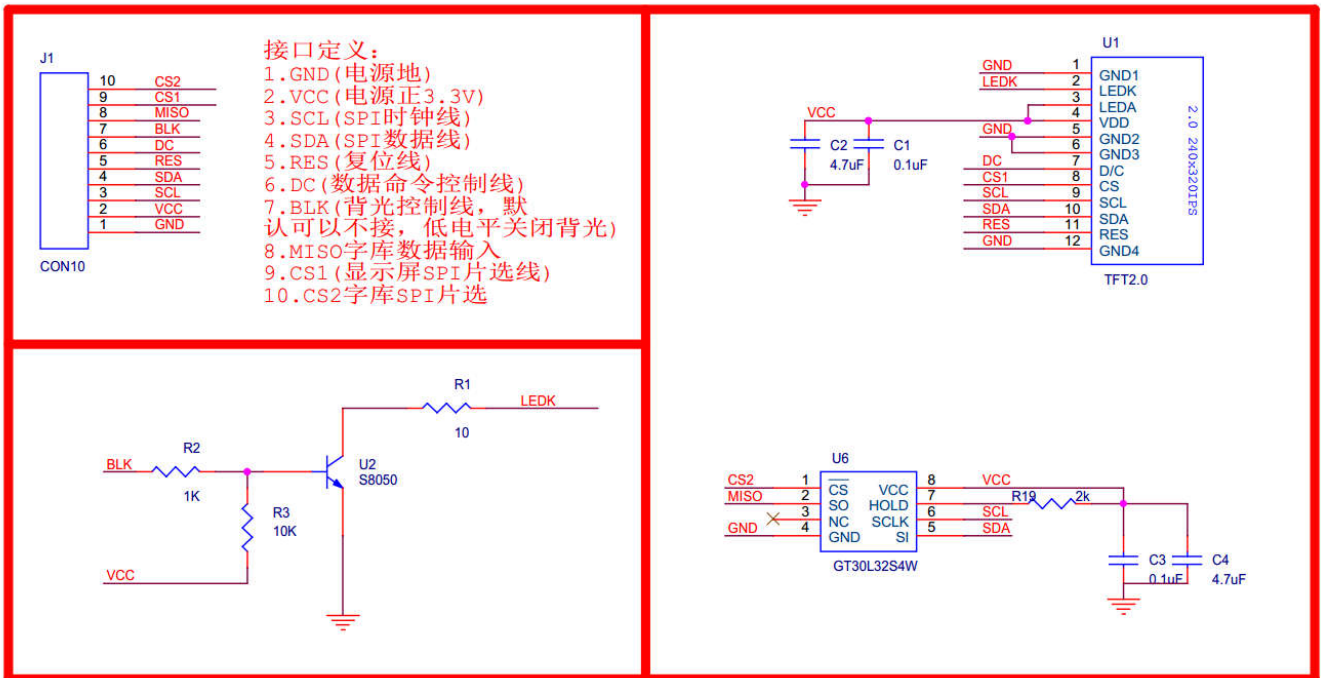

4. Electrical Characteristics

4.1 Absolute Maximum Ratings

Parameter	Symbol	Min	MAX	Unit	Notes
Supply Voltage (I/O)	VDD	-0.3	4.6	V	
Analog Supply Voltage	VDDIO	-0.3	4.6	V	
Logic Input Voltage	VIN	-0.3	VDDIO+0.5	V	
Operation Temperature	Top	-20	70	°C	
Storage Temperature	Tst	-30	80	°C	

4.2 Operating Conditions

Parameter	Symbol	Min	TYP	MAX	Unit	Notes
System Voltage	VDD	2.5	2.8	3.3	V	
Gate Driver High Voltage	VGH	12.2	-	14.97	V	
Gate Driver Low Voltage	VGL	-12.5	-	-7.16	V	
Operating Current for V _{DD}	I _{DD}	-	8	10	mA	
Sleep_In Mode VDD	I _{dd}	-	15	30	uA	
Sleep_In Mode VDDIO	I _{ddio}	-	5	10	uA	

4.3 Backlight Unit

Parameter	Symbol	Min	TYP	MAX	Unit	Notes
Voltage for LED backlight	VLED	2.9	3.0	3.1	V	
Current for LED backlight	I _{LED}	-	80	120	mA	4 LED
Power Consumption	P _{bl}	-	240	372	mW	1
Brightness	L _{br}	350	400	-	cd/m ²	2
LED Life time	-	20000	-	-	hr	3

Note:

1. Where I_{LED} =80mA , V_{LED}=3.0V , P_{bl}= I_{LED} x V_{LED}
2. Uniform measure condition:
 - a: Measure 9 point ,Measure location is show below:
 - b: Uniform=(Min brightness/Max brightness)x100%
 - c: Best Contrast.

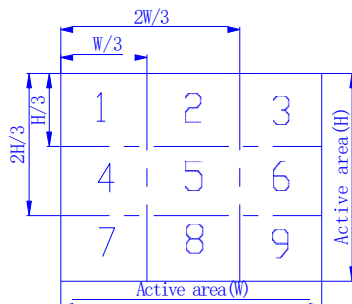

3. The environmental conducted under ambient air flow ,at Ta=25±2°C,60%RH±5%

4.4 Backlight Recommended Circuit

Motherboard driver backlight is need constant current circuit , if threated voltage screen after light brightness difference . Current and power consumption of the machine are inconsistent , so recommend a backlight driving circuit is best rated current . It is recommended to use IC (AW9364) . The reference circuit is as follows:

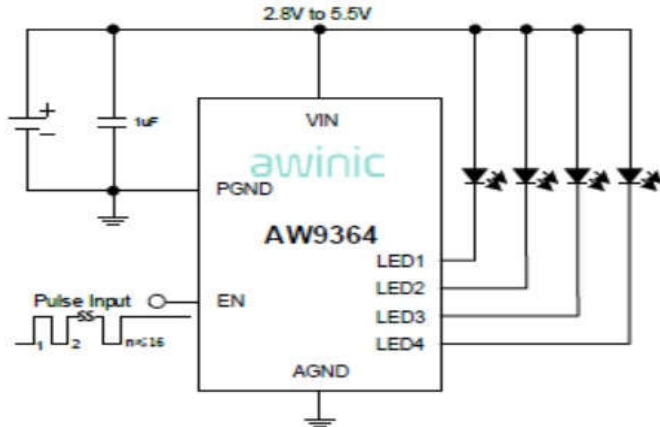

4.5 AC Timing Characteristic of The LCD

Serial interface Characteristics(4-line serial):

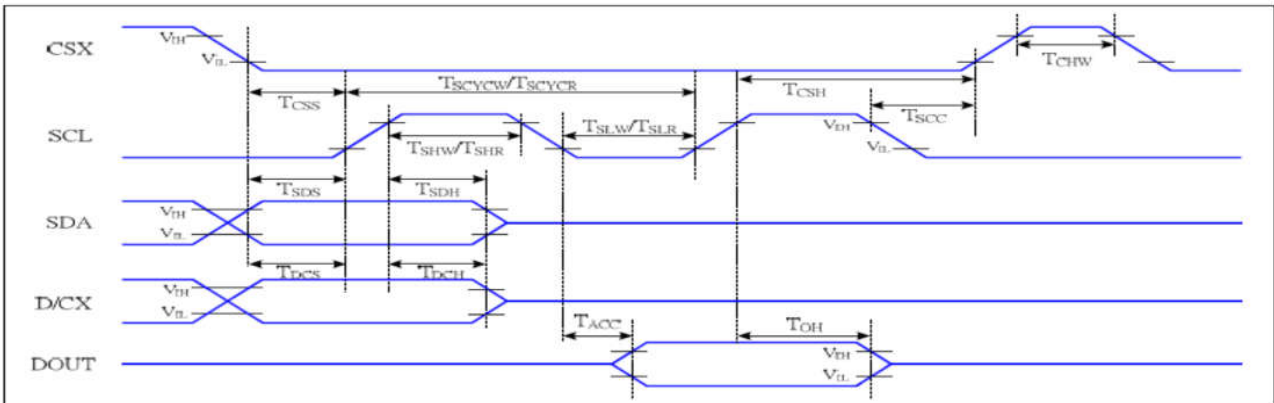

Signal	Symbol	Parameter	MIN	MAX	Unit	Description
CSX	T _{css}	Chip select setup time (write)	15		ns	
	T _{csh}	Chip select hold time (write)	15		ns	
	T _{css}	Chip select setup time (read)	60		ns	
	T _{scc}	Chip select hold time (read)	65		ns	
	T _{chw}	Chip select "H" pulse width	40		ns	
SCL	T _{scywr}	Serial clock cycle (Write)	16		ns	-write command & data ram
	T _{shw}	SCL "H" pulse width (Write)	7		ns	
	T _{slw}	SCL "L" pulse width (Write)	7		ns	
	T _{scywr}	Serial clock cycle (Read)	150		ns	-read command & data ram
	T _{shr}	SCL "H" pulse width (Read)	60		ns	
	T _{slr}	SCL "L" pulse width (Read)	60		ns	
D/CX	T _{dcS}	D/CX setup time	10		ns	
	T _{dch}	D/CX hold time	10		ns	
SDA (DIN)	T _{sdS}	Data setup time	7		ns	
	T _{sdH}	Data hold time	7		ns	
DOUT	T _{acc}	Access time	10	50	ns	For maximum CL=30pF
	T _{oh}	Output disable time	15	50	ns	For minimum CL=8pF

5. OPTICAL CHARACTERISTICS

Item	Symbol	Measuring Conditions		Min.	Typ.	Max.	Unit	Remark
Viewing Angle	θ	$\phi = 0^\circ$	25 °C	-	80	-	Deg	Note1
		$\phi = 180^\circ$	25 °C	-	80	-		
	θ	$\phi = 90^\circ$	25 °C	-	80	-		
		$\phi = 270^\circ$	25 °C	-	80	-		
Brightness	L_{br}	--	-	350	400	-	Cd/m2	
Luminance Uniformity	ΔL	--	-	70	75	-		
Contrast Ratio	CR	--	25 °C	640	800	-	--	Note2
Response Time	T_r+T_f	$\theta = 0^\circ$ $\phi = 0^\circ$	25 °C	-	30	40	ms	Note3
Color of CIE Coordinate	White	X	25 °C	-0.03	0.296	+0.03	--	BM-7A
		Y	25 °C		0.325			
	Red	X	25 °C		0.647			
		Y	25 °C		0.329			
	Green	X	25 °C		0.279			
		Y	25 °C		0.550			
	Blue	X	25 °C		0.134			
		Y	25 °C		0.123			
Transmittance (with polarizer)	--	--	--	-	4.5	-	%	--

Note 1 Definition of Viewing Angle:

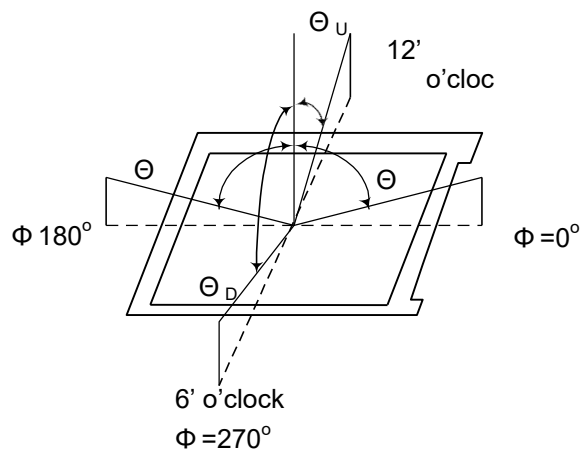

Note 2: Definition of Contrast Ratio (CR) :
measured at the center point of panel

$$CR = \frac{\text{Luminance with all pixels white}}{\text{Luminance with all pixels black}}$$

Note 3: Definition of Response Time : Sum of Tr and Tf :

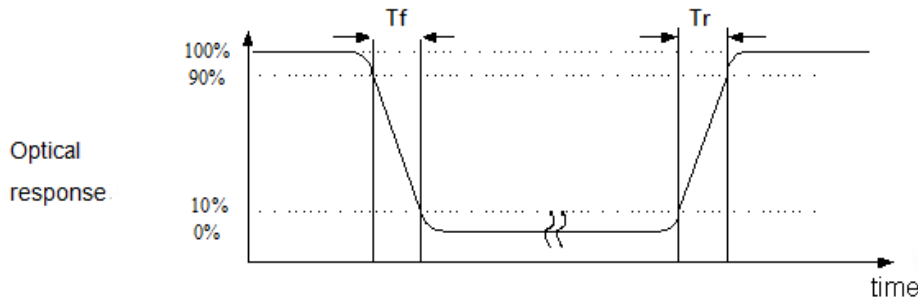

6. Reliability

Contents of Reliability Tests

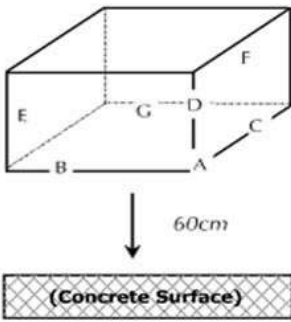
No.	Item	Conditions	Note
1	High Temperature Operation	70°C±2°C, 120 hrs	
2	Low Temperature Operation	-20°C±2°C, 120 hrs	
3	High Temperature Storage	80°C±2°C, 120 hrs	
4	Low Temperature Storage	-30°C±2°C, 120 hrs	
5	High Temperature /Humidity Operation	60°C±2°C, 90% RH, 120 hrs	
6	Temperature Cycling	-10°C→25°C→60°C→25°C→-10°C 30min 5min 30min 5min 30min 10 cycle.	
7	Vibration Test	Total fixed amplitude:1.5mm. Vibration Frequency:10~55Hz One cycle 60 seconds to 3 direction of X,Y,Z each 15 minutes.	
8	ESD Test	Air Discharge:Apple ±4KV with 5 times. Contact Discharge:Apple ±2KV with 5 times.	
9	Drop Test	To be measured after dropping from 60cm high on the concrete surface in packing state.  <i>Dropping method corner dropping:</i> <i>A corner: Once edge dropping.</i> <i>B, C, D edge: Once face dropping.</i> <i>E, F, G face: Once.</i>	

Note:

No charge on display and in operation under the following test condition.

Please note that the reliability test project requires the use of virgin samples

Condition : Unless otherwise specified ,tests will be conducted under the following condition.

Temperature:20°C±5°C.

Humidity:65±5%RH.

Tests will be not conducted under functioning state.

7. Package Specifications

Item		Quantity	
Module		300	per Primary Box
Holding Trays	(A)	15	per Primary Box
Total Trays	(B)	16	per Primary Box (Including 1 Empty Tray)
Primary Box	(C)	1~4	per Carton (4 as Major / Maximum)

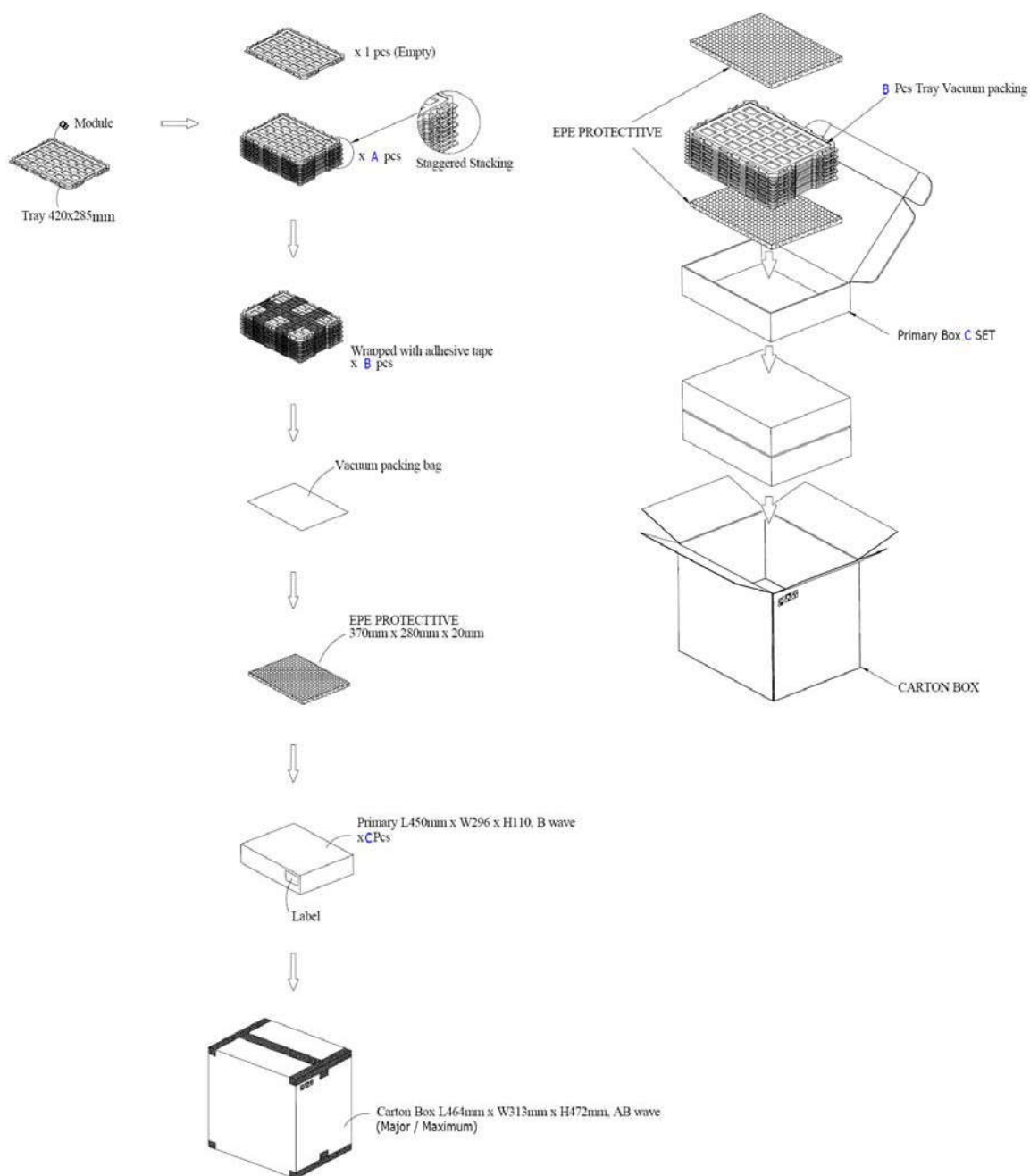

8. Incoming Inspection Standards

8.1. Inspection and Environment Conditions

8.1.1. Inspection Conditions:

- (1) Inspection Distance :35 cm±5cm
- (2) View Angle : Light-on Inspection Angle:±5°
Cosmetic Inspection Angle: ±45°

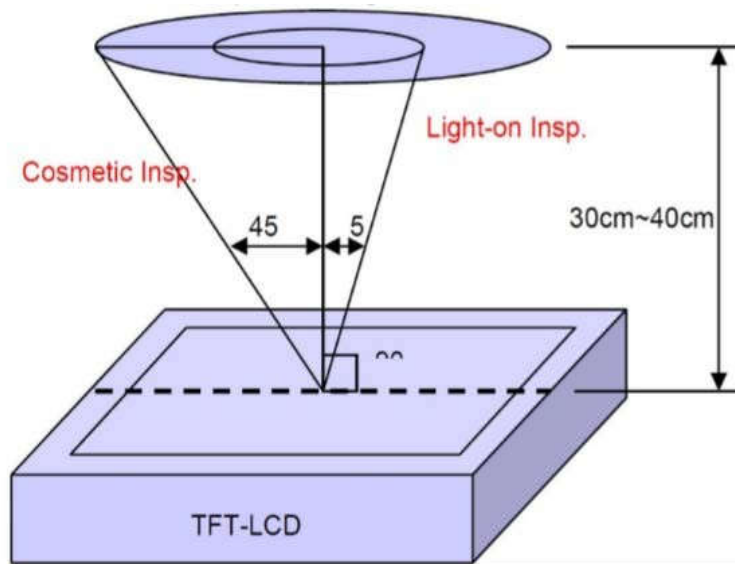

(perpendicular to LCD panel surface)

8.1.2 Environment Conditions:

Ambient Temperature		23°C±5°C
Ambient Humidity		55±10%RH
Ambient Illumination	Cosmetic Inspection	More than 600 Lux
	Functional Inspection	300~500 Lux

8.1.3 Sampling Conditions:

- (1) Lot Size:Quantity of shipment lot per model
- (2) Sampling Method:

Sampling Plan		MIL-STD-105E
		Normal Inspection, Single Sampling
		Level II
AQL	Major Defect	0.65%
	Minor Defect	1.5%

8.1.4 Inspection Criteria

8.1.4.1 Cosmetic Inspection(Panel):

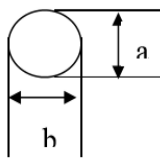
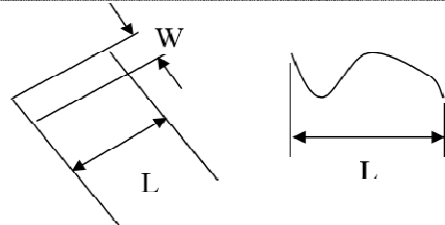
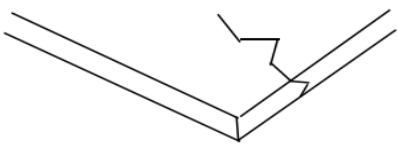
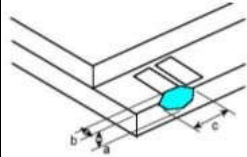
Check Item	Classification	Criteria(Unit: mm)																		
Black / White spot Foreign material (Round type) Pinholes Stain Particles inside cell.	Minor	 <table border="1" data-bbox="986 380 1377 712"> <thead> <tr> <th>Size</th> <th>Area</th> <th>Acc. Qty</th> </tr> </thead> <tbody> <tr> <td>$\phi \leq 0.10$</td> <td></td> <td>Ignore</td> </tr> <tr> <td>$0.10 < \phi \leq 0.15$</td> <td></td> <td>2</td> </tr> <tr> <td>$0.15 < \phi \leq 0.20$</td> <td></td> <td>1</td> </tr> <tr> <td>$0.20 < \phi$</td> <td></td> <td>0</td> </tr> <tr> <td>Total</td> <td></td> <td>2 no include $\phi \leq 0.10$</td> </tr> </tbody> </table> <p>$\phi = (a + b) / 2$</p> <p>Distance between 2 defects should more than 5mm apart.</p>	Size	Area	Acc. Qty	$\phi \leq 0.10$		Ignore	$0.10 < \phi \leq 0.15$		2	$0.15 < \phi \leq 0.20$		1	$0.20 < \phi$		0	Total		2 no include $\phi \leq 0.10$
Size	Area	Acc. Qty																		
$\phi \leq 0.10$		Ignore																		
$0.10 < \phi \leq 0.15$		2																		
$0.15 < \phi \leq 0.20$		1																		
$0.20 < \phi$		0																		
Total		2 no include $\phi \leq 0.10$																		
Black and White line Scratch Foreign material (Line type)	Minor	 <table border="1" data-bbox="799 1037 1316 1249"> <thead> <tr> <th>Length</th> <th>Width</th> <th>Acc. Qty</th> </tr> </thead> <tbody> <tr> <td>/</td> <td>$W \leq 0.03$</td> <td>Ignore</td> </tr> <tr> <td>$L \leq 2$</td> <td>$0.03 < W \leq 0.05$</td> <td>1</td> </tr> <tr> <td>/</td> <td>$0.05 < W$</td> <td>0</td> </tr> <tr> <td colspan="2">Total</td> <td>1</td> </tr> </tbody> </table> <p>Distance between 2 defects should more than 5mm apart. Scratches not viewable through the back of the display are acceptable.</p>	Length	Width	Acc. Qty	/	$W \leq 0.03$	Ignore	$L \leq 2$	$0.03 < W \leq 0.05$	1	/	$0.05 < W$	0	Total		1			
Length	Width	Acc. Qty																		
/	$W \leq 0.03$	Ignore																		
$L \leq 2$	$0.03 < W \leq 0.05$	1																		
/	$0.05 < W$	0																		
Total		1																		
Glass Crack	Minor	 <p>LCD with extensible crack line is unacceptable(When press the cracked LCD Area, the line will expand,we define it is extensible crack line)</p>																		
Glass Chipping Pad Area	Minor	 <table border="1" data-bbox="805 1818 1279 1921"> <thead> <tr> <th>Length and Width</th> <th>Acc. Qty</th> </tr> </thead> <tbody> <tr> <td>$c < 5.0, b < 0.4$</td> <td>Ignore</td> </tr> </tbody> </table>	Length and Width	Acc. Qty	$c < 5.0, b < 0.4$	Ignore														
Length and Width	Acc. Qty																			
$c < 5.0, b < 0.4$	Ignore																			

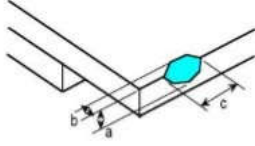
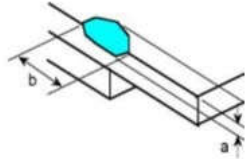
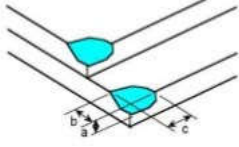
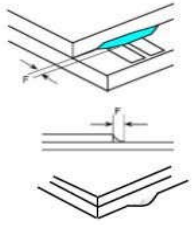
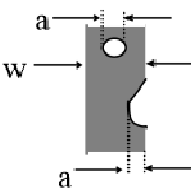
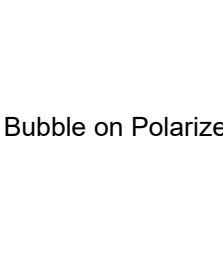
Check Item	Classification	Criteria(Unit: mm)										
Glass Chipping Rear Of Pad Area 	Minor	<table border="1"> <thead> <tr> <th>Length and Width</th> <th>Acc. Qty</th> </tr> </thead> <tbody> <tr> <td>$c > 3.0, b < 1.0$</td> <td>1</td> </tr> <tr> <td>$c < 3.0, b < 1.0$</td> <td>2</td> </tr> <tr> <td>$c < 3.0, b < 0.5$</td> <td>4</td> </tr> <tr> <td colspan="2">$a < \text{Glass Thickness}$</td> </tr> </tbody> </table>	Length and Width	Acc. Qty	$c > 3.0, b < 1.0$	1	$c < 3.0, b < 1.0$	2	$c < 3.0, b < 0.5$	4	$a < \text{Glass Thickness}$	
Length and Width	Acc. Qty											
$c > 3.0, b < 1.0$	1											
$c < 3.0, b < 1.0$	2											
$c < 3.0, b < 0.5$	4											
$a < \text{Glass Thickness}$												
Glass Chipping Except Pad Area 	Minor	<table border="1"> <thead> <tr> <th>Length and Width</th> <th>Acc. Qty</th> </tr> </thead> <tbody> <tr> <td>$c \leq 0.6, b < 5.0$</td> <td>Ignore</td> </tr> <tr> <td colspan="2">$a < \text{Glass Thickness}$</td> </tr> </tbody> </table>	Length and Width	Acc. Qty	$c \leq 0.6, b < 5.0$	Ignore	$a < \text{Glass Thickness}$					
Length and Width	Acc. Qty											
$c \leq 0.6, b < 5.0$	Ignore											
$a < \text{Glass Thickness}$												
Glass Corner Chipping 	Minor	<table border="1"> <thead> <tr> <th>Length and Width</th> <th>Acc. Qty</th> </tr> </thead> <tbody> <tr> <td>$c < 2.0, b < 1.5$</td> <td>Ignore</td> </tr> <tr> <td>$c < 1.5, b < 2$</td> <td>Ignore</td> </tr> <tr> <td colspan="2">$a < \text{Glass Thickness}$</td> </tr> </tbody> </table>	Length and Width	Acc. Qty	$c < 2.0, b < 1.5$	Ignore	$c < 1.5, b < 2$	Ignore	$a < \text{Glass Thickness}$			
Length and Width	Acc. Qty											
$c < 2.0, b < 1.5$	Ignore											
$c < 1.5, b < 2$	Ignore											
$a < \text{Glass Thickness}$												
Glass Burr 	Minor	<p>Glass burr don't affect assemble and module dimension.</p> <table border="1"> <thead> <tr> <th>Length</th> <th>Acc. Qty</th> </tr> </thead> <tbody> <tr> <td>$F < 0.5$</td> <td>Ignore</td> </tr> </tbody> </table>	Length	Acc. Qty	$F < 0.5$	Ignore						
Length	Acc. Qty											
$F < 0.5$	Ignore											
FPC Defect 	Minor	<ol style="list-style-type: none"> Dent , pinhole width $a < W/2$. (W:circuitry width) Open circuit is unacceptable. No oxidation, contamination and distortion. 										
Bubble on Polarizer 	Minor	<table border="1"> <thead> <tr> <th>Diameter</th> <th>Acc. Qty</th> </tr> </thead> <tbody> <tr> <td>$\phi \leq 0.15$</td> <td>Ignore</td> </tr> <tr> <td>$0.15 < \phi \leq 0.20$</td> <td>2</td> </tr> <tr> <td>$0.20 < \phi \leq 0.30$</td> <td>1</td> </tr> <tr> <td>$0.3 < \phi$</td> <td>None</td> </tr> </tbody> </table>	Diameter	Acc. Qty	$\phi \leq 0.15$	Ignore	$0.15 < \phi \leq 0.20$	2	$0.20 < \phi \leq 0.30$	1	$0.3 < \phi$	None
Diameter	Acc. Qty											
$\phi \leq 0.15$	Ignore											
$0.15 < \phi \leq 0.20$	2											
$0.20 < \phi \leq 0.30$	1											
$0.3 < \phi$	None											

Check Item	Classification	Criteria(Unit: mm)										
Dent on Polarizer	Minor	<table border="1"> <thead> <tr> <th>Diameter</th> <th>Acc. Qty</th> </tr> </thead> <tbody> <tr> <td>$\varphi \leq 0.15$</td> <td>Ignore</td> </tr> <tr> <td>$0.15 < \varphi \leq 0.20$</td> <td>2</td> </tr> <tr> <td>$0.20 < \varphi \leq 0.30$</td> <td>1</td> </tr> <tr> <td>$0.3 < \varphi$</td> <td>None</td> </tr> </tbody> </table>	Diameter	Acc. Qty	$\varphi \leq 0.15$	Ignore	$0.15 < \varphi \leq 0.20$	2	$0.20 < \varphi \leq 0.30$	1	$0.3 < \varphi$	None
Diameter	Acc. Qty											
$\varphi \leq 0.15$	Ignore											
$0.15 < \varphi \leq 0.20$	2											
$0.20 < \varphi \leq 0.30$	1											
$0.3 < \varphi$	None											
Screen deformation 	/	<p>Test for insertion of plug gauge at highest warping point: $H \leq 0.25\text{mm}$ The client has special requirements, according to drawing.</p>										
Bezel	/	<p>1.No rust, distortion on the Bezel. 2.No visible fingerprints, stains or other contamination.</p>										
Touch Panel	/	<p>D:Diameter W: width L: length 1.Spot: $D \leq 0.2$ is acceptable $0.2 < D \leq 0.3$, acceptable Inspection and Environment Conditions 2dots are acceptable and the distance between defects Should more than 5mm. $D > 0.3$ is unacceptable 2.Dent: $D > 0.3$ is unacceptable. 3.Scratch: $W \leq 0.03, L \leq 10$ is acceptable, $0.03 < W \leq 0.1, L \leq 10$, acceptable Inspection and Environment Conditions Distance between 2 defects should more than 5 mm. $W > 0.1$ is unacceptable.</p>										
PCB	/	<p>1.No distortion or contamination on PCB terminals. 2.All components on PCB must same as documented on the BOM/component layout. 3.Follow IPC-A-600F.</p>										
Soldering	/	Follow IPC-A-610C standard.										
Leak	/	Yellow light, OK。 White light, According to the limit sample										