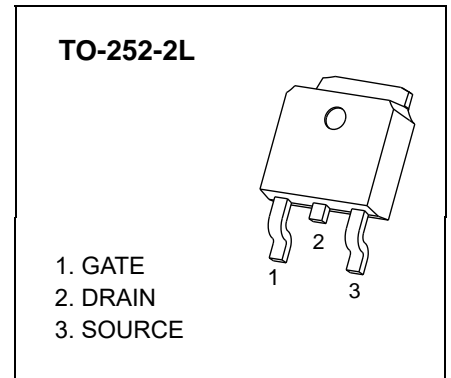

**TO-252-2L Plastic-Encapsulate MOSFETS****CJU02N60 N-Channel Power MOSFET**

$V_{(BR)DSS}$	$R_{DS(on)MAX}$	$I_D$
600V	4.4Ω@10V	2A

**GENERAL DESCRIPTION**

The CJU02N60 is an N-channel mode power MOSFET using advanced technology to provide costumers with planar stripe. This technology specializes in allowing a minimum on-state resistance and superior switching performance. It also can withstand high energy pulse in the avalanche and commutation mode. The CJU02N60 is universally applied in high efficiency switch mode power supply.

**FEATURE**

- Excellent package for good heat dissipation
- High switching speed
- 100% avalanche tested

**APPLICATION**

- Power switching application
- DC/DC converters

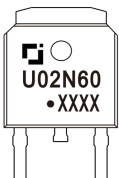
**MARKING**

CJU02N60= Device code  
Solid dot = Green molding compound device,  
if none, the normal device  
XXXX= C o d e

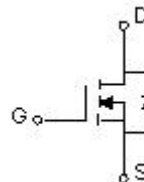
**EQUIVALENT CIRCUIT****Maximum ratings ( $T_a=25^\circ\text{C}$  unless otherwise noted)**

Parameter	Symbol	Value	Unit
Drain-Source voltage	$V_{DS}$	600	V
Gate-Source Voltage	$V_{GS}$	±20	
Continuous Drain Current	$I_D$	2	A
Pulsed Drain Current	$I_{DM}$	8	
Power Dissipation	$P_D$	1.25	
Single Pulsed Avalanche Energy*	$E_{AS}$	128	mJ
Thermal Resistance from Junction to Ambient	$R_{\theta JA}$	100	$^\circ\text{C/W}$
Junction Temperature	$T_J$	150	$^\circ\text{C}$
Storage Temperature	$T_{stg}$	-50 ~+150	

\* $E_{AS}$  condition:  $T_J=25^\circ\text{C}$ ,  $V_{DD}=50\text{V}$ ,  $L=64\text{mH}$ ,  $I_{AS}=2\text{A}$ ,  $R_G=25\Omega$

### Electrical characteristics (T<sub>a</sub>=25°C unless otherwise noted)

Parameter	Symbol	Test Condition	Min	Typ	Max	Unit
Drain-Source Breakdown Voltage	V <sub>(BR)DSS</sub>	V <sub>GS</sub> = 0V, I <sub>D</sub> =250μA	600			V
Gate-Threshold Voltage (note1)	V <sub>GS(th)</sub>	V <sub>DS</sub> =V <sub>GS</sub> , I <sub>D</sub> =250μA	2.0		4.0	
Gate-Body Leakage Current (note1)	I <sub>GSS</sub>	V <sub>DS</sub> =0V, V <sub>GS</sub> =±20V			±100	nA
Zero Gate Voltage Drain Current	I <sub>DSS</sub>	V <sub>DS</sub> =600V, V <sub>GS</sub> =0V			25	μA
Drain-Source On-State Resistance (note1)	R <sub>DS(on)</sub>	V <sub>GS</sub> =10V, I <sub>D</sub> =1A		3.5	4.4	Ω
Forward Transconductance (note1)	g <sub>FS</sub>	V <sub>DS</sub> =50V, I <sub>D</sub> =1A	1			S
Input Capacitance (note2)	C <sub>iSS</sub>	V <sub>DS</sub> =25V, V <sub>GS</sub> =0V, f =1MHz		435		pF
Output Capacitance (note2)	C <sub>oss</sub>			56		
Reverse Transfer Capacitance (note2)	C <sub>rSS</sub>			9.2		
Turn-On Delay Time (note2)	t <sub>d(on)</sub>	V <sub>DD</sub> =300V, I <sub>D</sub> =2A, V <sub>GS</sub> =10V, R <sub>G</sub> =18Ω		12		ns
Rise Time (note2)	t <sub>r</sub>			21		
Turn-Off Delay Time (note2)	t <sub>d(off)</sub>			30		
Fall Time (note2)	t <sub>f</sub>			24		
Forward on Voltage(note1)	V <sub>SD</sub>	V <sub>GS</sub> =0V, I <sub>S</sub> =2A			1.6	V

**Notes:**

1. Pulse Test : Pulse Width≤300μs, duty cycle ≤2%.
2. These parameters have no way to verify.

# Typical Characteristics

Output Characteristics

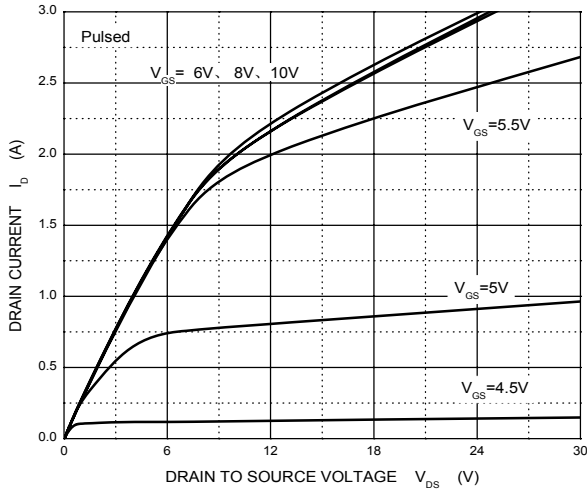

Transfer Characteristics

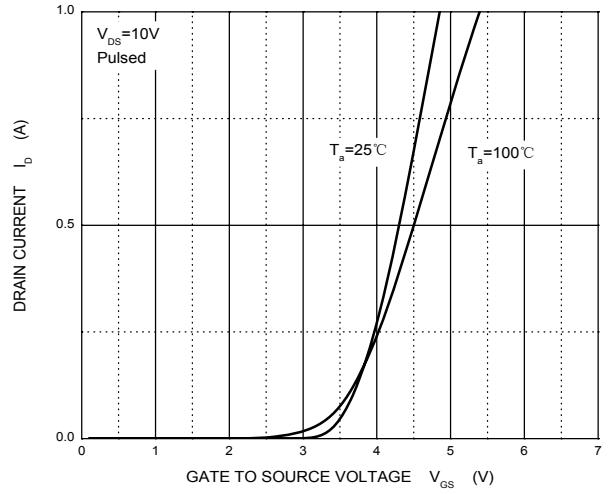

$R_{DS(ON)}$  —  $I_D$

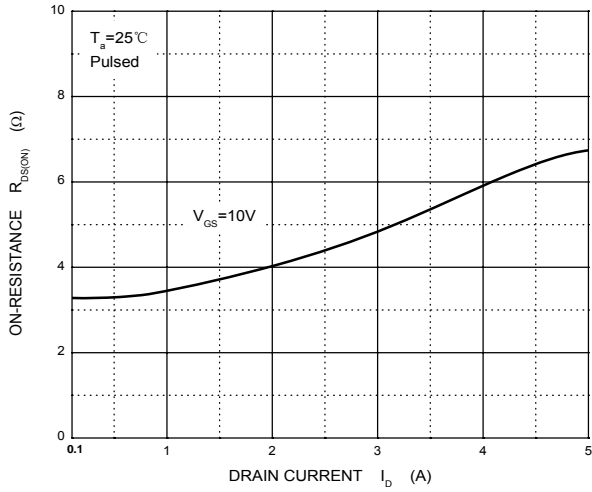

$R_{DS(ON)}$  —  $V_{GS}$

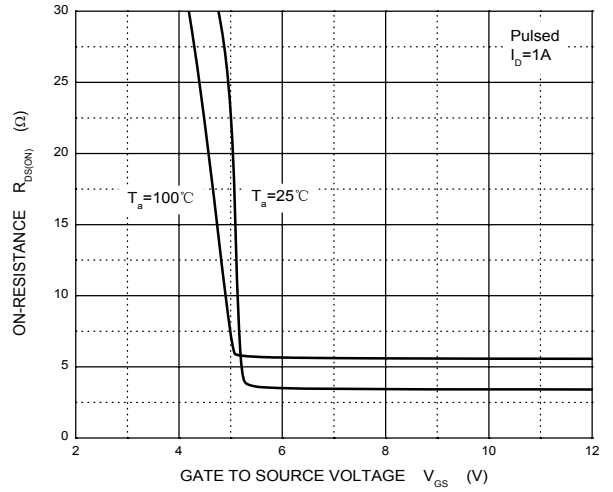

$I_S$  —  $V_{SD}$

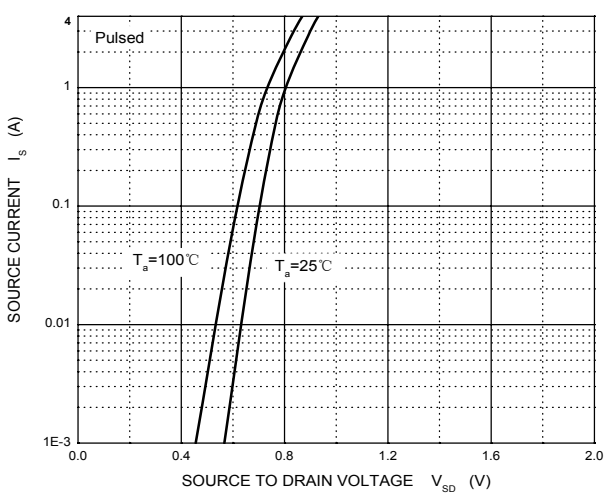

Threshold Voltage

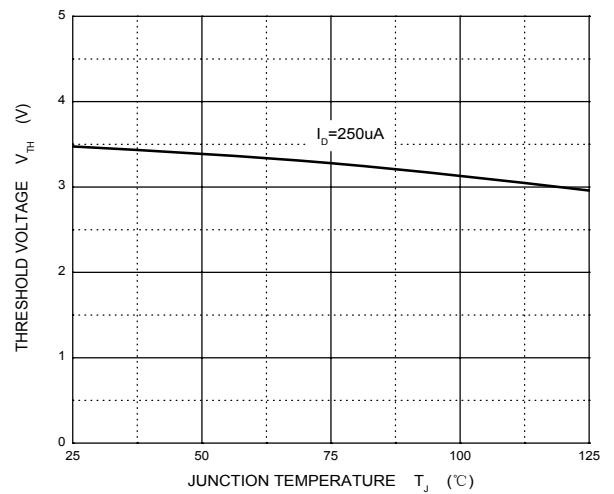

## TO-252-2L Package Outline Dimensions

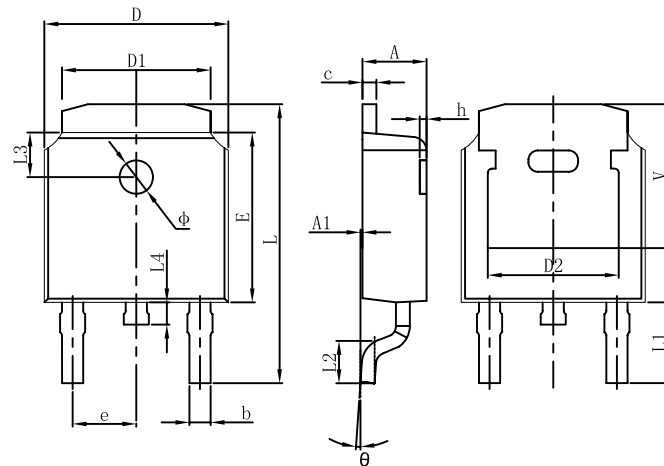

Symbol	Dimensions In Millimeters		Dimensions In Inches	
	Min.	Max.	Min.	Max.
A	2.200	2.400	0.087	0.094
A1	0.000	0.127	0.000	0.005
b	0.635	0.770	0.025	0.030
c	0.460	0.580	0.018	0.023
D	6.500	6.700	0.256	0.264
D1	5.100	5.460	0.201	0.215
D2	4.830 REF.		0.190 REF.	
E	6.000	6.200	0.236	0.244
e	2.186	2.386	0.086	0.094
L	9.712	10.312	0.382	0.406
L1	2.900 REF.		0.114 REF.	
L2	1.400	1.700	0.055	0.067
L3	1.600 REF.		0.063 REF.	
L4	0.600	1.000	0.024	0.039
Φ	1.100	1.300	0.043	0.051
θ	0°	8°	0°	8°
h	0.000	0.300	0.000	0.012
V	5.250 REF.		0.207 REF.	

## TO-252-2L Suggested Pad Layout

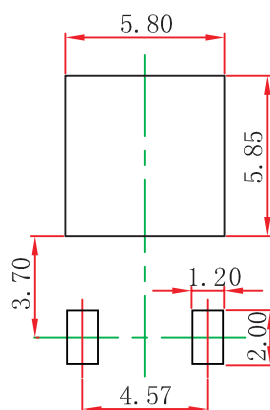

**Note:**

1. Controlling dimension: in millimeters.
2. General tolerance:  $\pm 0.05\text{mm}$ .
3. The pad layout is for reference purposes only.

**NOTICE**

JSCJ reserves the right to make modifications, enhancements, improvements, corrections or other changes without further notice to any product herein. JSCJ does not assume any liability arising out of the application or use of any product described herein.

# TO-252-2L Tape and Reel

## TO-252 Embossed Carrier Tape

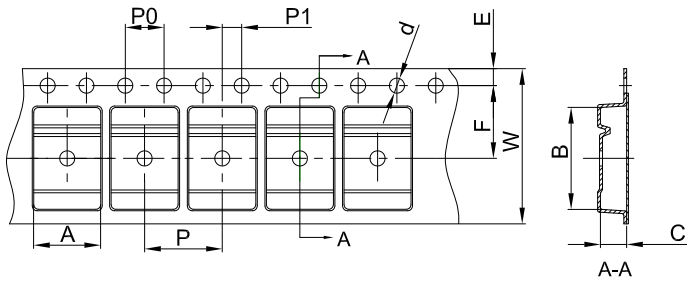

### Packaging Description:

TO-252 parts are shipped in tape. The carrier tape is made from a dissipative (carbon filled) polycarbonate resin. The cover tape is a multilayer film (Heat Activated Adhesive in nature) primarily composed of polyester film, adhesive layer, sealant, and anti-static sprayed agent. These reeled parts in standard option are shipped with 25,00 units per 13" or 33.0 cm diameter reel. The reels are clear in color and is made of polystyrene plastic (anti-static coated).

Dimensions are in millimeter										
Pkg type	A	B	C	d	E	F	P0	P	P1	W
TO-252	6.90	10.50	2.70	Ø1.55	1.75	7.50	4.00	8.00	2.00	16.00

## TO-252 Tape Leader and Trailer

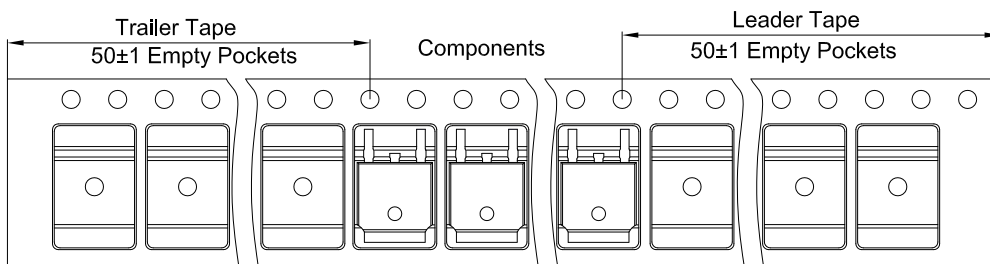

## TO-252 Reel

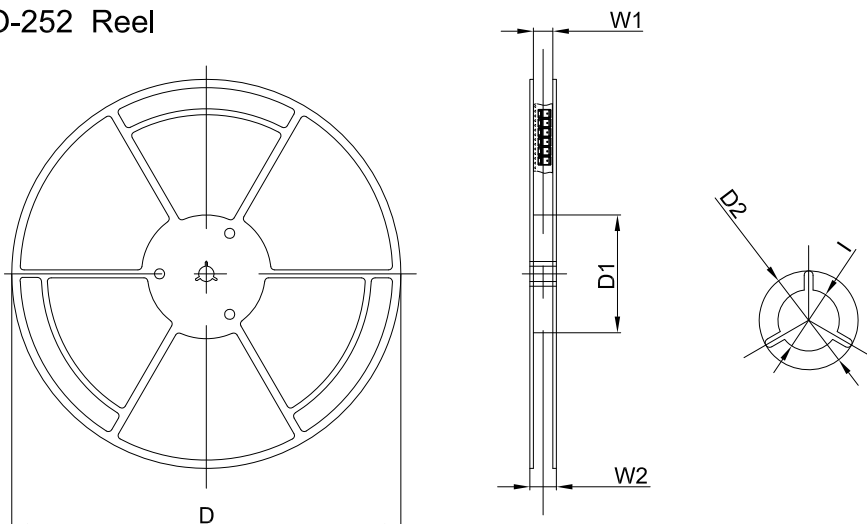

Dimensions are in millimeter						
Reel Option	D	D1	D2	W1	W2	I
13" Dia	330.00	100.00	Ø21.00	16.40	21.00	Ø13.00

REEL	Reel Size	Box	Box Size(mm)	Carton	Carton Size(mm)	G.W.(kg)
2,500 pcs	13inch	2,500 pcs	340×336×29	25,000 pcs	353×346×365	