



Applications Note: SY7400 60V High Current Boost LED Driver

General Description

SY7400 is a DC/DC step-up converter that delivers an accurate constant current for driving LEDs. Operation at a fixed switching frequency of 400kHz allows the device to be used with small value external ceramic capacitors and inductor. LEDs connected in series are driven with a regulated current set by the external resistor. The SY7400 is ideal for driving up to fifteen white LEDs in series or up to 60V.

Ordering Information

SY7400 □(□□)□
 □ Temperature Code
 □ Package Code
 □ Optional Spec Code

Ordering Number	Package type	Note
SY7400FCC	SO8E	----

Features

- Input voltage range 5 to 60V
- Switch current limit 1.2A
- Drives LED strings up to 60V
- 400kHz fixed frequency minimizes the external components
- Internal softstart limits the inrush current
- Open LED overvoltage protection
- RoHS Compliant and Halogen Free
- Compact package: SO8E

Applications

- Handheld Devices
- Portable lighting

Typical Applications

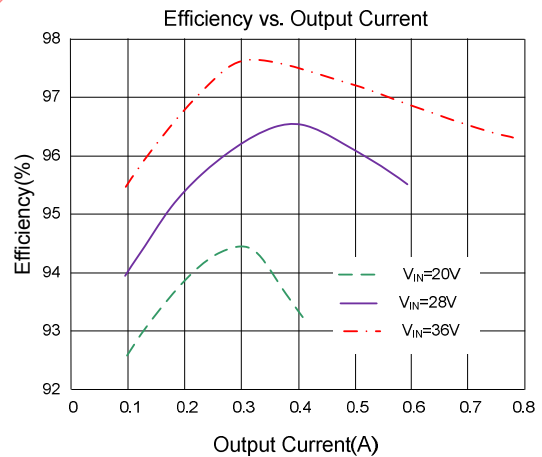
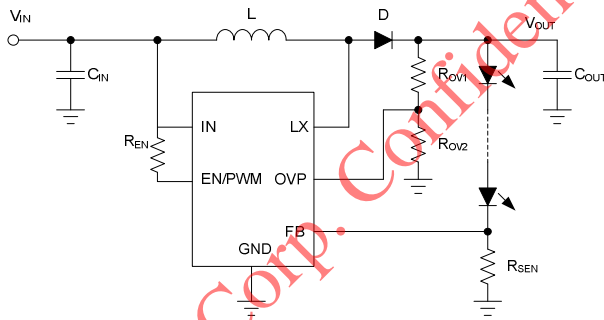
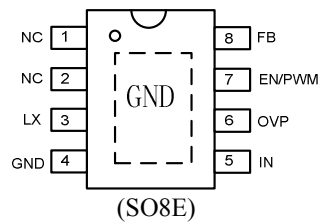

Figure.1 Schematic Diagram

Pinout (top view)



Top Mark: AYQxyz (Device code: AYQ, x=year code, y=week code, z=lot number code)

Pin Name	Pin Number	Pin Description
NC	1	No connect.
NC	2	No connect.
LX	3	Inductor node. Connect an inductor between IN pin and LX pin.
GND	4	Ground pin.
IN	5	Input pin. Decouple this pin to GND pin with 1uF ceramic capacitor.
OVP	6	Over voltage protection. The typical value is 60V.
EN/PWM	7	Enable and dimming control.
FB	8	Feedback pin. Connect a resistor R1 between FB and GND to program the output current: $I_{OUT}=0.2V/R_{SEN}$.

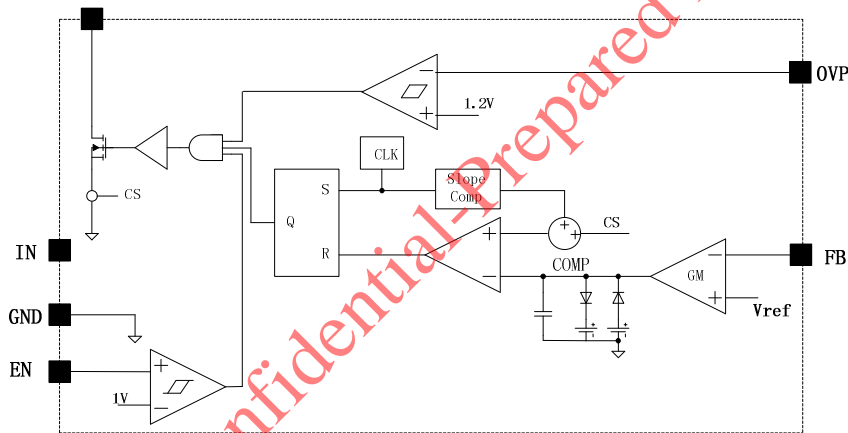

Absolute Maximum Ratings (Note 1)

LX,IN,EN	-----	63V
All other pins	-----	4V
Power Dissipation, P_d @ $T_A = 25^\circ\text{C}$, SO8E-	-----	3.3W
Package Thermal Resistance (Note 2)		
θ_{JA}	-----	30°C/W
θ_{JC}	-----	10°C/W
Junction Temperature Range	-----	-40 to 150°C
Lead Temperature (Soldering, 10 sec.)	-----	260°C
Storage Temperature Range	-----	-65°C to 150°C

Recommended Operating Conditions (Note 3)

Input Voltage Supply	-----	--5V to 60V
All other pins	-----	3.6V
Junction Temperature Range	-----	-40°C to 125°C
Ambient Temperature Range	-----	-40°C to 85°C

Electrical Characteristics

($V_{IN} = 12V$, $T_A = 25^\circ C$, unless otherwise specified)

Parameter	Symbol	Conditions	Min	Typ	Max	Unit
Input Voltage Range	V_{IN}		5		60	V
Quiescent Current	I_Q	$V_{FB}=0V$		0.75		mA
Shutdown Current	I_{SHDN}	EN=0		20		uA
Feedback Reference Voltage	V_{REF}		196	200	204	mV
FB Input Current	I_{FB}	$V_{FB}=0V$			1	uA
Low Side Main FET RON	$R_{DS(ON)}$			650		mΩ
Main FET Current Limit	I_{LIM}			1.2		A
EN Rising Threshold	V_{ENH}		1.8			V
EN Falling Threshold	V_{ENL}				0.4	V
Input UVLO ON Threshold	V_{UVLO}			4.5		V
Input UVLO OFF Threshold	V_{UVLO}			4.3		V
Oscillator Frequency	F_{OSC}	$I_{OUT}=100mA$		400		kHz
Min On Time				150		ns
Max Duty Cycle				95		%
Thermal Shutdown	T_{SD}			150		°C
Thermal Hysteresis	T_{HYST}			20		°C
OVP Rising Threshold	V_{OVP}			1.2		V
OVP Rising Hysteresis	$V_{OVP,HYS}$			50		mV

Note 1: Stresses beyond the “Absolute Maximum Ratings” may cause permanent damage to the device. These are stress ratings only. Functional operation of the device at these or any other conditions beyond those indicated in the operational sections of the specification is not implied. Exposure to absolute maximum rating conditions for extended periods may affect device reliability.

Note 2: θ_{JA} is measured in the natural convection at $T_A = 25^\circ C$ on a low effective single layer thermal conductivity test board of JEDEC 51-3 thermal measurement standard.

Note 3: The device is not guaranteed to function outside its operating conditions.

Typical Performance Characteristics

($V_{out}=41.5V$, $I_{LED}=0.26A$)

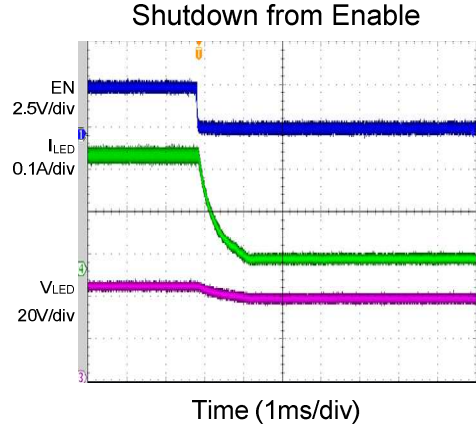
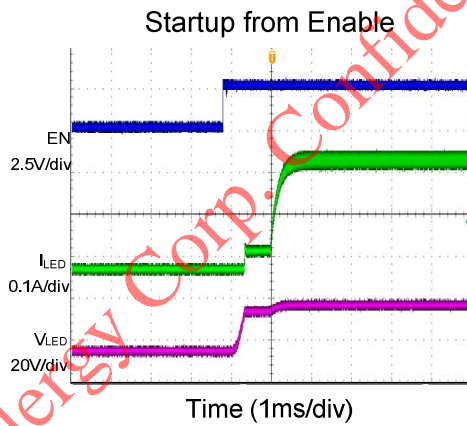
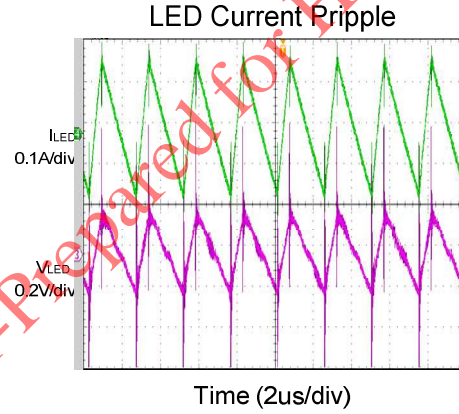
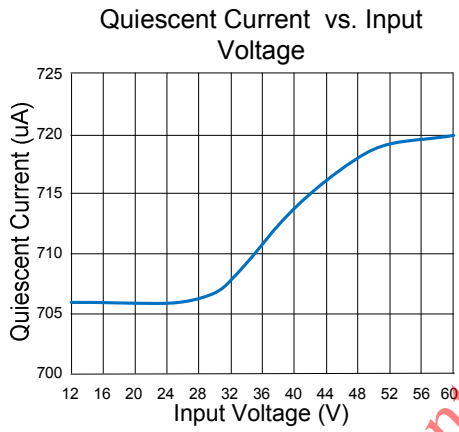
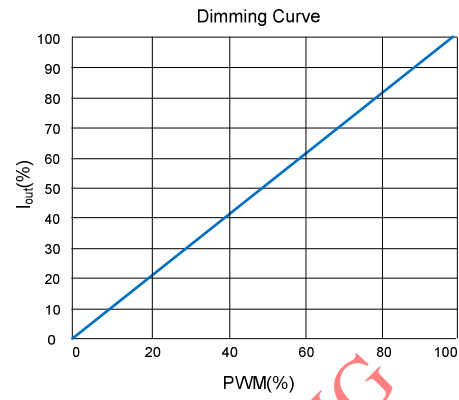
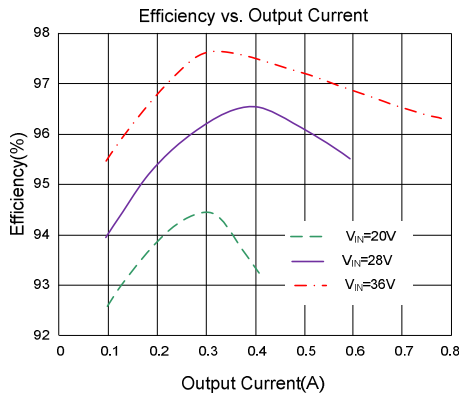

Starup from V_{IN}

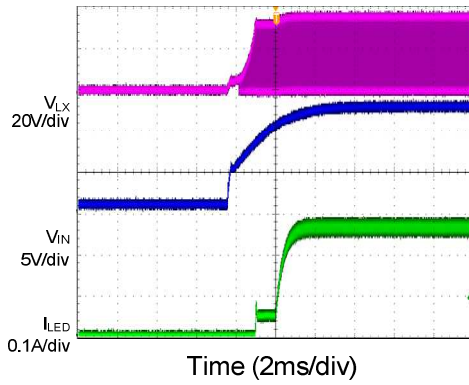

Shutdown from V_{IN}

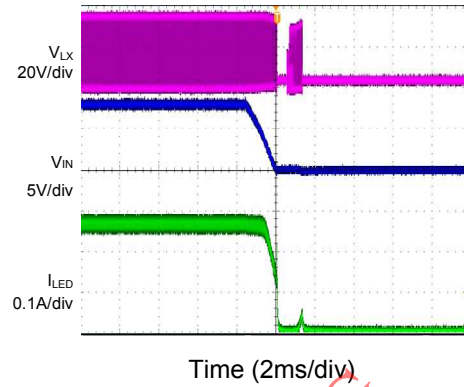

Open LED Protection

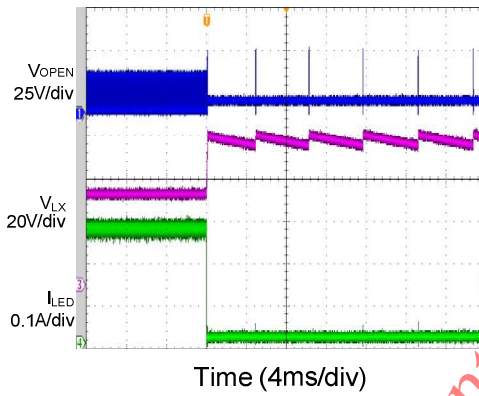

Silergy Corp. Confidential-Prepared for HG

Applications Information

Because of the high integration in the SY7400 IC, the application circuit based on this regulator IC is rather simple. Only input capacitor C_{IN} , output capacitor C_{OUT} , inductor L , Schottky diode D and sense resistors R_{SEN} need to be selected for the targeted applications specifications.

Sense resistor R_1 :

Choose R_{SEN} to program the proper LED Current. The R_1 can be calculated to be:

$$R_{SEN} = \frac{V_{REF}}{I_{LED}}$$

I_{LED} is the average LED current.

Input capacitor C_{IN} :

The ripple current through input capacitor is calculated as:

$$I_{CIN_RMS} = \frac{V_{IN} \cdot (V_{OUT} - V_{IN})}{2\sqrt{3} \cdot L \cdot F_{SW} \cdot V_{OUT}}$$

A typical X7R or better grade ceramic capacitor with larger than 4.7uF capacitance can handle this ripple current well. To minimize the potential noise problem, place this ceramic capacitor really close to the IN and GND pins. Care should be taken to minimize the loop area formed by C_{IN} , and IN/GND pins.

Output capacitor C_{OUT} :

The output capacitor is selected to handle the output ripple noise requirements. This ripple voltage is related to the capacitor's capacitance and its equivalent series resistance (ESR). For the best performance, it is recommended to use X7R or better grade low ESR ceramic capacitor. The voltage rating of the output capacitor should be higher than the maximum output voltage. The minimum required capacitance can be calculated as:

$$C_{OUT} = \frac{I_{OUT,MAX} \cdot (V_{OUT} - V_{IN})}{F_{SW} \cdot V_{OUT} \cdot V_{RIPPLE}}$$

V_{RIPPLE} is the peak to peak output ripple.

For LED applications, the equivalent resistance of the LED is typically low. The output capacitance should be large enough to attenuate the ripple current through LED. A capacitor larger than 2.2uF is recommended.

Inductor L :

There are several considerations in choosing this inductor.

- 1) Choose the inductance to provide the desired ripple current. It is suggested to choose the ripple current to be about 40% of the average input current. The inductance is calculated as:

$$L = \left(\frac{V_{IN}}{V_{OUT}} \right)^2 \frac{(V_{OUT} - V_{IN})}{F_{SW} \times I_{OUT,MAX} \times 40\%}$$

Where F_{SW} is the switching frequency and $I_{OUT,MAX}$ is the maximum load current.

The SY7400 regulator IC is quite tolerant of different ripple current amplitude. Consequently, the final choice of inductance can be slightly off the calculation value without significantly impacting the performance.

- 2) The saturation current rating of the inductor must be selected to be greater than the peak inductor current under full load conditions.

$$I_{SAT,MIN} > \left(\frac{V_{OUT}}{V_{IN}} \right) \times I_{OUT,MAX} + \left(\frac{V_{IN}}{V_{OUT}} \right) \frac{(V_{OUT} - V_{IN})}{2 \times F_{SW} \times L}$$

- 3) The DCR of the inductor and the core loss at the switching frequency must be low enough to achieve the desired efficiency requirement. It is desirable to choose an inductor with DCR < 50mohm to achieve a good overall efficiency.

Schottky Diode D :

Because of high switching speed of SY7400, a Schottky diode with low forward voltage drop and fast switching speed is desirable for the application. The voltage rating of the diode must be higher than maximum output voltage. The diode's average and peak current rating should exceed the average output current and peak inductor current.

Dimming Control

SY7400 offers several different dimming schemes for LED brightness control. One way is to apply a PWM signal to the EN/PWM pin. SY7400 adopts direct PWM dimming control as shown in Fig.2. The EN/PWM directly controls the driver of power MOSFET. The internal MOSFET turns off when EN/PWM signal is low. And the MOSFET resumes switching when EN/PWM signal is high.

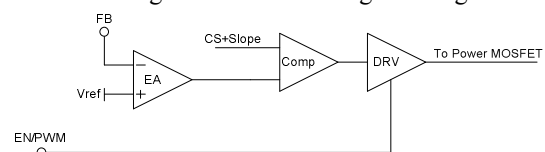

Figure 2

Another way is to use a DC voltage as shown in Fig.3. The LED current decreases as the DC voltage rises. The relationship between LED current and DC voltage is:

$$I_{LED} = \frac{V_{REF} \times (R_1 + R_2) - V_{DC} \times R_1}{R_2 \times R_{FB}}$$

Where V_{REF} is the 200mV internal reference voltage, V_{DC} is the dimming DC voltage.

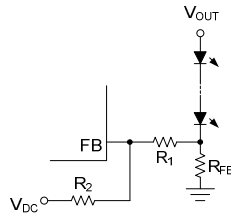

Figure 3

A filtered PWM signal can be used substituted the DC input as shown in Fig.4. To better filter out the AC components of the PWM signal, it is recommend choosing the same value for R2 and R3 and the cut-off frequency of the low pass filter (formed by R2//R3 and C1) to be well below the dimming signal frequency. The LED current decreases as the duty cycle increases. The LED current can be calculated using equation below:

$$I_{LED} = \frac{V_{REF} \times (R_1 + R_2 + R_3) - V_{PWM} \times Duty \times R_1}{(R_2 + R_3) \times R_{FB}}$$

Where V_{REF} is the 200mV internal reference voltage, V_{PWM} is the high voltage level of PWM signal, Duty is the duty cycle of PWM signal.

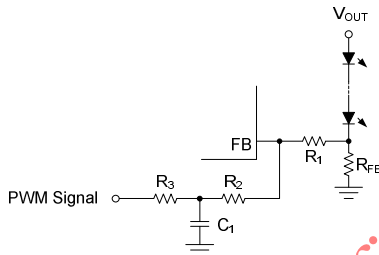

Figure 4

Layout Design:

The layout design of SY7400 regulator is relatively simple. For the best efficiency and minimum noise problems, we should place the following components close to the IC: C_{IN} , C_{OUT} , L, R_{SEN} and D.

- 1) It is desirable to maximize the PCB copper area connecting to GND pin to achieve the best thermal and noise performance. If the board space allowed, a ground plane is highly desirable.
- 2) C_{IN} must be close to Pins IN and GND. The loop area formed by C_{IN} and GND must be minimized.
- 3) Minimize the loop area of LX, D, C_{OUT} and GND.
- 4) The PCB copper area associated with LX pin must be minimized to avoid the potential noise problem.
- 5) The components R_{SEN} and the trace connecting to the FB pin must not be adjacent to the LX net on the PCB layout to avoid the noise problem.
- 6) If the system chip interfacing with the EN pin has a high impedance state at shutdown mode and the IN pin is connected directly to a power source such as a Li-Ion battery, it is desirable to add a pull down 1Mohm resistor between the EN and GND pins to prevent the noise from falsely turning on the regulator at shutdown mode

SO8E Package Outline & PCB layout

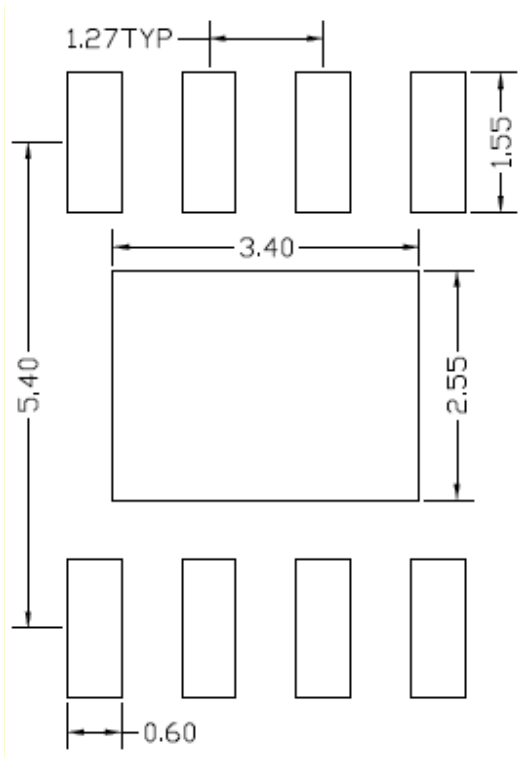

**Recommended PCB Layout
(Reference Only)**

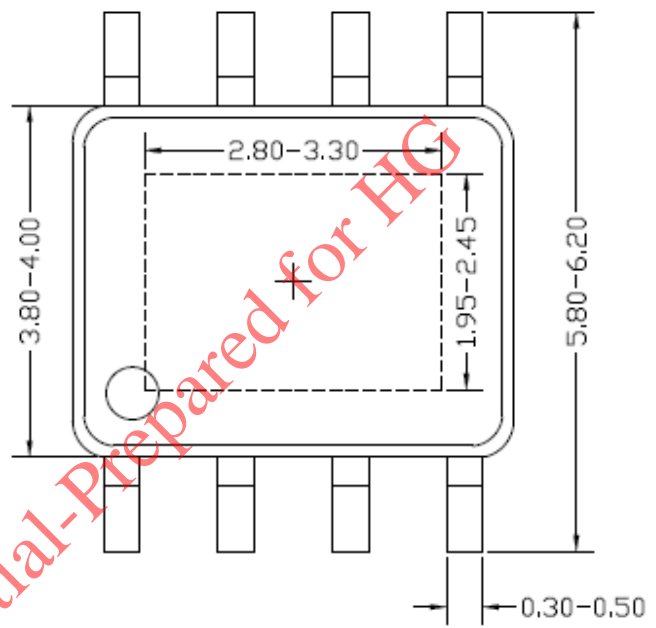

Top view

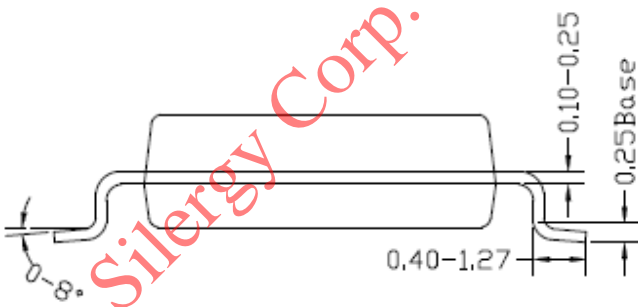

Side view

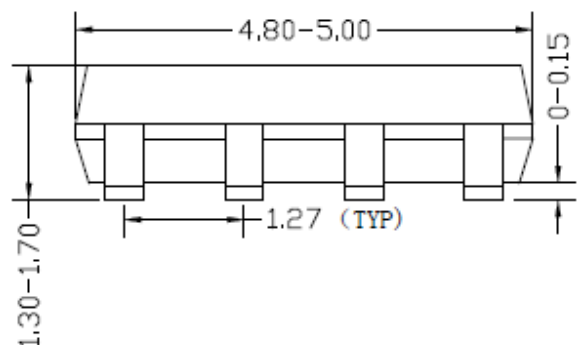

Front view

Notes: All dimension in millimeter and exclude mold flash & metal burr.

Taping & Reel Specification

1. SO8E taping orientation

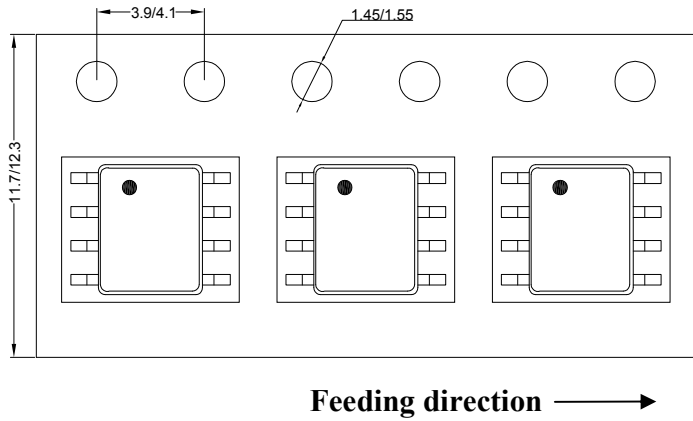

2. Carrier Tape & Reel specification for packages

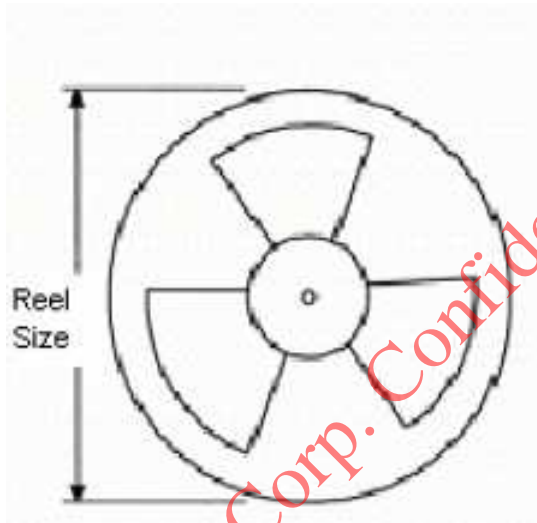

Package types	Tape width (mm)	Pocket pitch(mm)	Reel size (Inch)	Trailer length(mm)	Leader length (mm)	Qty per reel
SO8E	12	8	13"	400	400	2500

3. Others: NA