

Rockchip RK3588J Datasheet

Revision History

Date	Revision	Description
2023-08-03	1.1	Update the CPU frequency and pin information
2023-06-15	1.0	Initial release

Table of Content

Table of Content	2
Figure Index	3
Table Index.....	4
Warranty Disclaimer.....	5
Chapter 1 Introduction	6
1.1 Overview	6
1.2 Features	6
1.3 Block Diagram	16
Chapter 2 Package Information.....	17
2.1 Order Information	17
2.2 Top Marking	17
2.3 Package Dimension	17
2.4 MSL Information	19
2.5 Lead Finish/Ball Material Information	19
2.6 Pin Number List	20
Chapter 3 Electrical Specification	28
3.1 Absolute Ratings	28
3.2 Recommended Operating Conditions	29
3.3 DC Characteristics	31
3.4 Electrical Characteristics for General IO	31
3.5 Electrical Characteristics for PLL	32
3.6 Electrical Characteristics for PCIe2/SATA Interface	32
3.7 Electrical Characteristics for MIPI CDPHY interface	33
3.8 Electrical Characteristics for MIPI CSI DPHY interface	33
3.9 Electrical Characteristics for SARADC	33
3.10 Electrical Characteristics for TSADC.....	34
Chapter 4 Thermal Management.....	35
4.1 Overview	35
4.2 Package Thermal Characteristics	35

Figure Index

Fig.1-1 Block Diagram	16
Fig.2-1 Package Definition	17
Fig.2-2 Package Top View	17
Fig.2-3 Package Bottom View	18

Rockchip Confidential

Table Index

Table 2-1 Pin Number Order Information..... 20

Table 3-1 Absolute Ratings..... 28

Table 3-2 Recommended Operating Conditions..... 29

Table 3-3 DC Characteristics..... 31

Table 3-4 Electrical Characteristics for Digital General IO 31

Table 3-5 Electrical Characteristics for INT PLL..... 32

Table 3-6 Electrical Characteristics for FRAC PLL..... 32

Table 3-7 Electrical Characteristics for DDR PLL..... 32

Table 3-8 Electrical Characteristics for PCIe2/SATA Interface..... 32

Table 3-9 Electrical Characteristics for MIPI CDPHY interface..... 33

Table 3-101 Electrical Characteristics for SARADC..... 33

Table 4-1 Thermal Resistance Characteristics..... 35

Rockchip Confidential

Warranty Disclaimer

Copyright © 2023 Rockchip Electronics Co., Ltd. All rights reserved.

No part of this document may be reproduced, transmitted or used in any form or by any means without the written prior consent of Rockchip Electronics Co., Ltd.

Trademark

Rockchip is a registered trademark of Rockchip Electronics Co., Ltd. in the People's Republic of China and other countries/areas. Other brands, product names mentioned in this document are the property of their respective owners.

Disclaimer

Rockchip Electronics Co., Ltd. ("Rockchip") may make changes to any information in this document at any time without any prior notice.

Information in this document is provided just as a reference or typical applications. All or part of product features described in this document may not be within the purchase scope or the usage scope, and may be subject to the third party licensing requirements. All statements, information in this document is provided "AS IS" without warranties of any kind, either express or implied. Actual performance of Rockchip products may vary in different applications. Third party licenses maybe required to use some features supported by Rockchip products. Customers shall be solely and exclusively responsible to obtain all appropriately required third party licenses prior to its such use. Should customers use the features supported by Rockchip products without any required third party license, customers shall indemnify and hold Rockchip and its subsidiaries, affiliates as well as distributors harmless against all claims, costs, damages, and expenses, and reasonable attorney fees arising out of any claim associated with such unauthorized use.

Rockchip products are not intended for use in military, airplane, medical devices, lifesaving or life sustaining applications ("Unintended Uses"). Customers shall take any and all actions to ensure using Rockchip products in a lawful manner and shall be liable for Unintended Uses.

Chapter 1 Introduction

1.1 Overview

RK3588J is a low power, high performance processor for intelligent hardware and industrial applications.

Many embedded powerful hardware engines provide optimized performance for high-end application. RK3588J supports H.265 and VP9 decoder by 8K@60fps, H.264 decoder by 8K@30fps, and AV1 decoder by 4K@60fps, also support H.264 and H.265 encoder by 8K@30fps, high-quality JPEG encoder/decoder, specialized image preprocessor and postprocessor.

Embedded 3D GPU makes RK3588J completely compatible with OpenGL ES 1.1, 2.0, and 3.2, OpenCL up to 2.2 and Vulkan1.2. Special 2D hardware engine with MMU will maximize display performance and provide very smoothly operation.

RK3588J introduces a new generation totally hardware-based maximum 48-Megapixel ISP (image signal processor). It implements a lot of algorithm accelerators, such as HDR, 3A, LSC, 3DNR, 2DNR, sharpening, dehaze, fisheye correction, gamma correction and so on.

The build-in NPU supports INT4/INT8/INT16/FP16 hybrid operation and computing power is up to 6TOPs. In addition, with its strong compatibility, network models based on a series of frameworks such as TensorFlow/MXNet/PyTorch/Caffe can be easily converted.

RK3588J has high-performance quad channel external memory interface (LPDDR4/LPDDR4X/LPDDR5) capable of sustaining demanding memory bandwidths, also provides a complete set of peripheral interface to support very flexible applications.

1.2 Features

1.2.1 Microprocessor

- Quad-core ARM Cortex-A76 MPCore processor and quad-core ARM Cortex-A55 MPCore processor, both are high-performance, low-power and cached application processor
- DSU (DynamIQ Shared Unit) comprises the L3 memory system, control logic, and external interfaces to support a DynamIQ cluster
- Full implementation of the ARM architecture v8-A instruction set, ARM Neon Advanced SIMD (single instruction, multiple data) support for accelerating media and signal processing
- ARMv8 Cryptography Extensions
- Trustzone technology support
- Integrated 64KB L1 instruction cache, 64KB L1 data cache and 512KB L2 cache for each Cortex-A76
- Integrated 32KB L1 instruction cache, 32KB L1 data cache and 128KB L2 cache for each Cortex-A55
- Quad-core Cortex-A76 and Quad-core Cortex-A55 share 3MB L3 cache
- Eight separate power domains for CPU core system to support internal power switch and externally turn on/off based on different application scenario
 - PD_CPU_0: 1st Cortex-A55 + Neon + FPU + L1/L2 I/D Cache
 - PD_CPU_1: 2nd Cortex-A55 + Neon + FPU + L1/L2 I/D Cache
 - PD_CPU_2: 3rd Cortex-A55 + Neon + FPU + L1/L2 I/D Cache
 - PD_CPU_3: 4th Cortex-A55 + Neon + FPU + L1/L2 I/D Cache
 - PD_CPU_4: 1st Cortex-A76 + Neon + FPU + L1/L2 I/D Cache
 - PD_CPU_5: 2nd Cortex-A76 + Neon + FPU + L1/L2 I/D Cache
 - PD_CPU_6: 3rd Cortex-A76 + Neon + FPU + L1/L2 I/D Cache
 - PD_CPU_7: 4th Cortex-A76 + Neon + FPU + L1/L2 I/D Cache
- Three isolated voltage domains to support DVFS, one for A76_0 and A76_1, one for

A76_2 and A76_3, the other for DSU and Cortex-A55.

1.2.2 Memory Organization

- Internal on-chip memory
 - BootRom
 - ◆ Support system boot from the following device:
 - SPI interface
 - eMMC interface
 - SD/MMC interface
 - ◆ Support system code download by the following interface:
 - USB OTG interface
 - Share Memory in the voltage domain of VD_LOGIC
 - PMU SRAM in VD_PMU for low power application
- External off-chip memory
 - Dynamic Memory Interface
 - ◆ Compatible with JEDEC standards LPDDR4/LPDDR4X/LPDDR5
 - ◆ Support four channels, each channel 16bits data widths
 - ◆ Support up to 2 ranks (chip selects) for each channel
 - ◆ Totally up to 32GB address space
 - ◆ Low power modes, such as power-down and self-refresh for SDRAM
 - eMMC Interface
 - ◆ Fully compliant with JEDEC eMMC 5.1 and eMMC 5.0 specification
 - ◆ Backward compliant with eMMC 4.51 and earlier versions specification.
 - ◆ Support HS400, HS200, DDR50 and legacy operating modes
 - ◆ Support three data bus width: 1bit, 4bits or 8bits
 - SD/MMC Interface
 - ◆ Compatible with SD3.0, MMC ver4.51
 - ◆ Data bus width is 4bits
 - Flexible Serial Flash Interface(FSPI)
 - ◆ Support transfer data from/to serial flash device
 - ◆ Support 1bit, 2bits or 4bits data bus width
 - ◆ Support 2 chips select

1.2.3 System Component

- MCU
 - Three Cortex-M0 MCUs inside RK3588J
 - MCU in VD_PMU integrate 16KB Cache and 16KB TCM
 - MCU in VD_NPU integrate 16KB Cache and 64KB TCM
 - MCU in PD_CENTER integrate 32KB TCM
 - Integrated Programmable Interrupt Controller, all IRQ lines connected to GIC for CPU also connect to MCU in VD_PMU(PMU_M0) and PD_CENTER(DDR_M0)
 - Integrated Debug Controller with JTAG interface
- CRU (clock & reset unit)
 - Support total 18 PLLs to generate all clocks
 - One oscillator with 24MHz clock input
 - Support clock gating control for individual components
 - Support global soft-reset control for whole chip, also individual soft-reset for each component
- PMU (power management unit)
 - Multiple configurable work modes to save power by different frequency or automatic clock gating control or power domain on/off control
 - Lots of wakeup sources in different mode
 - Support 10 separate voltage domains
 - Support 45 separate power domains, which can be power up/down by software based on different application scenes
- Timer
 - Support 12 secure timers with 64bits counter and interrupt-based operation
 - Support 18 non-secure timers with 64bits counter and interrupt-based operation
 - Support two operation modes: free-running and user-defined count for each timer

- Support timer work state checkable
- PWM
 - Support 16 on-chip PWMs(PWM0~PWM15) with interrupt-based operation
 - Programmable pre-scaled operation to bus clock and then further scaled
 - Embedded 32-bit timer/counter facility
 - Support capture mode
 - Support continuous mode or one-shot mode
 - Provides reference mode and output various duty-cycle waveform
 - Optimized for IR application for PWM3, PWM7, PWM11, PWM15
- Watchdog
 - 32-bit watchdog counter
 - Counter counts down from a preset value to 0 to indicate the occurrence of a timeout
 - WDT can perform two types of operations when timeout occurs:
 - ◆ Generate a system reset
 - ◆ First generate an interrupt and if this is not cleared by the service routine by the time a second timeout occurs then generate a system reset
 - Totally five Watchdog for CPU and MCU
- Interrupt Controller
 - Support 12 PPI interrupt source and 480 SPI interrupt sources input from different components inside RK3588J
 - Support 16 software-triggered interrupts
 - Input interrupt level is fixed, high-level sensitive for SPI and low-level sensitive for PPI
 - Support different interrupt priority for each interrupt source, and they are always software-programmable
- DMAC
 - Micro-code programming based DMA
 - Linked list DMA function is supported to complete scatter-gather transfer
 - Support data transfer types including memory-to-memory, memory-to-peripherals, peripherals-to-memory
 - Totally three embedded DMA controllers for peripheral system
 - Each DMAC features:
 - ◆ Support 8 channels
 - ◆ 32 hardware request from peripherals
 - ◆ 2 interrupt output
 - ◆ Support TrustZone technology and programmable secure state for each DMA channel
- Secure System
 - Embedded two cipher engine
 - ◆ Support Link List Item (LLI) DMA transfer
 - ◆ Support SHA-1, SHA-256/224, SHA-512/384, MD5, SM3 with hardware padding
 - ◆ Support HMAC of SHA-1, SHA-256, SHA-512, MD5, SM3 with hardware padding
 - ◆ Support AES-128, AES-192, AES-256 encrypt & decrypt cipher
 - ◆ Support AES ECB/CBC/OFB/CFB/CTR/CTS/XTS/CCM/GCM/CBC-MAC/CMAC mode
 - ◆ Support SM4 ECB/CBC/OFB/CFB/CTR/CTS/XTS/CCM/GCM/CBC-MAC/CMAC mode
 - ◆ Support DES & TDES cipher, with ECB/CBC/OFB/CFB mode
 - ◆ Support up to 4096 bits PKA mathematical operations for RSA/ECC/SM2
 - ◆ Support generating random numbers
 - Support keyladder to guarantee key secure
 - Support data scrambling for all DDR types
 - Support secure OTP
 - Support secure debug
 - Support secure DFT test
 - Support secure OS

- Except CPU, the other masters in the SoC can also support security and non-security mode by software-programmable
- Some slave components in SoC can only be addressed by security master and the other slave components can be addressed by security master or non-security master by software-programmable
- System SRAM(share memory), part of space is addressed only in security mode
- External DDR space can be divided into 16 parts, each part can be software-programmable to be enabled by each master
- Mailbox
 - Three Mailbox in SoC to service CPU and MCU communication
 - Support four mailbox elements per mailbox, each element includes one data word, one command word register and one flag bit that can represent one interrupt
 - Provide 32 lock registers for software to use to indicate whether mailbox is occupied
- Decompression
 - Support for decompressing GZIP files
 - Support for decompressing LZ4 files, including the General Structure of LZ4 Frame format and the Legacy Frame format.
 - Support for decompressing data in DEFLATE format
 - Support for decompressing data in ZLIB format
 - Support Hash32 check in LZ4 decompression process
 - Support the limit size function of the decompressed data to prevent the memory from being maliciously destroyed during the decompression process

1.2.4 Video CODEC

- Video Decoder
 - Real-time video decoder of MPEG-1, MPEG-2, MPEG-4, H.263, H.264, H.265, VC-1, VP9, VP8, MVC, AV1
 - MMU Embedded
 - Multi-channel decoder in parallel for less resolution
 - H.264 AVC/MVC Main10 L6.0 : 8K@30fps (7680x4320)[®]
 - VP9 Profile0/2 L6.1 : 8K@60fps (7680x4320)
 - H.265 HEVC/MVC Main10 L6.1 : 8K@60fps (7680x4320)
 - AVS2 Profile0/2 L10.2.6 : 8K@60fps (7680x4320)
 - AV1 Main Profile 8/10bit L5.3 : 4K@60fps (3840x2160)
 - MPEG-2 up to MP : 1080p@60fps (1920x1088)
 - MPEG-1 up to MP : 1080p@60fps (1920x1088)
 - VC-1 up to AP level 3 : 1080p@60fps (1920x1088)
 - VP8 version2 : 1080p@60fps (1920x1088)
- Video Encoder
 - Real-time H.265/H.264 video encoding
 - Support up to 8K@30fps
 - Multi-channel encoder in parallel for less resolution

1.2.5 JPEG CODEC

- JPEG Encoder
 - Baseline (DCT sequential)
 - Encoder size is from 96x96 to 8192x8192(67Mpixels)
 - Up to 90 million pixels per second
 - Embedded four encoder units
- JPEG Decoder
 - Decoder size is from 48x48 to 65536x65536
 - Support YUV400/YUV411/YUV420/YUV422/YUV440/YUV444
 - Support up to 1080P@280fps, and 560 million pixels per second
 - Support MJPEG
 - Embedded four encoder units

1.2.6 Neural Process Unit

- Neural network acceleration engine with processing performance up to 6 TOPS
- Include triple NPU core, and support triple core co-work, dual core co-work, and work

independently

- Support integer 4, integer 8, integer 16, float 16, Bfloat 16 and tf32 operation
- Embedded 384KBx3 internal buffer
- Multi-task, multi-scenario in parallel
- Support deep learning frameworks: TensorFlow, Caffe, Tflite, Pytorch, Onnx NN, Android NN, etc.
- One isolated voltage domain to support DVFS

1.2.7 Graphics Engine

- 3D Graphics Engine
 - ARM Mali-G610 MP4
 - High performance OpenGL ES 1.1, 2.0 and 3.2, OpenCL 2.2, Vulkan1.2 etc.
 - Embedded 4 shader cores with shared hierarchical tiler
 - Provide MMU and L2 Cache with 4x 256KB size
 - The latest Valhall architecture
 - ARM Frame Buffer Compression(AFBC) 1.3
 - Support Serial Wire debug for embedded MCU
 - One isolated voltage domain to support DVFS
- 2D Graphics Engine
 - Source format: ARGB/RGB888/RGB565/YUV420/YUV422/BPP
 - Destination formats: ARGB/RGB888/RGB565/YUV420/YUV422
 - Max resolution: 8192x8192 source, 4096x4096 destination
 - Block transfer and Transparency mode
 - Color fill with gradient fill, and pattern fill
 - Alpha blending modes including global alpha, per pixel alpha (color/alpha channel separately) and fading
 - Arbitrary non-integer scaling ratio, from 1/8 to 8
 - 0, 90, 180, 270 degree rotation, x-mirror, y-mirror & rotation operation
 - ROP2, ROP3, ROP4
 - Support 4k/64k page size MMU
- Image Enhancement Processor
 - Image format
 - ◆ Input data: YUV420/YUV422, semi-planar/planar, UV swap
 - ◆ Output data: YUV420/YUV422, semi-planar, UV swap, Tile mode
 - ◆ YUV down sampling conversion from 422 to 420
 - ◆ Max resolution for dynamic image up to 1920x1080
 - De-interlace

1.2.8 Video Input Interface

- MIPI interface
 - Two MIPI DC(DPHY/CPHY) combo PHY
 - ◆ Support to use DPHY or CPHY
 - ◆ Each MIPI DPHY V1.2, 4lanes, 2.5Gbps per lane
 - ◆ Each MIPI CPHY V1.1, 3lanes, 2.5Gsps per lane
 - Four MIPI CSI DPHY
 - ◆ Each MIPI DPHY V1.2, 2lanes, 2.5Gbps per lane
 - ◆ Support to combine 2 DPHY together to one 4lanes
 - Support camera input combination:
 - ◆ 2 MIPI DCPHY + 4 MIPI CSI DPHY(2 lanes), totally support 6 cameras input
 - ◆ 2 MIPI DCPHY + 1 MIPI CSI DPHY(4 lanes) + 2 MIPI CSI DPHY(2 lanes), totally support 5 cameras input
 - ◆ 2 MIPI DCPHY + 2 MIPI CSI DPHY(4 lanes), totally support 4 cameras input
- DVP interface
 - One 8/10/12/16-bit standard DVP interface, up to 150MHz input data
 - Support BT.601/BT.656 and BT.1120 VI interface
 - Support the polarity of pixel_clk, hsync, vsync configurable
- HDMI RX interface
 - Single-port HDMI 2.0 RX PHY, 4 lanes, no sideband channels
 - Data rate support in HDMI 2.0 mode

- 6Gbps down to 3.4Gbps
- Data rate support in HDMI 1.4 mode
 - ◆ 3.4Gbps down to 250Mbps
- HDMI 2.0 video formats
 - ◆ TMDS Scrambler to enable support for 2160p@60 Hz with RGB/YCbCr4:4:4 or YCbCr4:2:2
 - ◆ Supports YCbCr 4:2:0 to enable 2160p@60Hz at lower HDMI link speeds
- HDMI 1.4b video formats
 - ◆ All CEA-861-E video formats up to 1080p@120Hz
 - ◆ HDMI 1.4b 4K x 2K video formats(3840x2160p@24Hz/25Hz/30Hz and 4096x2160p@24Hz)
 - ◆ HDMI 1.4b 3D video modes with up to 340 MHz(TMDS clock)
- Support HDCP2.3 and HDCP1.4

1.2.9 Image Signal Processor

- Video Capture(VICAP)
 - Support BT601, BT656, BT1120
 - Support receiving six interfaces of MIPI CSI/DSI, up to four IDs for each interface
 - Support five CSI data formats: RAW8/10/12/14, YUV422
 - Support three modes of HDR: virtual channel mode, identification code mode, line counter mode
 - Support RAW data through to ISP0/1
- Maximum input
 - 48M: 8064x6048@15 dual ISP
 - 32M: 6528x4898@30 dual ISP
 - 16M: 4672x3504@30 single ISP
- 3A: include AE/Histogram, AF, AWB statistics output
- FPN: Fixed Pattern Noise removal
- BLC: Black Level Correction
- DPCC: Static/Dynamic defect pixel cluster correction
- PDAF: Phase Detection Auto Focus
- LSC: Lens shading correction
- Bayer-2DNR: Spatial Bayer-raw De-noising
- Bayer-3DNR: Temporal Bayer-raw De-noising
- CAC: Chromatic Aberration Correction
- HDR: 3-Frame Merge into High-Dynamic Range
- DRC: HDR Dynamic Range Compression, Tone mapping
- GIC: Green Imbalance Correction
- Debayer: Advanced Adaptive Demosaic with Chromatic Aberration Correction
- CCM/CSM: Color correction matrix; RGB2YUV etc
- Gamma: Gamma out correction
- Dehaze/Enhance: Automatic Dehaze and Effect enhancement
- 3DLUT: 3D-Lut Color Palette for Customer
- LDCH: Lens-distortion only in the horizontal direction
- YUV-2DNR: Spatial YUV De-noising
- Sharp: Image Sharpening and boundary filtering
- CMSK: privacy mask
- GAIN: image local gain
- Support multi-sensor reuse ISP
- FishEye Correction(FEC)
 - Input mode and data format
 - ◆ Support RASTER: YUV422SP, YUV422I, YUV420SP
 - Output mode and data format
 - ◆ RASTER: YUV422SP, YUV422I, YUV420SP
 - ◆ FBCE: YUV422SP, YUV420SP
 - Support 16x8, 32x16 two density
 - Support up to 4 times reduction factor
 - Resolution 128x128~4095x4095

- Y Interpolation: Bicubic; C Interpolation: Biliner

1.2.10 Display interface

- HDMI/eDP TX interface
 - Support two HDMI/eDP TX combo interface, but HDMI and eDP cannot work at the same time for each interface
 - Support x1, x2 and x4 configuration for each interface
 - Support all the data rates for HDMI FRL: 3, 6, 8, 10 and 12Gbps
 - Support 1.62Gbps, 2.7Gbps and 5.4Gbps for eDP
 - Support up to 7680x4320@60Hz for HDMI TX, and 4K@60Hz for eDP
 - Support RGB/YUV(up to 10bit) format for HDMI TX
 - Support RGB, YCbCr 4:4:4, YCbCr 4:2:2 and 8/10 bit per component video format for eDP
 - Support DSC 1.2a for HDMI TX
 - Support HDCP2.3 for HDMI TX, and HDCP1.3 for eDP
- DP TX interface
 - Support 2 DP TX 1.4a interface which combo with USB3.1 Gen1
 - Support 1/2/4lanes for each interface
 - Support 1.62Gbps, 2.7Gbps, 5.4Gbps and 8.1Gbps Serializer
 - Support up to 8192x4320@30Hz
 - Support RGB/YUV(up to 10bit) format
 - Support Single Stream Transport(SST)
 - Support DP Alt mode on USB Type-C
 - Support HDCP2.3, HDCP 1.3
- MIPI DSI interface
 - Support 2 MIPI DPHY 2.0 interface
 - Support 4 data lanes and 4.5Gbps maximum data rate per lane
 - Support max resolution 4K@60Hz
 - Support dual MIPI display: left-right mode
 - Support RGB(up to 10bit) format
 - Support DSC 1.1/1.2a
- BT.1120 video output interface
 - Support up to 1920x1080@60Hz
 - Support RGB(up to 8bit) format
 - Up to 150MHz data rate

1.2.11 Video Output Processor

- Video ports
 - Video Port0, max output resolution: 7680x4320@60Hz
 - Video Port1, max output resolution: 4096x2304@60Hz
 - Video Port2, max output resolution: 4096x2304@60Hz
 - Video Port3, max output resolution: 1920x1080@60Hz
- Cluster 0/1/2/3
 - Max input and output resolution 4096x2304
 - Support AFBCD
 - Support RGB/YUV/YUYV format
 - Support scale up/down ratio 4~1/4
 - Support rotation
- ESMART 0/1/2/3
 - Max input and output resolution 4096x2304
 - Support RGB/YUV/YUYV format
 - Support scale up/down ratio 8~1/8
 - Support 4 region
- Overlay
 - Support up to 8 layers overlay: 4 cluster/4 esmart
 - Support RGB/YUV domain overlay
- Post process
 - HDR
 - ◆ HDR10/HDR HLG

- ◆ HDR2SDR/SDR2HDR
- 3D-LUT/P2I/CSC/BCSH/DITHER/CABC/GAMMA/COLORBAR
- Write back
 - Format: ARGB8888/RGB888/RGB565/YUV420
 - Max resolution: 1920x1080

1.2.12 Audio Interface

- I2S0/I2S1 with 8 channels
 - Up to 8 channels TX and 8 channels RX path
 - Audio resolution from 16bits to 32bits
 - Sample rate up to 192KHz
 - Provides master and slave work mode, software configurable
 - Support 3 I2S formats (normal, left-justified, right-justified)
 - Support 4 PCM formats (early, late1, late2, late3)
 - Support TDM normal, 1/2 cycle left shift, 1 cycle left shift, 2 cycle left shift, right shift mode serial audio data transfer
 - I2S, PCM and TDM mode cannot be used at the same time
- I2S2/I2S3 with 2 channels
 - Up to 2 channels for TX and 2 channels RX path
 - Audio resolution from 16bits to 32bits
 - Sample rate up to 192KHz
 - Provides master and slave work mode, software configurable
 - Support 3 I2S formats (normal, left-justified, right-justified)
 - Support 4 PCM formats (early, late1, late2, late3)
 - I2S and PCM cannot be used at the same time
- SPDIF0/SPDIF1
 - Support two 16-bit audio data store together in one 32-bit wide location
 - Support biphase format stereo audio data output
 - Support 16 to 31 bit audio data left or right justified in 32-bit wide sample data buffer
 - Support 16, 20, 24 bits audio data transfer in linear PCM mode
 - Support non-linear PCM transfer
- PDM0/PDM1
 - Up to 8 channels
 - Audio resolution from 16bits to 24bits
 - Sample rate up to 192KHz
 - Support PDM master receive mode
- Digital Audio Codec
 - Support 2 channels digital DAC
 - Support I2S/PCM interface, master and slave mode
 - Support 16 bit sample resolution
 - Support three modes of mixing for every digital DAC channel
 - Support volume control
- VAD(Voice Activity Detection)
 - Support read voice data from I2S/PDM
 - Support voice amplitude detection
 - Support Multi-Mic array data storing
 - Support a level combined interrupt

1.2.13 Connectivity

- SDIO interface
 - Compatible with SDIO3.0 protocol
 - 4-bit data bus widths
- GMAC 10/100/1000M Ethernet controller
 - Support two Ethernet controllers
 - Support 10/100/1000-Mbps data transfer rates with the RGMII interfaces
 - Support 10/100-Mbps data transfer rates with the RMII interfaces
 - Support both full-duplex and half-duplex operation
- USB3.1 Gen1

- Support USB3.1 Gen1, equal to USB3.2 Gen1 and USB3.0, up to 5Gbps datarate
- Embedded 2 USB3.1 OTG interfaces which combo with DP TX (USB3OTG_0 and USB3OTG_1)
- Embedded 1 USB3.1 Host interface which combo with Combo PIPE PHY2 (USB3OTG_2)
- Compatible Specification
 - ◆ Universal Serial Bus 3.0 Specification, Revision 1.0
 - ◆ Universal Serial Bus Specification, Revision 2.0 (exclude USB3OTG_2)
 - ◆ eXtensible Host Controller Interface for Universal Serial Bus (xHCI), Revision 1.1
- Support Control/Bulk (including stream)/Interrupt/Isochronous Transfer
- Simultaneous IN and OUT transfer for USB3.1 Gen1
- Descriptor caching and data pre-fetching used to improve system performance in high-latency systems
- LPM protocol in USB 2.0 (exclude USB3OTG_2) and U0, U1, U2, and U3 states for USB3.1 Gen1
- USB3.1 Gen1 Device Features
 - ◆ Up to 10 IN endpoints, including control endpoint 0
 - ◆ Up to 6 OUT endpoints, including control endpoint 0
 - ◆ Up to 16 endpoint transfer resources, each one for each endpoint
 - ◆ Flexible endpoint configuration for multiple applications/USB set-configuration modes
 - ◆ Hardware handles ERDY and burst
 - ◆ Stream-based bulk endpoints with controller automatically initiating data movement
 - ◆ Isochronous endpoints with isochronous data in data buffers
 - ◆ Flexible Descriptor with rich set of features to support buffer interrupt moderation, multiple transfers, isochronous, control, and scattered buffering support
- USB3.1 Gen1 xHCI Host Features
 - ◆ Support up to 64 devices
 - ◆ Support 1 interrupter
 - ◆ Support 1 USB2.0 port (exclude USB3OTG_2) and 1 Super-Speed port
 - ◆ Support standard or open-source xHCI and class driver
- USB3.1 Gen1 Dual-Role Device (DRD) Features
 - ◆ Static Device Operation
 - ◆ Static Host Operation
 - ◆ USB3.1/USB2.0 OTG A device and B device basing on ID, USB3OTG_2 only support USB3.1 Gen1
 - ◆ Not Support USB3.1/USB2.0 OTG session request protocol (SRP), host negotiation protocol (HNP) and Role Swap Protocol (RSP)
- Miscellaneous Features
 - ◆ USB2.0 PHY support Battery Charge detection
 - ◆ USB3OTG_0 and USB3OTG_1 support USB Type-C and DP Alt Mode
 - ◆ USB3OTG_2 PHY combos with PCIE and SATA
- USB 2.0 Host
 - Compatible with USB 2.0 specification
 - Support two USB 2.0 Host
 - Supports high-speed(480Mbps), full-speed(12Mbps) and low-speed(1.5Mbps) mode
 - Support Enhanced Host Controller Interface Specification (EHCI), Revision 1.0
 - Support Open Host Controller Interface Specification (OHCI), Revision 1.0a
- Combo PIPE PHY Interface
 - Support three Combo PIPE PHYs with PCIE2.1/SATA3.0/USB3.1 controller
 - Combo PIPE PHY0 support one of the following interfaces
 - ◆ SATA
 - ◆ PCIE2.1
 - Combo PIPE PHY1 support one of the following interfaces

- ◆ SATA
- ◆ PCIe2.1
- Combo PIPE PHY2 support one of the following interfaces
 - ◆ SATA
 - ◆ PCIe2.1
 - ◆ USB3.1 Gen1
- PCIe2.1 Interface
 - ◆ Compatible with PCI Express Base Specification Revision 2.1
 - ◆ Support 1 lane for each PCIe2.1 interface
 - ◆ Support Root Complex(RC) only
 - ◆ Support 5Gbps data rate
- SATA Interface
 - ◆ Compatible with Serial ATA 3.1 and AHCI revision 1.3.1
 - ◆ Support eSATA
 - ◆ Support 1 port for each SATA interface
 - ◆ Support 6Gbps data rate
- PCIe3.0 Interface
 - Compatible with PCI Express Base Specification Revision 3.0
 - Support dual operation mode: Root Complex(RC) and End Point(EP)
 - Support data rates: 2.5Gbps(PCIe1.1), 5Gbps(PCIe2.1), 8Gbps(PCIe3.0)
 - Support aggregation and bifurcation with 1x 4lanes, 2x 2lanes, 4x 1lanes and 1x 2lanes + 2x 1lanes
- SPI interface
 - Support 5 SPI Controllers(SPI0-SPI4)
 - Support two chip-select output
 - Support serial-master and serial-slave mode, software-configurable
- I2C Master controller
 - Support 9 I2C Master(I2C0-I2C8)
 - Support 7bits and 10bits address mode
 - Software programmable clock frequency
 - Data on the I2C-bus can be transferred at rates of up to 100k bits/s in the Standard-mode, up to 400k bits/s in the Fast-mode
- UART interface
 - Support 10 UART interfaces(UART0-UART9)
 - Embedded two 64-byte FIFO for TX and RX operation respectively
 - Support 5bit, 6bit, 7bit, 8bit serial data transmit or receive
 - Standard asynchronous communication bits such as start, stop and parity
 - Support different input clock for UART operation to get up to 4Mbps baud rate
 - Support auto flow control mode for all UART

1.2.14 Others

- Multiple group of GPIO
 - All of GPIOs can be used to generate interrupt
 - Support level trigger and edge trigger interrupt
 - Support configurable polarity of level trigger interrupt
 - Support configurable rising edge, falling edge and both edge trigger interrupt
 - Support configurable pull direction(a weak pull-up and a weak pull-down)
 - Support configurable drive strength
- Temperature Sensor (TS-ADC)
 - Support User-Defined Mode and Automatic Mode
 - In User-Defined Mode, start_of_conversion can be controlled completely by software, and also can be generated by hardware.
 - In Automatic Mode, the temperature of alarm(high/low temperature) interrupt can be configurable
 - In Automatic Mode, the temperature of system reset can be configurable
 - Support to 7 channel TS-ADC, the temperature criteria of each channel can be configurable
 - -40~125°C temperature range and 1°C temperature resolution

- Successive approximation ADC (SARADC)
 - 12-bit resolution
 - Up to 1MS/s sampling rate
 - 8 single-ended input channels
- OTP
 - Support 32Kbit space and higher 4k address space is non-secure part.
 - Support read and program word mask in secure model
 - Support maximum 32 bit OTP program operation
 - Support maximum 16 word OTP read operation
 - Program and Read state can be read
 - Program fail address record
- Package Type
 - FCBGA1088L (body: 23mm x 23mm; ball size: 0.36mm; ball pitch: 0.65mm)

1.3 Block Diagram

The following figure shows the basic block diagram.

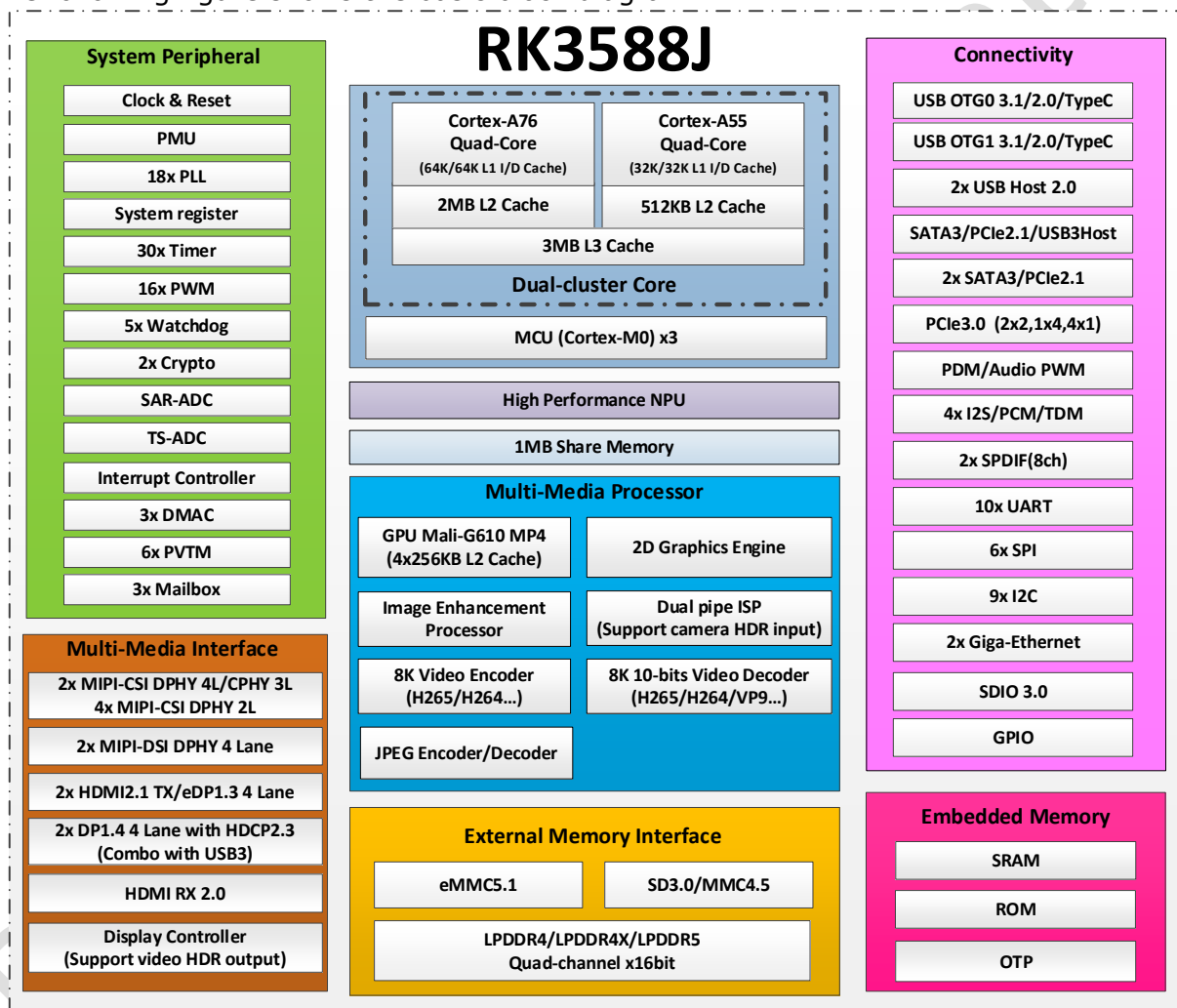

Fig.1-1 Block Diagram

Chapter 2 Package Information

2.1 Order Information

Orderable Device	RoHS status	Package	Package QTY	Device Feature
RK3588J	RoHS	FCBGA1088L	600PCS by tray	Application processor

2.2 Top Marking

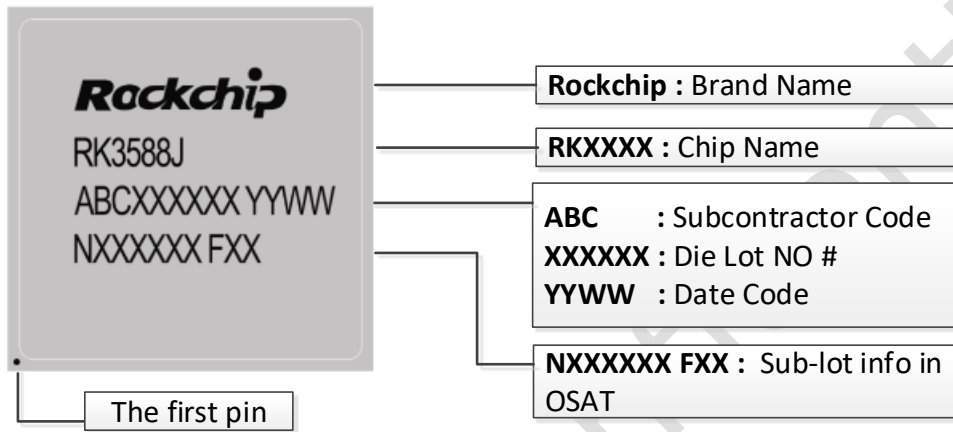

Fig.2-1 Package definition

2.3 Package Dimension

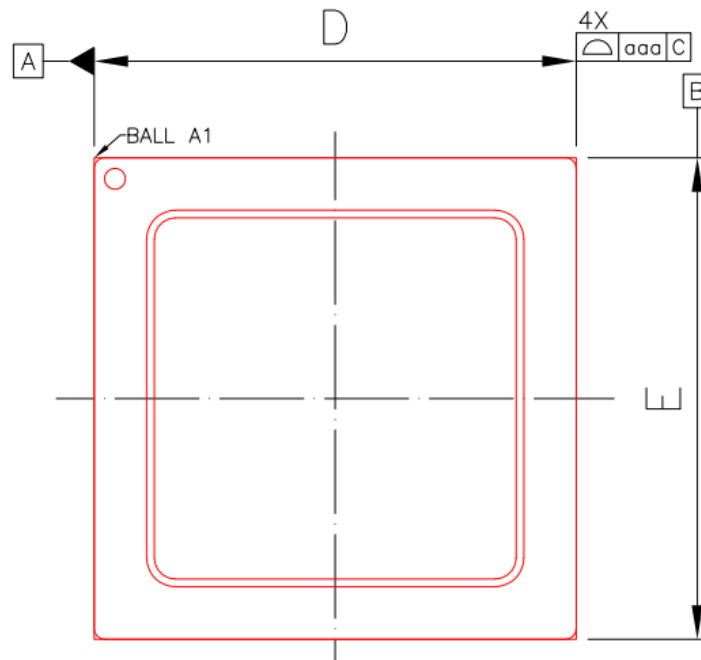

Fig.2-2 Package Top View

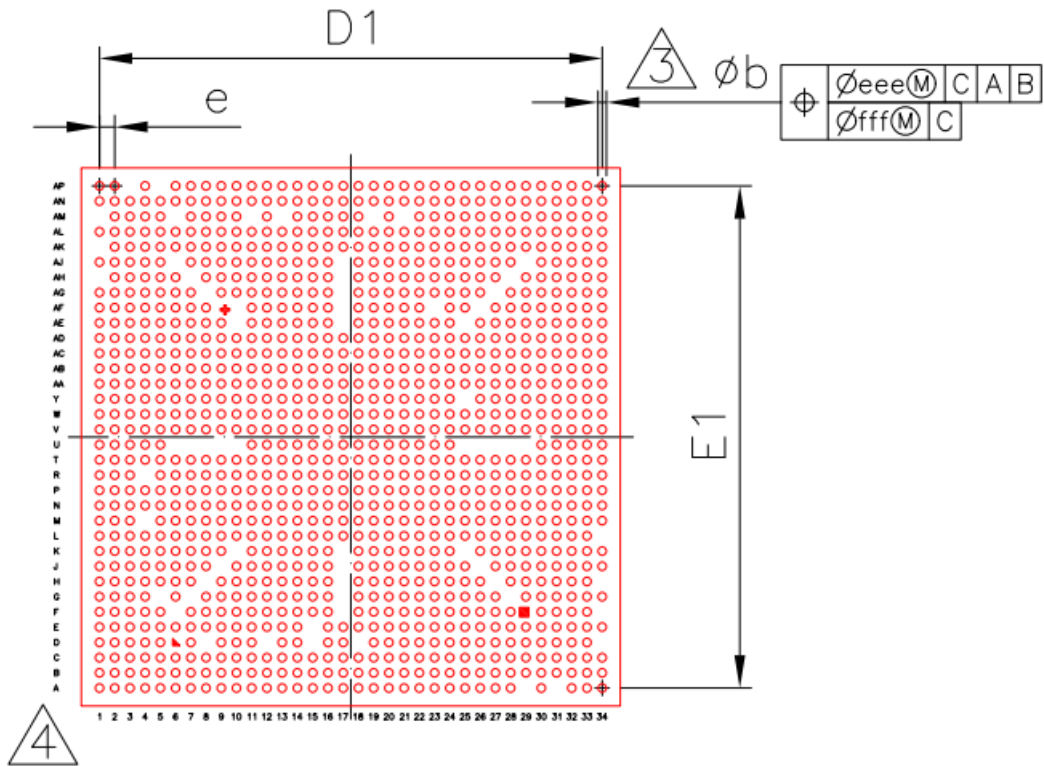

Fig.2-3 Package Bottom View

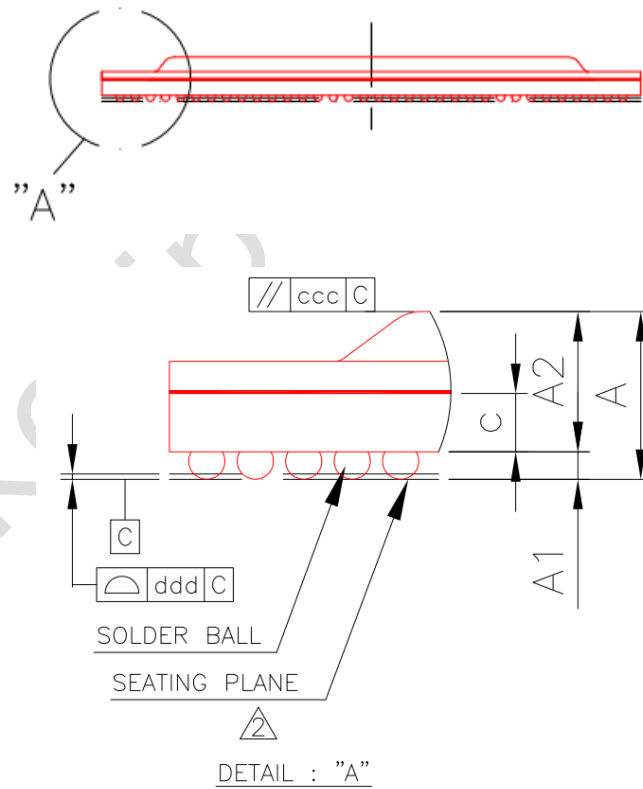

Fig.2-4 Package Side View

Symb ol	Dimension in mm			Dimension in inch		
	MIN	NOM	MAX	MIN	NOM	MAX
A	1.727	1.885	2.043	0.068	0.074	0.080
A1	0.20	0.25	0.30	0.008	0.010	0.012
A2	1.485	1.635	1.785	0.058	0.064	0.070
c	0.56	0.66	0.76	0.022	0.026	0.030
D	22.80	23.00	23.20	0.898	0.906	0.913
E	22.80	23.00	23.20	0.898	0.906	0.913
D1	---	21.45	---	---	0.844	---
E1	---	21.45	---	---	0.844	---
e	---	0.65	---	---	0.026	---
b	0.31	0.36	0.41	0.012	0.014	0.016
aaa	0.20			0.008		
ccc	0.35			0.014		
ddd	0.15			0.006		
eee	0.20			0.008		
fff	0.08			0.003		
MD/ME	34/34					

Fig.2-5 Package Dimension

2.4 MSL Information

Moisture sensitivity level: MSL3

2.5 Lead Finish/Ball Material Information

Lead Finish/Ball material: SnAgCu

2.6 Pin Number List

Table 2-1 Pin Number Order Information

Pin Name	Pin	Pin Name	Pin
VSS_1	A1	VSS_12	C5
DDR_CH1_DQ10_C	A2	VSS_13	C6
DDR_CH1_DQ8_C	A3	VSS_14	C7
DDR_CH1_DQ14_C	A4	VSS_15	C8
DDR_CH1_DQ12_C	A5	VSS_16	C9
DDR_CH1_DQ4_C	A6	DDR_CH0_DQ15_B	D1
DDR_CH1_DQ6_C	A7	DDR_CH0_DQ8_B	D2
DDR_CH1_DQ0_C	A8	VSS_34	D3
DDR_CH1_DQ2_C	A9	DDR_CH1_DM1_C	D4
DDR_CH1_A4_C	A10	DDR_CH1_DQS1N_C	D5
VSS_2	A11	DDR_CH1_WCK1P_C	D7
DDR_CH1_CKB_C	A12	DDR_CH1_DQS0N_C	D9
DDR_CH1_CKB_D	A13	DDR_CH1_A6_C	D10
VSS_3	A14	DDR_CH1_LP4/4X_CKE0/LP5_CS0_C	D11
DDR_CH1_A4_D	A15	DDR_CH1_A3_C	D13
DDR_CH1_DQ2_D	A16	DDR_CH1_A6_D	D14
DDR_CH1_DQ0_D	A17	DDR_CH1_LP4/4X_CKE0/LP5_CS0_D	D16
DDR_CH1_DQ6_D	A18	DDR_CH1_WCK0N_D	D17
DDR_CH1_DQ4_D	A19	DDR_CH1_LP4/4X_CS1_D	D19
DDR_CH1_DQ12_D	A20	DDR_CH1_DM0_D	D20
DDR_CH1_DQ14_D	A21	DDR_CH1_DQS1P_D	D21
DDR_CH1_DQ8_D	A22	DDR_CH1_DM1_D	D22
DDR_CH1_DQ10_D	A23	VSS_35	D23
PCIE30X1_1_CLKREQN_M2/DP0_HPDIN_M2/I2C2_SDA_M4/UART6_RX_M1/SPI4_MISO_M2/GPIO1_A0_d	A24	VSS_36	D24
PCIE30X1_1_WAKEN_M2/DP1_HPDIN_M2/SATA1_ACT_LED_M1/I2C2_SCL_M4/UART6_TX_M1/SPI4_MOSI_M2/GPIO1_A1_d	A25	PDM1_SDI2_M1/PCIE30X4_WAKEN_M3/SPI0_MISO_M2/GPIO1_B1_d	D25
VOP_POST_EMPTY/I2C4_SDA_M3/UART6_RTSN_M1/PWM0_M2/SPI4_CLK_M2/GPIO1_A2_d	A26	PDM1_SDI3_M1/PCIE30X4_PERSTN_M3/UART4_RX_M2/SPI0_MOSI_M2/GPIO1_B2_d	D26
HDMI_TX1_SDA_M2/I2C4_SCL_M3/UART6_CTSN_M1/PWM1_M2/SPI4_CS0_M2/GPIO1_A3_d	A27	PDM1_CLK1_M1/PCIE30X1_0_WAKEN_M2/SATA0_ACT_LED_M1/UART4_TX_M2/SPI0_CLK_M2/GPIO1_B3_d	D27
PCIE30_PORT1_REF_CLKP	A28	I2S0_SDI0/GPIO1_D4_d	D28
PCIE30_PORT1_TX0N	A30	PDM0_CLK0_M0/I2C4_SDA_M4/PWM15_IR_M2/GPIO1_C6_d	D29
PCIE30_PORT1_RX0N	A32	I2S0_LRCK/I2C2_SCL_M3/UART4_RTSN/GPIO1_C5_d	D30
PCIE30_PORT1_RESREF	A33	VSS_37	D31
VSS_4	A34	PCIE30_PORT0_TX0P	D32
DDR_CH0_DQ14_A	AA1	PCIE30_PORT0_TX0N	D33
DDR_CH0_DQ15_A	AA2	DDR_CH0_DQ13_B	E1
VSS_248	AA3	DDR_CH0_DQ14_B	E2
DDR_CH0_DQS1N_A	AA4	VSS_38	E3
DDR_CH0_DQS1P_A	AA5	DDR_CH0_DM1_B	E4
VSS_249	AA6	DDR_CH1_DQS1P_C	E5
VCCIO2_1V8	AA7	VSS_39	E6
AVSS_15	AA8	DDR_CH1_WCK1N_C	E7
HDMI/eDP_TX0_VDD_0V75	AA9	VSS_40	E8
AVSS_16	AA10	DDR_CH1_DQS0P_C	E9
VSS_250	AA11	DDR_CH1_RESET_C	E10
VDD_GPU_MEM_0	AA12	DDR_CH1_LP4/4X_CKE1/LP5_CS1_C	E11
VDD_GPU_0	AA13	VSS_41	E12
VDD_GPU_7	AA14	DDR_CH1_A2_C	E13
VDD_GPU_11	AA15	DDR_CH1_A3_D	E14
VSS_251	AA16	DDR_CH1_LP4/4X_CKE1/LP5_CS1_D	E16
VSS_252	AA17	DDR_CH1_WCK0P_D	E17
VSS_253	AA18	VSS_42	E18
VSS_254	AA19	DDR_CH1_LP4/4X_CS0_D	E19
VSS_255	AA20	VSS_43	E20
VSS_256	AA21	DDR_CH1_DQS1N_D	E21
VSS_257	AA22	VSS_44	E22
VSS_258	AA23	VSS_45	E23
VSS_259	AA24	PDM1_CLK0_M1/PCIE30X1_0_PERSTN_M2/UART7_RX_M2/SPI0_CS0_M2/GPIO1_B4_u	E24
MIPI_CS11_AVCC0V75	AA25	PCIE30X1_0_CLKREQN_M2/UART7_TX_M2/SPI0_CS1_M2/GPIO1_B5_u	E25
MIPI_CS11_AVCC1V8	AA26	MIPI_CAMERA1_CLK_M0/SPDIF0_TX_M0/PCIE30X2_WAKEN_M3/HDMI_RX_HPDIN_M2/I2C5_SCL_M3/UART1_TX_M1/GPIO1_B6_d	E26
HDMI_TX0_HPD_M1/PCIE30X2_PERSTN_M2/HDMI_RX_HPDIN_M1/MCU_JTAG_TCK_M1/UART9_RX_M2/SPI0_CS0_M3/GPIO3_D4_d	AA27	MIPI_CAMERA2_CLK_M0/SPDIF1_TX_M0/PCIE30X2_PERSTN_M3/HDMI_RX_CEC_M2/SATA2_ACT_LED_M1/I2C5_SDA_M3/UART1_RX_M1/PWM13_M2/GPIO1_B7_u	E27
GMAC1_PTP_REF_CLK/HDMI_TX1_HPD_M1/I2C3_SCL_M1/SPI1_MOSI_M1/GPIO3_B7_d	AA28	I2S0_SDI1/PDM0_SDI3_M0/I2C1_SDA_M4/UART4_RX_M0/PWM1_M1/SPI1_CS0_M2/GPIO1_D3_d	E28
GMAC1_TXD2/SDIO_D0_M1/I2S3_MCLK/FSPI_D0_M2/I2C6_SDA_M4/PWM10_M0/SPI4_MISO_M1/GPIO3_A0_u	AA29	I2S0_SDO0/I2C4_SCL_M4/UART4_CTSN/GPIO1_C7_d	E29
GMAC1_TXD3/SDIO_D1_M1/I2S3_SCLK/AUDDSM_LN/FSPI_D1_M2/I2C6_SCL_M4/PWM11_IR_M0/SPI4_MOSI_M1/GPIO3_A1_u	AA30	PDM0_CLK1_M0/I2C2_SDA_M3/PWM11_IR_M2/SPI4_CS1_M0/GPIO1_C4_d	E30
VSS_260	AA31	I2S0_SCLK/I2C6_SCL_M1/UART3_CTSN/PWM7_IR_M2/SPI4_CS0_M0/GPIO1_C3_d	E31
EMMC_D5/I2C1_SDA_M3/UART5_TX_M2/GPIO2_D5_u	AA32	VSS_46	E32
EMMC_D3/FSPI_D3_M0/GPIO2_D3_u	AA33	PCIE30_PORT0_REF_CLKP	E33
EMMC_RSTN/I2C2_SCL_M2/UART5_RTSN_M1/GPIO2_A3_d	AA34	PCIE30_PORT0_REF_CLKN	E34
DDR_CH0_DQ9_A	AB1	DDR_CH0_DQ4_B	F1
DDR_CH0_DQ8_A	AB2	DDR_CH0_DQ12_B	F2
VSS_261	AB3	VSS_47	F3

Pin Name	Pin	Pin Name	Pin
DDR_CH0_DM1_A	AB4	DDR_CH0_DQS1N_B	F4
VSS_262	AB5	DDR_CH0_DQS1P_B	F5
AVSS_17	AB6	VSS_48	F7
AVSS_18	AB7	DDR_CH1_DM0_C	F8
AVSS_19	AB8	VSS_49	F9
HDMI/eDP_TX0_AVDD_0V75	AB9	VSS_50	F10
AVSS_20	AB10	VSS_51	F11
VSS_263	AB11	DDR_CH1_A1_C	F12
VDD_GPU_MEM_1	AB12	VSS_52	F13
VDD_GPU_1	AB13	VSS_53	F14
VDD_GPU_6	AB14	VSS_54	F15
VDD_GPU_10	AB15	VSS_55	F16
VSS_264	AB16	DDR_CH1_ZQ_D	F18
VSS_265	AB17	VSS_56	F19
VSS_266	AB18	VSS_57	F20
VSS_267	AB19	VSS_58	F21
VSS_268	AB20	VSS_59	F22
VDD_NPU_6	AB21	VSS_60	F23
VDD_NPU_5	AB22	MIPI_CAMERA3_CLK_M0/HDMI_RX_SCL_M2/I2C8_SCL_M2/UART1_RTSN_M1/PWM14_M2/GPIO1_D6_u	F24
VDD_NPU_2	AB23	MIPI_CAMERA4_CLK_M0/PCIE30X2_CLKREQN_M3/HDMI_RX_SDA_M2/I2C8_SDA_M2/UART1_CTSN_M1/PWM15_IR_M3/GPIO1_D7_u	F25
VSS_269	AB24	I2S0_SDO1/I2C7_SCL_M0/UART6_TX_M2/SPI1_MISO_M2/GPIO1_D0_d	F26
MIPI_CS10_AVCC0V75	AB25	I2S0_SDO2/I2S0_SDI3/PDM0_SDI1_M0/I2C7_SDA_M0/UART6_RX_M2/SPI1_MOSI_M2/GPIO1_D1_d	F27
MIPI_CS10_AVCC1V8	AB26	I2S0_SDO3/I2S0_SDI2/PDM0_SDI2_M0/I2C1_SCL_M4/UART4_TX_M0/PWM0_M1/SPI1_CLK_M2/GPIO1_D2_d	F28
VSS_270	AB27	I2S0_MCLK/I2C6_SDA_M1/UART3_RTSN/PWM3_IR_M2/SPI4_CLK_M0/GPIO1_C2_d	F30
PCIE30X4_BUTTON_RSTN/DP1_HPDPIN_M0/MCU_JTAG_TMS_M1/UART9_TX_M2/PWM11_IR_M3/SPI0_CS1_M3/GPIO3_D5_d	AB28	VSS_61	F31
VSS_271	AB29	PCIE30_PORT0_RX1P	F32
GMAC0_PPSTRING/FSPI_CS1N_M1/HDMI_TX1_SCL_M0/I2C4_SCL_M1/UART7_TX_M0/GPIO2_B5_u	AB30	PCIE30_PORT0_RX1N	F33
GMAC0_PTP_REFCLK/FSPI_CS0N_M1/HDMI_TX1_SDA_M0/I2C4_SDA_M1/UART7_RX_M0/GPIO2_B4_u	AB31	DDR_CH0_DQ6_B	G1
VSS_272	AB32	DDR_CH0_DQ5_B	G2
GMAC0_MDIO/I2C0_SCL_M1/UART9_CTSN_M0/PWM6_M2/SPI3_MOSI_M0/GPIO4_C5_d	AB33	VSS_62	G3
GMAC0_MDC/I2C7_SDA_M1/UART9_RTSN_M0/PWM5_M2/SPI3_MISO_M0/GPIO4_C4_d	AB34	DDR_CH0_DM0_B	G4
DDR_CH0_DQ10_A	AC1	VSS_63	G6
DDR_CH0_DQ11_A	AC2	DDR_CH1_ZQ_C	G8
VSS_273	AC3	DDR_CH1_WCK0P_C	G9
VSS_274	AC4	VSS_64	G10
AVSS_21	AC5	DDR_CH1_LP4/4X_CS0_C	G11
HDMI/eDP_TX0_VDD_CMN_1V8	AC6	DDR_CH1_A0_C	G12
HDMI/eDP_TX0_VDD_IO_1V8	AC7	DDR_CH1_A2_D	G13
AVSS_22	AC8	DDR_CH1_A1_D	G14
HDMI/eDP_TX1_AVDD_0V75	AC9	VSS_65	G15
AVSS_23	AC10	DDR_CH1_DQS0N_D	G16
VSS_275	AC11	DDR_CH1_WCK1N_D	G18
VSS_276	AC12	VSS_66	G19
VDD_GPU_2	AC13	VCCIO1_1V8	G20
VDD_GPU_5	AC14	VSS_67	G21
VDD_GPU_9	AC15	VSS_68	G22
VSS_277	AC16	PCIE30_PORT0_AVDD1V8	G23
VDD_LOGIC_5	AC17	PCIE30_PORT0_AVDD0V75	G24
VDD_LOGIC_4	AC18	VSS_69	G25
VDD_LOGIC_3	AC19	PDM0_SDI0_M0/SPI1_CS1_M2/GPIO1_D5_d	G26
VSS_278	AC20	I2C3_SCL_M0/UART3_TX_M0/SPI4_MOSI_M0/GPIO1_C1_z	G27
VSS_279	AC21	I2C3_SDA_M0/UART3_RX_M0/SPI4_MISO_M0/GPIO1_C0_z	G29
VDD_NPU_4	AC22	PCIE20_2_REFCLKN	G30
VDD_NPU_1	AC23	PCIE20_2_REFCLKP	G31
VSS_280	AC24	VSS_70	G32
VCCIO6_1V8	AC25	PCIE30_PORT0_RX0P	G33
VCCIO6	AC26	PCIE30_PORT0_RX0N	G34
VSS_281	AC27	DDR_CH0_DQ0_B	H1
GMAC1_TXD0/I2S2_SDO_M1/UART2_RTSN/GPIO3_B3_u	AC28	DDR_CH0_DQ7_B	H2
GMAC1_TXD1/I2S2_MCLK_M1/UART2_CTSN/GPIO3_B4_u	AC29	VSS_71	H3
GMAC0_PPSCLK/TEST_CLKOUT_M1/HDMI_TX1_CEC_M0/UART9_RX_M0/SPI1_CS1_M0/GPIO2_C4_d	AC30	DDR_CH0_WCK1P_B	H4
GMAC0_RXD3/SDIO_D1_M0/FSPI_D1_M1/UART6_TX_M0/GPIO2_A7_u	AC31	DDR_CH0_WCK1N_B	H5
GMAC0_RXD2/SDIO_D0_M0/FSPI_D0_M1/UART6_RX_M0/GPIO2_A6_u	AC32	VSS_72	H6
GMAC0_TXD2/SDIO_D3_M0/FSPI_D3_M1/I2C8_SDA_M1/UART6_CTSN_M0/GPIO2_B1_u	AC33	DDR_CH0_ZQ_B	H7
GMAC0_TXD3/SDIO_CMD_M0/I2C3_SCL_M3/GPIO2_B2_u	AC34	DDR_CH1_WCK0N_C	H9
SDMMC_D1/PDM1_SDI2_M0/JTAG_TMS_M1/I2C3_SDA_M4/UART2_RX_M1/PWM9_M1/GPIO4_D1_u	AD1	VSS_73	H10
SDMMC_D0/PDM1_SDI3_M0/JTAG_TCK_M1/I2C3_SCL_M4/UART2_TX_M1/PWM8_M1/GPIO4_D0_u	AD2	DDR_CH1_LP4/4X_CS1_C	H11
OTP_VDDOTP_0V75	AD3	VSS_74	H12
NC	AD4	DDR_CH1_VDDQ_CKE	H13

Pin Name	Pin	Pin Name	Pin
AVSS_24	AD5	VSS_75	H14
HDMI/eDP_TX1_VDD_CMN_1V8	AD6	DDR_CH1_A0_D	H15
HDMI/eDP_TX1_VDD_IO_1V8	AD7	DDR_CH1_DQS0P_D	H16
AVSS_25	AD8	DDR_CH1_WCK1P_D	H18
HDMI/eDP_TX1_VDD_0V75	AD9	VSS_76	H19
AVSS_26	AD10	VCCIO4_1V8	H20
VSS_282	AD11	VCCIO4	H21
VSS_283	AD12	VSS_77	H22
VDD_GPU_3	AD13	PCIE30_PORT1_AVDD1V8	H23
VDD_GPU_4	AD14	PCIE30_PORT1_AVDD0V75	H24
VDD_GPU_8	AD15	VSS_78	H25
VSS_284	AD16	VSS_79	H26
VDD_LOGIC_0	AD17	AVSS_1	H28
VDD_LOGIC_1	AD18	PCIE20_2_TXN/SATA30_2_TXN/USB30_SSTXN	H29
VDD_LOGIC_2	AD19	PCIE20_2_TXP/SATA30_2_TXP/USB30_SSTXP	H30
VSS_285	AD20	AVSS_2	H31
VSS_286	AD21	PCIE20_1_REFCLKP	H32
VDD_NPU_3	AD22	PCIE20_1_REFCLKN	H33
VDD_NPU_0	AD23	DDR_CH0_DQ2_B	J1
VSS_287	AD24	DDR_CH0_DQ1_B	J2
VSS_288	AD25	VSS_80	J3
VSS_289	AD26	VSS_81	J4
GMAC1_RXD2/SDIO_D2_M1/I2S3_LRCK/AUDDSM_LP/FSPI_D2_M2/UART8_TX_M1/SPI4_CLK_M1/GPIO3_A2_u	AD27	VSS_82	J5
GMAC1_TXCLK/SDIO_CMD_M1/I2S3_SDI/AUDDSM_RP/UART8_RTSN_M1/SPI4_CS1_M1/GPIO3_A4_d	AD28	VSS_83	J6
GMAC1_TXEN/I2S2_SCLK_M1/UART3_TX_M1/PWM12_M0/GPI03_B5_u	AD29	DDR_CH0_DQS0N_B	J7
ETH0_REFCLK0_25M/I2S2_SDI_M0/I2C6_SCL_M2/SPI1_CS0_M0/GPIO2_C3_d	AD30	DDR_CH0_DQS0P_B	J8
GMAC0_RXD1/I2C6_SDA_M2/UART9_TX_M0/SPI1_MOSI_M0/GPIO2_C2_d	AD31	VSS_84	J10
GMAC0_RXD0/I2C2_SCL_M1/UART1_CTSN_M0/SPI1_MISO_M0/GPIO2_C1_d	AD32	VSS_85	J11
GMAC0_TXD0/I2S2_MCLK_M0/I2C5_SCL_M4/UART1_RX_M0/GPIO2_B6_d	AD33	VSS_86	J12
GMAC0_TXD1/I2S2_SCLK_M0/I2C5_SDA_M4/UART1_TX_M0/GPIO2_B7_d	AD34	VSS_87	J13
SDMMC_CLK/PDM1_CLK0_M0/TEST_CLKOUT_M0/MCU_JTAG_TMS_M0/UART5_TX_M0/GPIO4_D5_d	AE1	VSS_88	J14
SDMMC_CMD/PDM1_CLK1_M0/MCU_JTAG_TCK_M0/UART5_RX_M0/PWM7_IR_M1/GPIO4_D4_u	AE2	VSS_89	J15
VSS_290	AE3	VSS_90	J16
HDMI_RX_VPH3V3	AE4	VSS_91	J18
HDMI_RX_DVDD3V3	AE5	VSS_92	J19
AVSS_27	AE6	VSS_93	J20
AVSS_28	AE7	VSS_94	J21
HDMI_RX_AVDD0V75	AE8	VSS_95	J22
AVSS_29	AE9	VSS_96	J23
VSS_291	AE11	VSS_97	J24
VSS_292	AE12	VSS_98	J25
VSS_293	AE13	AVSS_3	J27
VSS_294	AE14	AVSS_4	J28
VSS_295	AE15	AVSS_5	J29
VSS_296	AE16	PCIE20_2_RXN/SATA30_2_RXN/USB30_SSRXN	J30
VSS_297	AE18	PCIE20_2_RXP/SATA30_2_RXP/USB30_SSRXP	J31
VSS_298	AE19	AVSS_6	J32
VSS_299	AE20	PCIE20_1_RXP/SATA30_1_RXP	J33
VSS_300	AE21	PCIE20_1_RXN/SATA30_1_RXN	J34
VDD_NPU_MEM_0	AE22	DDR_CH0_A4_B	K1
VDD_NPU_MEM_1	AE23	DDR_CH0_DQ3_B	K2
VSS_301	AE24	VSS_99	K3
VSS_302	AE26	DDR_CH0_WCK0N_B	K4
GMAC1_RXD3/SDIO_D3_M1/I2S3_SDO/AUDDSM_RN/FSPI_D3_M2/UART8_RX_M1/SPI4_CS0_M1/GPIO3_A3_u	AE27	DDR_CH0_WCK0P_B	K5
GMAC1_TXER/I2S2_SDI_M1/UART2_RX_M2/PWM3_IR_M1/GPI03_B2_d	AE28	VSS_100	K6
GMAC1_MCLKINOUT/I2S2_LRCK_M1/UART3_RX_M1/PWM13_M0/GPIO3_B6_d	AE29	DDR_CH0_RESET_B	K7
CLK32K_OUT1/GPIO2_C5_d	AE30	VSS_101	K8
GMAC0_RXDV_CRIS/UART7_RTSN_M0/PWM2_M2/SPI3_CS0_M0/GPIO4_C2_d	AE31	VSS_102	K9
GMAC0_RXCLK/SDIO_D2_M0/FSPI_D2_M1/I2C8_SCL_M1/UART6_RTSN_M0/GPIO2_B0_u	AE32	DDR_CH1_VDDQ_0	K11
GMAC0_TXCLK/SDIO_CLK_M0/FSPI_CLK_M1/I2C3_SDA_M3/GPIO2_B3_d	AE33	DDR_CH1_VDDQ_1	K12
GMAC0_TXEN/I2S2_LRCK_M0/I2C2_SDA_M1/UART1_RTSN_M0/SPI1_CLK_M0/GPIO2_C0_d	AE34	DDR_CH1_VDDQ_2	K13
SDMMC_D3/PDM1_SDI0_M0/JTAG_TMS_M0/I2C8_SDA_M0/UART5_RTSN_M0/PWM10_M1/GPIO4_D3_u	AF1	DDR_CH1_VDDQ_3	K14
SDMMC_D2/PDM1_SDI1_M0/JTAG_TCK_M0/I2C8_SCL_M0/UART5_CTSN_M0/GPIO4_D2_u	AF2	DDR_CH1_VDDQ_4	K15
HDMI_RX_REXT	AF3	DDR_CH1_PLL_AVDD1V8	K16
AVSS_30	AF4	VSS_103	K18
HDMI_RX_CLKN	AF5	VDD_LOGIC_8	K19
HDMI_RX_CLKP	AF6	VDD_LOGIC_9	K20
AVSS_31	AF7	VSS_104	K21
AVSS_32	AF8	VSS_105	K22

Pin Name	Pin	Pin Name	Pin
AVSS 33	AF11	VDD_CPU_BIG1_9	K23
AVSS 34	AF12	VDD_CPU_BIG1_0	K24
AVSS 35	AF13	AVSS 7	K26
AVSS 36	AF14	PCIE20_SATA30_USB30_2_AVDD_1V8	K27
AVSS 37	AF15	PCIE20_SATA30_USB30_2_AVDD_0V85	K28
AVSS 38	AF16	CLK32K_IN/CLK32K_OUT0/GPIO0_B2_u	K29
TSADC_TEST_OUT_TS	AF18	SPI2_CS0_M2/I2C1_SDA_M1/PWM5_M0/UART0_TX_M1/GPIO0_B1_z	K30
MIPI_D/C_PHY1_VREG	AF19	AVSS 8	K31
MIPI_D/C_PHY0_VREG	AF20	AVSS 9	K32
AVSS 39	AF21	PCIE20_1_TXP/SATA30_1_TXP	K33
VSS 303	AF22	PCIE20_1_TXN/SATA30_1_TXN	K34
VSS 304	AF24	VSS 106	L1
VSS 305	AF25	DDR_CH0_A5_B	L2
VSS 306	AF27	VSS 107	L3
VSS 307	AF28	DDR_CH0_LP4/4X_CKE1/LP5_CS1_B	L4
VSS 308	AF29	DDR_CH0_LP4/4X_CKE0/LP5_CS0_B	L5
VSS 309	AF30	VSS 108	L6
VSS 310	AF31	DDR_CH0_LP4/4X_CS0_B	L7
VSS 311	AF32	DDR_CH0_LP4/4X_CS1_B	L8
GMAC0_TXER/I2C0_SDA_M1/UART7_CTSN_M0/PWM7_IR_M3/SPI3_CLK_M0/GPIO4_C6_d	AF33	VSS_109	L9
GMAC0_MCLKINOUT/I2S2_SDO_M0/I2C7_SCL_M1/PWM4_M1/SPI3_CS1_M0/GPIO4_C3_d	AF34	DDR_CH0_VDDQ_CK	L10
HDMI_TX0_SBDN/eDP_TX0_AUXN	AG1	DDR_CH1_VDD_0	L11
HDMI_TX0_SBDP/eDP_TX0_AUXP	AG2	DDR_CH1_VDD_1	L12
AVSS 40	AG3	DDR_CH1_VDD_2	L13
HDMI_RX_D0N	AG4	DDR_CH1_VDD_3	L14
HDMI_RX_D0P	AG5	DDR_CH1_PLL_DVDD	L15
AVSS 41	AG6	DDR_CH1_PLL_AVSS	L16
AVSS 42	AG7	DDR_CH1_VDD_MIF_0	L17
USB20_HOST0_REXT	AG9	DDR_CH1_VDD_MIF_1	L18
AVSS 43	AG10	VSS 110	L19
USB20_AVDD_1V8	AG11	VSS 111	L20
AVSS 44	AG12	VSS 112	L21
TYPEC1_DP1_VDDH_1V8	AG13	VSS 113	L22
TYPEC0_DP0_VDDH_1V8	AG14	VDD_CPU_BIG1_8	L23
AVSS 45	AG15	VDD_CPU_BIG1_1	L24
TYPEC1_DP1_REXT	AG16	VSS 114	L25
AVSS 46	AG18	AVSS 10	L26
MIPI_D/C_PHY1_VDD	AG19	PCIE20_SATA30_1_AVDD_1V8	L27
MIPI_D/C_PHY0_VDD	AG20	PCIE20_SATA30_1_AVDD_0V85	L28
AVSS 47	AG21	SPI2_MISO_M2/I2C0_SCL_M0/GPIO0_B3_z	L29
AVSS 48	AG22	SPI2_CS1_M2/I2C1_SCL_M1/UART0_RX_M1/GPIO0_B0_z	L30
CIF_D13/PCIE20X1_2_PERSTN_M0/HDMI_RX_CEC_M1/UART4_TX_M1/PWM9_M2/SPI0_MISO_M3/GPIO3_D1_d	AG23	AVSS_11	L31
CIF_D15/PCIE30X2_WAKEN_M2/HDMI_RX_SDA_M1/I2C7_SDA_M2/UART9_CTSN_M2/PWM10_M2/SPI0_CLK_M3/GPIO3_D3_d	AG24	PCIE20_0_REFCLKP	L32
CIF_D14/PCIE30X2_CLKREQN_M2/HDMI_RX_SCL_M1/I2C7_SCL_M2/UART9_RTSN_M2/SPI0_MOSI_M3/GPIO3_D2_d	AG25	PCIE20_0_REFCLKN	L33
CIF_D10/PCIE30X4_PERSTN_M2/HDMI_TX1_SCL_M1/SPI3_MISO_M3/GPIO3_C6_u	AG26	DDR_CH0_CKB_B	M1
GMAC1_RXD1/MIPI_CAMERA3_CLK_M1/PWM9_M0/GPIO3_B0_u	AG28	DDR_CH0_CK_B	M2
GMAC1_RXD0/MIPI_CAMERA2_CLK_M1/PWM8_M0/GPIO3_A7_u	AG29	VSS_115	M3
VSS 312	AG30	DDR_CH0_A1_B	M5
MIPI_CS11_D0P	AG31	VSS 116	M6
MIPI_CS11_D0N	AG32	DDR_CH0_A6_B	M7
MIPI_CS10_D0P	AG33	DDR_CH0_A0_B	M8
MIPI_CS10_D0N	AG34	VSS 117	M9
HDMI_TX0_D3N/eDP_TX0_D3N	AH2	DDR_CH0_VDDQ_0	M10
HDMI_TX0_D3P/eDP_TX0_D3P	AH3	DDR_CH0_PLL_AVSS	M11
AVSS 49	AH4	DDR_CH0_PLL_AVDD1V8	M12
HDMI_RX_D1N	AH5	DDR_CH1_VDDQ_CK	M13
HDMI_RX_D1P	AH6	VSS 118	M14
AVSS 50	AH8	VSS 119	M15
USB20_HOST1_REXT	AH9	VDD_CPU_BIG0_0	M16
USB20_DVDD_0V75	AH10	VDD_CPU_BIG0_9	M17
AVSS 51	AH11	VSS 120	M18
AVSS 52	AH12	VDD_CPU_BIG0_MEM_0	M19
TYPEC1_DP1_VDD_0V85	AH13	VSS 121	M20
TYPEC0_DP0_VDDA_0V85	AH14	VDD_CPU_BIG1_MEM_0	M21
AVSS 53	AH15	VSS 122	M22
TYPEC0_DP0_REXT	AH16	VDD_CPU_BIG1_7	M23
SARADC_AVDD_1V8	AH18	VDD_CPU_BIG1_2	M24
MIPI_D/C_PHY1_VDD_1V2	AH19	VSS 123	M25
MIPI_D/C_PHY0_VDD_1V2	AH20	AVSS 12	M26
AVSS 54	AH21	PCIE20_SATA30_0_AVDD_1V8	M27
AVSS 55	AH22	PCIE20_SATA30_0_AVDD_0V85	M28
AVSS 56	AH23	TVSS	M29
CIF_D12/PCIE20X1_2_WAKEN_M0/HDMI_TX0_SDA_M2/I2C5_SDA_M0/UART4_RX_M1/PWM8_M2/SPI3_CLK_M3/GPIO3_D0_u	AH24	PMIC_INT_L/GPIO0_A7_u	M30
CIF_D9/FSPI_CS1N_M2/PCIE30X4_WAKEN_M2/HDMI_TX1_SDA_M1/UART5_RX_M1/SPI3_CS1_M3/GPIO3_C5_u	AH25	NPOR_u	M31

Pin Name	Pin	Pin Name	Pin
CIF_D8/FSPI_CS0N_M2/PCIE30X4_CLKREQN_M2/HDMI_TX1_CEC_M2/UART5_TX_M1/SPI3_CS0_M3/GPIO3_C4_u	AH26	AVSS_13	M32
ETH1_REFCLK0_25M/MIPI_CAMERA1_CLK_M1/I2C4_SCL_M0/GPIO3_A6_d	AH27	PCIE20_0_TXN/SATA30_0_TXN	M33
GMAC1_RXDV_CRCS/MIPI_CAMERA4_CLK_M1/UART2_TX_M2/PWM2_M1/GPIO3_B1_d	AH29	PCIE20_0_TXP/SATA30_0_TXP	M34
GMAC1_RXCLK/SDIO_CLK_M1/MIPI_CAMERA0_CLK_M1/FSPI_CLK_M2/I2C4_SDA_M0/UART8_CTSN_M1/GPIO3_A5_d	AH30	DDR_CH0_CKB_A	N1
MIPI_CSI1_D1P	AH31	DDR_CH0_CK_A	N2
MIPI_CSI1_D1N	AH32	VSS_124	N3
MIPI_CSI0_D1P	AH33	DDR_CH0_A3_B	N4
MIPI_CSI0_D1N	AH34	DDR_CH0_A2_B	N5
HDMI_TX0_D0N/eDP_TX0_D0N	AJ1	VSS_125	N6
HDMI_TX0_D0P/eDP_TX0_D0P	AJ2	DDR_CH0_LP4/4X_CKE1/LP5_CS1_A	N7
AVSS_57	AJ3	DDR_CH0_VDDQ_CKE	N8
HDMI_RX_D2N	AJ4	VSS_126	N9
HDMI_RX_D2P	AJ5	DDR_CH0_VDDQ_1	N10
AVSS_58	AJ7	VSS_127	N11
AVSS_59	AJ8	DDR_CH0_PLL_DVDD	N12
AVSS_60	AJ9	DDR_CH0_VDD_MIF_0	N13
USB20_AVDD_3V3	AJ10	VSS_128	N14
AVSS_61	AJ11	VSS_129	N15
AVSS_62	AJ12	VDD_CPU_BIG0_1	N16
TYPEC1_DP1_VDDA_0V85	AJ13	VDD_CPU_BIG0_8	N17
TYPEC0_DP0_VDD_0V85	AJ14	VSS_130	N18
AVSS_63	AJ15	VDD_CPU_BIG0_MEM_1	N19
AVSS_64	AJ16	VSS_131	N20
AVSS_65	AJ18	VDD_CPU_BIG1_MEM_1	N21
MIPI_D/C_PHY1_VDD_1V8	AJ19	VSS_132	N22
MIPI_D/C_PHY0_VDD_1V8	AJ20	VDD_CPU_BIG1_6	N23
AVSS_66	AJ21	VDD_CPU_BIG1_3	N24
AVSS_67	AJ22	VSS_133	N25
AVSS_68	AJ23	VSS_134	N26
CIF_D11/PCIE20X1_2_CLKREQN_M0/HDMI_TX0_SCL_M2/I2C5_SCL_M0/SPI3_MOSI_M3/GPIO3_C7_u	AJ24	OSC_1V8	N27
BT1120_D14/PCIE20X1_2_WAKEN_M1/HDMI_TX0_SDA_M0/I2C8_SCL_M3/SPI3_CS0_M1/GPIO4_C0_u	AJ25	PMUIO1_1V8	N28
BT1120_D11/PCIE30X4_WAKEN_M1/HDMI_RX_CEC_M0/SATA1_ACT_LED_M0/UART9_RX_M1/PWM12_M1/SPI3_MISO_M1/GPIO4_B5_d	AJ26	VSS_135	N29
BT1120_D12/PCIE30X4_PERSTN_M1/HDMI_RX_HPDIN_M0/SATA0_ACT_LED_M0/I2C5_SCL_M1/PWM13_M1/SPI3_MOSI_M1/GPIO4_B6_d	AJ27	SPI2_MOSI_M2/I2C0_SDA_M0/GPIO0_A6_z	N30
BT1120_D13/PCIE20X1_2_CLKREQN_M1/HDMI_TX0_SCL_M0/I2C5_SDA_M1/SPI3_CLK_M1/GPIO4_B7_u	AJ28	SPI2_CLK_M2/SDMMC_PWREN/PMU_DEBUG/GPIO0_A5_d	N31
VSS_313	AJ30	AVSS_14	N32
MIPI_CSI1_CLK0P	AJ31	PCIE20_0_RXP/SATA30_0_RXP	N33
MIPI_CSI1_CLK0N	AJ32	PCIE20_0_RXN/SATA30_0_RXN	N34
MIPI_CSI0_CLK0P	AJ33	VSS_136	P1
MIPI_CSI0_CLK0N	AJ34	DDR_CH0_A5_A	P2
HDMI_TX0_D1N/eDP_TX0_D1N	AK2	VSS_137	P3
HDMI_TX0_D1P/eDP_TX0_D1P	AK3	DDR_CH0_A2_A	P4
AVSS_69	AK4	DDR_CH0_A3_A	P5
AVSS_70	AK5	VSS_138	P6
USB20_HOST0_DP	AK6	DDR_CH0_LP4/4X_CKE0/LP5_CS0_A	P7
AVSS_71	AK7	VSS_139	P8
TYPEC1_USB20_OTG_ID	AK8	VSS_140	P9
TYPEC1_USB20_OTG_DP	AK9	DDR_CH0_VDDQ_2	P10
AVSS_72	AK10	VSS_141	P11
AVSS_73	AK11	DDR_CH0_VDD_3	P12
AVSS_74	AK12	DDR_CH0_VDD_MIF_1	P13
AVSS_75	AK13	VSS_142	P14
AVSS_76	AK14	VSS_143	P15
SARADC_IN5	AK15	VDD_CPU_BIG0_2	P16
SARADC_IN2	AK16	VDD_CPU_BIG0_7	P17
SARADC_IN7	AK17	VSS_144	P18
MIPI_DPHY1_RX_D0P/MIPI_CPHY1_RX_TRIO0_B	AK18	VSS_145	P19
MIPI_DPHY1_RX_D1P/MIPI_CPHY1_RX_TRIO1_A	AK19	VSS_146	P20
MIPI_DPHY1_RX_CLKP/MIPI_CPHY1_RX_TRIO1_C	AK20	VSS_147	P21
MIPI_DPHY1_RX_D2P/MIPI_CPHY1_RX_TRIO2_B	AK21	VSS_148	P22
MIPI_DPHY1_RX_D3P/NO_USE	AK22	VDD_CPU_BIG1_5	P23
AVSS_77	AK23	VDD_CPU_BIG1_4	P24
BT1120_D15/SPDIF1_TX_M2/PCIE20X1_2_PERSTN_M1/HDMI_TX0_CEC_M0/I2C8_SDA_M3/PWM6_M1/SPI3_CS1_M1/GPIO4_C1_d	AK24	VSS_149	P25
CIF_HREF/BT1120_D8/I2S1_SDO1_M0/PCIE30X1_1_BUTTON_RSTN/I2C7_SCL_M3/UART8_RTSN_M0/PWM14_M1/SPI0_CS0_M1/GPIO4_B2_u	AK25	VSS_150	P26
CIF_CLKIN/BT1120_CLKOUT/I2S1_SDI3_M0/PCIE30X2_PERSTN_M1/I2C6_SDA_M3/UART8_TX_M0/SPI2_CS1_M1/GPIO4_B0_d	AK26	PMU_0V75	P27
CIF_D5/BT1120_D5/I2S1_SDI0_M0/PCIE30X1_0_PERSTN_M1/I2C3_SDA_M2/UART3_TX_M2/SPI2_MOSI_M1/GPIO4_A5_d	AK27	PMUIO2	P28
VSS_314	AK28	I2S1_MCLK_M1/JTAG_TCK_M2/I2C1_SCL_M0/UART2_TX_M0/PCIE30X1_1_CLKREQN_M0/GPIO0_B5_d	P29
VSS_315	AK29	I2S1_SDIO_M1/GPU_AVS/UART0_TX_M0/I2C4_SCL_M2/DP1_HPDIN_M1/PWM4_M0/PCIE30X1_0_PERSTN_M0/GPIO0_C5_u	P30
CIF_D0/BT1120_D0/I2S1_MCLK_M0/PCIE30X1_1_CLKREQN_M	AK30	SDMMC_DET/GPIO0_A4_u	P31

Pin Name	Pin	Pin Name	Pin
1/UART9_RTSN_M1/SPI0_MISO_M1/GPIO4_A0_d			
MIPI_CSI1_D2P	AK31	TSADC_SHUT_ORG/TSADC_SHUT/GPIO0_A1_z	P32
MIPI_CSI1_D2N	AK32	REFCLK_OUT/GPIO0_A0_d	P33
MIPI_CSI0_D2P	AK33	VSS_151	P34
MIPI_CSI0_D2N	AK34	DDR_CH0_A4_A	R1
HDMI_TX0_D2N/eDP_TX0_D2N	AL1	DDR_CH0_DQ3_A	R2
HDMI_TX0_D2P/eDP_TX0_D2P	AL2	VSS_152	R3
AVSS_78	AL3	VSS_153	R5
AVSS_79	AL4	DDR_CH0_LP4/4X_CS0_A	R6
AVSS_80	AL5	DDR_CH0_LP4/4X_CS1_A	R7
USB20_HOST0_DM	AL6	VSS_154	R8
USB20_HOST1_DP	AL7	VSS_155	R9
TYPEC1_USB20_VBUSDET	AL8	DDR_CH0_VDDQ_3	R10
TYPEC1_USB20_OTG_DM	AL9	VSS_156	R11
TYPEC1_SBU1/DP1_AUXP	AL10	DDR_CH0_VDD_2	R12
AVSS_81	AL11	VSS_157	R13
TYPEC0_USB20_OTG_DP	AL12	VDD_VDENC_0	R14
AVSS_82	AL13	VSS_158	R15
TYPEC0_USB20_OTG_ID	AL14	VDD_CPU_BIG0_3	R16
TYPEC0_SBU1/DP0_AUXP	AL15	VDD_CPU_BIG0_6	R17
SARADC_IN1	AL16	VSS_159	R18
SARADC_IN6	AL17	VSS_160	R19
MIPI_DPHY1_RX_D0N/MIPI_CPHY1_RX_TRIO0_A	AL18	VSS_161	R20
MIPI_DPHY1_RX_D1N/MIPI_CPHY1_RX_TRIO0_C	AL19	VSS_162	R21
MIPI_DPHY1_RX_CLKN/MIPI_CPHY1_RX_TRIO1_B	AL20	VSS_163	R22
MIPI_DPHY1_RX_D2N/MIPI_CPHY1_RX_TRIO2_A	AL21	VSS_164	R23
MIPI_DPHY1_RX_D3N/MIPI_CPHY1_RX_TRIO2_C	AL22	VSS_165	R24
AVSS_83	AL23	VSS_166	R25
MIPI_CAMERA0_CLK_M0/SPDIF1_TX_M1/I2S1_SDO0_M0/PCIE30X1_0_BUTTON_RSTN/SATA2_ACT_LED_M0/I2C6_SCL_M3/UART8_RX_M0/SPI0_CS1_M1/GPIO4_B1_u	AL24	VSS_167	R26
VSS_316	AL25	PMUIO2_1V8	R27
CIF_CLKOUT/BT1120_D10/I2S1_SDO3_M0/PCIE30X4_CLKREQ_N_M1/DP0_HPDIN_M0/SPDIF0_TX_M1/UART9_TX_M1/PWM11_IR_M1/GPIO4_B4_u	AL26	VSS_168	R28
CIF_D6/BT1120_D6/I2S1_SDI1_M0/PCIE30X2_CLKREQN_M1/I2C5_SCL_M2/UART3_RX_M2/SPI2_CLK_M1/GPIO4_A6_d	AL27	I2S1_SCLK_M1/JTAG_TMS_M2/I2C1_SDA_M0/UART2_RX_M0/PCIE30X1_1_WAKEN_M0/GPIO0_B6_d	R29
CIF_D4/BT1120_D4/PCIE30X1_0_WAKEN_M1/I2C3_SCL_M2/UART0_RX_M2/SPI2_MISO_M1/GPIO4_A4_d	AL28	PDM0_CLK1_M1/PWM2_M0/UART0_RX_M0/I2C4_SDA_M2/DP0_HPDIN_M1/PCIE30X1_0_WAKEN_M0/GPIO0_C4_d	R30
CIF_D3/BT1120_D3/PCIE30X1_0_CLKREQN_M1/UART0_TX_M2/GPIO4_A3_d	AL29	PMIC_SLEEP2/GPIO0_A3_d	R31
CIF_D1/BT1120_D1/I2S1_SCLK_M0/PCIE30X1_1_WAKEN_M1/UART9_CTSN_M1/SPI0_MOSI_M1/GPIO4_A1_d	AL30	PMIC_SLEEP1/GPIO0_A2_d	R32
MIPI_CSI1_D3P	AL31	VSS_169	R33
MIPI_CSI1_D3N	AL32	XIN_24M	R34
MIPI_CSI0_D3P	AL33	DDR_CH0_DQ2_A	T1
MIPI_CSI0_D3N	AL34	DDR_CH0_DQ1_A	T2
HDMI/eDP_TX0_REXT	AM2	VSS_170	T3
HDMI_TX1_D3P/eDP_TX1_D3P	AM3	DDR_CH0_RESET_A	T4
AVSS_84	AM4	DDR_CH0_A6_A	T5
HDMI_TX1_D1P/eDP_TX1_D1P	AM5	VSS_171	T6
USB20_HOST1_DM	AM7	DDR_CH0_A0_A	T7
AVSS_85	AM8	DDR_CH0_A1_A	T8
AVSS_86	AM9	VSS_172	T9
TYPEC1_SBU2/DP1_AUXN	AM10	DDR_CH0_VDDQ_4	T10
TYPEC0_USB20_OTG_DM	AM12	VSS_173	T11
TYPEC0_USB20_VBUSDET	AM14	DDR_CH0_VDD_1	T12
TYPEC0_SBU2/DP0_AUXN	AM15	VSS_174	T13
SARADC_IN0_BOOT	AM16	VDD_VDENC_1	T14
SARADC_IN4	AM17	VSS_175	T15
AVSS_87	AM18	VDD_CPU_BIG0_4	T16
AVSS_88	AM20	VDD_CPU_BIG0_5	T17
AVSS_89	AM22	VSS_176	T18
AVSS_90	AM23	VSS_177	T19
AVSS_91	AM24	VSS_178	T20
CIF_VSYNC/BT1120_D9/I2S1_SDO2_M0/PCIE20X1_2_BUTTON_RSTN/I2C7_SDA_M3/UART8_CTSN_M0/PWM15_IR_M1/GPIO4_B3_u	AM25	VDD_CPU_LIT_MEM_1	T21
AVSS_92	AM26	VDD_CPU_LIT_MEM_0	T22
CIF_D7/BT1120_D7/I2S1_SDI2_M0/PCIE30X2_WAKEN_M1/I2C5_SDA_M2/SPI2_CS0_M1/GPIO4_A7_d	AM27	VSS_179	T23
AVSS_93	AM28	VSS_180	T24
CIF_D2/BT1120_D2/I2S1_LRCK_M0/PCIE30X1_1_PERSTN_M1/SPI0_CLK_M1/GPIO4_A2_d	AM29	VSS_181	T25
VSS_317	AM30	VSS_182	T26
MIPI_CSI1_CLK1P	AM31	VSS_183	T27
MIPI_CSI1_CLK1N	AM32	I2S1_LRCK_M1/PWM0_M0/I2C2_SCL_M0/SPI0_CS1_M0/PCIE30X1_1_PERSTN_M0/GPIO0_B7_d	T28
MIPI_CSI0_CLK1P	AM33	I2S1_SDI1_M1/NPU_AV5/UART0_RTSN/PWM5_M1/SPI0_CLK_M0/PCIE30X4_CLKREQN_M0/SATA_CP_POD/GPIO0_C6_u	T29
MIPI_CSI0_CLK1N	AM34	PMIC_SLEEP5/GPIO0_C3_d	T30
HDMI/eDP_TX1_REXT	AN1	PDM0_CLK0_M1/PWM1_M0/I2C2_SDA_M0/SPI0_MOSI_M0/PCIE30X1_0_CLKREQN_M0/GPIO0_C0_d	T31
HDMI_TX1_SBDP/eDP_TX1_AUXP	AN2	PMIC_SLEEP4/GPIO0_C2_d	T32
HDMI_TX1_D0P/eDP_TX1_D0P	AN4	VSS_184	T33
HDMI_TX1_D1N/eDP_TX1_D1N	AN5	XOUT_24M	T34

Pin Name	Pin	Pin Name	Pin
HDMI TX1_D2P/eDP_TX1_D2P	AN6	DDR_CH0_DQ0_A	U1
AVSS_94	AN7	DDR_CH0_DQ7_A	U2
TYPEC1_SSRX1P/DP1_TX0P	AN8	VSS_185	U3
TYPEC1_SSTX1N/DP1_TX1N	AN9	DDR_CH0_DQ50N_A	U4
TYPEC1_SSRX2P/DP1_TX2P	AN10	DDR_CH0_DQ50P_A	U5
TYPEC1_SSTX2N/DP1_TX3N	AN11	DDR_CH0_VDD_0	U11
AVSS_95	AN12	VSS_186	U12
TYPEC0_SSRX1P/DP0_TX0P	AN13	VSS_187	U13
TYPEC0_SSTX1N/DP0_TX1N	AN14	VDD_VDENC_2	U14
TYPEC0_SSRX2P/DP0_TX2P	AN15	VSS_188	U15
TYPEC0_SSTX2N/DP0_TX3N	AN16	VSS_189	U16
SARADC_IN3	AN17	VSS_190	U17
MIPI_DPHY1_TX_D0P/MIPI_CPHY1_TX_TRIO0_B	AN18	PLL_AVDD1V8	U18
MIPI_DPHY1_TX_D1P/MIPI_CPHY1_TX_TRIO1_A	AN19	PLL_AVSS	U19
MIPI_DPHY1_TX_CLKP/MIPI_CPHY1_TX_TRIO1_C	AN20	VSS_191	U20
MIPI_DPHY1_TX_D2P/MIPI_CPHY1_TX_TRIO2_B	AN21	VDD_CPU_LIT_7	U21
MIPI_DPHY1_TX_D3P/NO_USE	AN22	VDD_CPU_LIT_0	U22
AVSS_96	AN23	VSS_192	U23
MIPI_DPHY0_TX_D0P/MIPI_CPHY0_TX_TRIO0_B	AN24	VSS_193	U24
MIPI_DPHY0_TX_D1P/MIPI_CPHY0_TX_TRIO1_A	AN25	VSS_194	U30
MIPI_DPHY0_TX_CLKP/MIPI_CPHY0_TX_TRIO1_C	AN26	VSS_195	U31
MIPI_DPHY0_TX_D2P/MIPI_CPHY0_TX_TRIO2_B	AN27	PMIC_SLEEP3/GPIO0_C1_d	U32
MIPI_DPHY0_TX_D3P/NO_USE	AN28	LITCPU_AV5/SPI3_CLK_M2/GPIO0_D3_u	U33
MIPI_DPHY0_RX_D0P/MIPI_CPHY0_RX_TRIO0_B	AN29	VSS_196	U34
HDMI_TX1_D3N/eDP_TX1_D3N	AN3	DDR_CH0_DQ6_A	V1
MIPI_DPHY0_RX_D1P/MIPI_CPHY0_RX_TRIO1_A	AN30	DDR_CH0_DQ5_A	V2
AVSS_97	AN31	VSS_197	V3
MIPI_DPHY0_RX_CLKP/MIPI_CPHY0_RX_TRIO1_C	AN32	VSS_198	V4
MIPI_DPHY0_RX_D2P/MIPI_CPHY0_RX_TRIO2_B	AN33	VSS_199	V5
MIPI_DPHY0_RX_D3P/NO_USE	AN34	DDR_CH0_WCK0N_A	V6
AVSS_98	AP1	DDR_CH0_WCK0P_A	V7
HDMI_TX1_D0N/eDP_TX1_D0N	AP4	VSS_200	V8
HDMI_TX1_D2N/eDP_TX1_D2N	AP6	VSS_201	V9
TYPEC1_USB20_OTG1_REXT	AP7	VSS_202	V10
TYPEC1_SSRX1N/DP1_TX0N	AP8	VSS_203	V11
TYPEC1_SSTX1P/DP1_TX1P	AP9	VDD_VDENC_MEM_0	V12
TYPEC1_SSRX2N/DP1_TX2N	AP10	VDD_VDENC_MEM_1	V13
TYPEC1_SSTX2P/DP1_TX3P	AP11	VDD_VDENC_3	V14
TYPEC0_USB20_OTG0_REXT	AP12	VSS_204	V15
TYPEC0_SSRX1N/DP0_TX0N	AP13	VDD_LOGIC_6	V16
TYPEC0_SSTX1P/DP0_TX1P	AP14	VDD_LOGIC_7	V17
TYPEC0_SSRX2N/DP0_TX2N	AP15	VSS_205	V18
TYPEC0_SSTX2P/DP0_TX3P	AP16	VSS_206	V19
AVSS_99	AP17	PLL_DVDD0V75	V20
MIPI_DPHY1_TX_D0N/MIPI_CPHY1_TX_TRIO0_A	AP18	VDD_CPU_LIT_6	V21
MIPI_DPHY1_TX_D1N/MIPI_CPHY1_TX_TRIO0_C	AP19	VDD_CPU_LIT_1	V22
HDMI_TX1_SBDN/eDP_TX1_AUXN	AP2	VSS_207	V23
MIPI_DPHY1_TX_CLKN/MIPI_CPHY1_TX_TRIO1_B	AP20	VSS_208	V24
MIPI_DPHY1_TX_D2N/MIPI_CPHY1_TX_TRIO2_A	AP21	VSS_209	V25
MIPI_DPHY1_TX_D3N/MIPI_CPHY1_TX_TRIO2_C	AP22	EMMCIO_1V8	V26
AVSS_100	AP23	VSS_210	V27
MIPI_DPHY0_TX_D0N/MIPI_CPHY0_TX_TRIO0_A	AP24	I2S1_SDO3_M1/CPU_BIG1_AV5/I2C1_SDA_M2/HDMI_TX0_SCL_M1/SPI3_CS1_M2/SATA_MP_SWITCH/GPIO0_D5_u	V28
MIPI_DPHY0_TX_D1N/MIPI_CPHY0_TX_TRIO0_C	AP25	I2S1_SDO2_M1/PDM0_SDI2_M1/PWM3_IR_M0/I2C1_SCL_M2/HDMI_TX0_SDA_M1/SPI3_CS0_M2/PCIE30X2_PERRSTN_M0/SATA_CPDET/GPIO0_D4_u	V29
MIPI_DPHY0_TX_CLKN/MIPI_CPHY0_TX_TRIO1_B	AP26	VSS_211	V30
MIPI_DPHY0_TX_D2N/MIPI_CPHY0_TX_TRIO2_A	AP27	I2S1_SDI2_M1/PDM0_SDI0_M1/I2C6_SDA_M0/UART1_RTSN_M2/PWM6_M0/SPI0_MISO_M0/PCIE30X4_WAKEN_M0/GPIO0_C7_d	V31
MIPI_DPHY0_TX_D3N/MIPI_CPHY0_TX_TRIO2_C	AP28	EMMC_D2/FSPI_D2_M0/GPIO2_D2_u	V32
MIPI_DPHY0_RX_D0N/MIPI_CPHY0_RX_TRIO0_A	AP29	EMMC_D7/FSPI_CS1N_M0/GPIO2_D7_u	V33
MIPI_DPHY0_RX_D1N/MIPI_CPHY0_RX_TRIO0_C	AP30	EMMC_CLKOUT/GPIO2_A1_d	V34
MIPI_DPHY0_RX_CLKN/MIPI_CPHY0_RX_TRIO1_B	AP31	DDR_CH0_DQ4_A	W1
MIPI_DPHY0_RX_D2N/MIPI_CPHY0_RX_TRIO2_A	AP32	VSS_212	W2
MIPI_DPHY0_RX_D3N/MIPI_CPHY0_RX_TRIO2_C	AP33	VSS_213	W3
AVSS_101	AP34	DDR_CH0_WCK1P_A	W4
DDR_CH0_DQ11_B	B1	DDR_CH0_WCK1N_A	W5
DDR_CH1_DQ11_C	B2	VSS_214	W6
DDR_CH1_DQ9_C	B3	VSS_215	W7
DDR_CH1_DQ15_C	B4	DDR_CH0_ZQ_A	W8
DDR_CH1_DQ13_C	B5	VSS_216	W9
VSS_5	B6	VSS_217	W10
DDR_CH1_DQ5_C	B7	VSS_218	W11
DDR_CH1_DQ7_C	B8	VSS_219	W12
DDR_CH1_DQ1_C	B9	VDD_VDENC_5	W13
DDR_CH1_DQ3_C	B10	VDD_VDENC_4	W14
DDR_CH1_A5_C	B11	VSS_220	W15
DDR_CH1_CK_C	B12	VSS_221	W16
DDR_CH1_CK_D	B13	VSS_222	W17
DDR_CH1_A5_D	B14	VSS_223	W18
DDR_CH1_DQ3_D	B15	VSS_224	W19
DDR_CH1_DQ1_D	B16	VSS_225	W20
DDR_CH1_DQ7_D	B17	VDD_CPU_LIT_5	W21
DDR_CH1_DQ5_D	B18	VDD_CPU_LIT_2	W22
VSS_6	B19	VSS_226	W23
DDR_CH1_DQ13_D	B20	VSS_227	W24

Pin Name	Pin	Pin Name	Pin
DDR_CH1_DQ15_D	B21	VCCIO5_1V8	W25
DDR_CH1_DQ9_D	B22	VCCIO5	W26
DDR_CH1_DQ11_D	B23	VSS_228	W27
VSS_7	B24	PMIC_SLEEP6/PDM0_SDI3_M1/GPIO0_D6_d	W28
HDMI_TX1_SCL_M2/SPI2_MISO_M0/GPIO1_A4_d	B25	I2S1_SDO1_M1/I2C0_SDA_M2/UART1_RX_M2/HDMI_RX_SCL_M0/SPI3_MOSI_M2/PCIE30X2_WAKEN_M0/HDMI_TX1_CEC_M1/GPIO0_D2_u	W29
HDMI_TX0_HPD_M0/SPI2_MOSI_M0/GPIO1_A5_d	B26	I2S1_SDO0_M1/CPU_BIG0_AVS/I2C0_SCL_M2/UART0_CTSN/UART1_TX_M2/HDMI_RX_SDA_M0/SPI0_CS0_M0/PCIE30X2_CLKREQN_M0/HDMI_TX0_CEC_M1/GPIO0_D1_u	W30
VSS_8	B27	I2S1_SDI3_M1/PDM0_SDI1_M1/I2C6_SCL_M0/UART1_CTSN_M2/PWM7_IR_M0/SPI3_MISO_M2/PCIE30X4_PERS_TN_M0/GPIO0_D0_d	W31
PCIE30_PORT1_REF_CLKN	B28	EMMC_D6/FSPI_CS0N_M0/GPIO2_D6_u	W32
PCIE30_PORT1_TX1N	B29	EMMC_D1/FSPI_D1_M0/GPIO2_D1_u	W33
PCIE30_PORT1_TX0P	B30	EMMC_CMD/FSPI_CLK_M0/GPIO2_A0_u	W34
PCIE30_PORT1_RX1N	B31	DDR_CH0_DQ12_A	Y1
PCIE30_PORT1_RX0P	B32	DDR_CH0_DQ13_A	Y2
VSS_9	B33	VSS_229	Y3
PCIE30_PORT0_RESREF	B34	DDR_CH0_DM0_A	Y4
DDR_CH0_DQ9_B	C1	VSS_230	Y5
DDR_CH0_DQ10_B	C2	VSS_231	Y6
VSS_10	C3	VCCIO2	Y7
VSS_11	C4	VSS_232	Y8
VSS_17	C10	VSS_233	Y9
VSS_18	C11	VSS_234	Y10
VSS_19	C12	VSS_235	Y11
VSS_20	C13	VSS_236	Y12
VSS_21	C14	VSS_237	Y13
VSS_22	C15	VSS_238	Y14
VSS_23	C16	VSS_239	Y15
VSS_24	C17	VSS_240	Y16
VSS_25	C18	VSS_241	Y17
DDR_CH1_RESET_D	C19	VSS_242	Y18
VSS_26	C20	VSS_243	Y19
VSS_27	C21	VSS_244	Y20
VSS_28	C22	VDD_CPU_LIT_4	Y21
VSS_29	C23	VDD_CPU_LIT_3	Y22
HDMI_TX1_HPD_M0/SPI2_CLK_M0/GPIO1_A6_d	C24	VSS_245	Y23
PDM1_SDI0_M1/PCIE30X1_1_PERSTN_M2/PWM3_IR_M3/SPI2_CS0_M0/GPIO1_A7_u	C25	VSS_246	Y24
VSS_30	C26	VCCIO3_1V8	Y26
PDM1_SDI1_M1/PCIE30X4_CLKREQN_M3/SPI2_CS1_M0/GPIO1_B0_u	C27	GMAC1_PPCLK/PCIE30X2_BUTTON_RSTN/UART7_RX_M1/SPI1_CLK_M1/GPIO3_C1_d	Y27
VSS_31	C28	VSS_247	Y28
PCIE30_PORT1_TX1P	C29	GMAC1_PPSTRIG/I2C3_SDA_M1/UART7_TX_M1/SPI1_MISO_M1/GPIO3_C0_d	Y29
VSS_32	C30	GMAC1_MDIO/MIPI_TE1/I2C8_SDA_M4/UART7_CTSN_M1/PWM15_IR_M0/SPI1_CS1_M1/GPIO3_C3_d	Y30
PCIE30_PORT1_RX1P	C31	GMAC1_MDC/MIPI_TE0/I2C8_SCL_M4/UART7_RTSN_M1/PWM14_M0/SPI1_CS0_M1/GPIO3_C2_d	Y31
VSS_33	C32	EMMC_D4/I2C1_SCL_M3/UART5_RX_M2/GPIO2_D4_u	Y32
PCIE30_PORT0_TX1P	C33	EMMC_D0/FSPI_D0_M0/GPIO2_D0_u	Y33
PCIE30_PORT0_TX1N	C34	EMMC_DATA_STROBE/I2C2_SDA_M2/UART5_CTSN_M1/GPIO2_A2_d	Y34

Chapter 3 Electrical Specification

3.1 Absolute Ratings

The below table provides the absolute ratings.

Absolute maximum or minimum ratings specify the values beyond which the device may be damaged permanently. Long-term exposure to absolute maximum ratings conditions may affect device reliability.

Table 3-1 Absolute ratings

Parameters	Related Power Group	Min	Max	Unit
Supply voltage for CPU	VDD_CPU_BIG0 VDD_CPU_BIG1 VDD_CPU_LIT	-0.3	1.1	V
Supply voltage for CPU memory	VDD_CPU_BIG0_MEM VDD_CPU_BIG1_MEM VDD_CPU_LIT_MEM	-0.3	1.1	V
Supply voltage for GPU	VDD_GPU	-0.3	1.1	V
Supply voltage for GPU memory	VDD_GPU_MEM	-0.3	1.1	V
Supply voltage for NPU	VDD_NPU	-0.3	1.1	V
Supply voltage for NPU memory	VDD_NPU_MEM	-0.3	1.1	V
Supply voltage for VCODEC	VDD_VDENC	-0.3	0.95	V
Supply voltage for VCODEC memory	VDD_VDENC_MEM	-0.3	0.95	V
Supply voltage for core logic	VDD_LOGIC	-0.3	0.95	V
0.75V supply voltage	PMU_0V75 PLL_DVDD0V75 USB20_DVDD_0V75 HDMI/eDP_TX0_VDD_0V75 HDMI/eDP_TX0_AVDD_0V75 HDMI/eDP_TX1_VDD_0V75 HDMI/eDP_TX1_AVDD_0V75 HDMI_RX_AVDD0V75 MIPI_CSI0_AVCC0V75 MIPI_CSI1_AVCC0V75 PCIE30_PORT0_AVDD0V75 PCIE30_PORT1_AVDD0V75 OTP_VDDOTP_0V75	-0.3	0.95	V
0.85V supply voltage	DDR_CH0_VDD DDR_CH0_VDD_MIF DDR_CH0_PLL_DVDD DDR_CH1_VDD DDR_CH1_VDD_MIF DDR_CH1_PLL_DVDD TYPEC0_DP0_VDD_0V85 TYPEC0_DP0_VDDA_0V85 TYPEC1_DP1_VDD_0V85 TYPEC1_DP1_VDDA_0V85 MIPI_D/C_PHY0_VDD MIPI_D/C_PHY1_VDD PCIE20_SATA30_0_AVDD_0V85 PCIE20_SATA30_1_AVDD_0V85 PCIE20_SATA30_USB30_2_AVDD_0V85	-0.3	1.00	V
1.2V supply voltage	MIPI_D/C_PHY0_VDD_1V2 MIPI_D/C_PHY1_VDD_1V2	-0.3	1.35	V
1.8V supply voltage	DDR_CH0_PLL_AVDD1V8 DDR_CH1_PLL_AVDD1V8 PLL_AVDD1V8 USB20_AVDD_1V8 TYPEC0_DP0_VDDH_1V8 TYPEC1_DP1_VDDH_1V8 HDMI/eDP_TX0_VDD_CMN_1V8 HDMI/eDP_TX0_VDD_IO_1V8 HDMI/eDP_TX1_VDD_CMN_1V8 HDMI/eDP_TX1_VDD_IO_1V8 MIPI_CSI0_AVCC1V8 MIPI_CSI1_AVCC1V8 MIPI_D/C_PHY0_VDD_1V8 MIPI_D/C_PHY1_VDD_1V8 PCIE20_SATA30_0_AVDD_1V8 PCIE20_SATA30_1_AVDD_1V8	-0.5	1.98	V

Parameters	Related Power Group	Min	Max	Unit
	PCIE20_SATA30_USB30_2_AVDD_1V8 PCIE30_PORT0_AVDD1V8 PCIE30_PORT1_AVDD1V8 SARADC_AVDD_1V8 OSC_1V8			
3.3V supply voltage	USB20_AVDD_3V3 HDMI_RX_DVDD3V3 HDMI_RX_VPH3V3	-0.5	3.63	V
1.8V only GPIO supply voltage	PMUIO1_1V8 EMMCIO_1V8 VCCIO1_1V8 VCCIO3_1V8	-0.5	1.98	V
1.8V/3.3V GPIO supply voltage	PMUIO2_1V8 VCCIO2_1V8 VCCIO4_1V8 VCCIO5_1V8 VCCIO6_1V8	-0.5	3.63	V
Supply voltage for DDR IO (LPDDR4/4X 0.6V; LPDDR5 0.5V)	DDR_CH0_VDDQ DDR_CH0_VDDQ_CK DDR_CH1_VDDQ DDR_CH1_VDDQ_CK	-0.3	0.7	V
Supply voltage for DDR IO (LPDDR4/4X 1.1V; LPDDR5 1.05V)	DDR_CH0_VDDQ_CKE DDR_CH1_VDDQ_CKE	-0.3	1.25	V
Storage Temperature	Tstg	-40	125	°C
Max Conjunction Temperature	Tj	NA	125	°C

3.2 Recommended Operating Conditions

The following table describes the recommended operating conditions.

Table 3-2 Recommended operating conditions

Parameters	Symbol	Min	Typ	Max ^③	Unit
Voltage for CPU BigCore 0 & memory	VDD_CPU_BIG0 & VDD_CPU_BIG0_MEM	0.675	0.75	0.95	V
Voltage for CPU BigCore 1 & memory	VDD_CPU_BIG1 & VDD_CPU_BIG1_MEM	0.675	0.75	0.95	V
Voltage for CPU LitCore and DSU	VDD_CPU_LIT & VDD_CPU_LIT_MEM	0.675	0.75	0.95	V
Voltage for GPU & memory	VDD_GPU & VDD_GPU_MEM	0.675	0.75	0.95	V
Voltage for NPU & memory	VDD_NPU & VDD_NPU_MEM	0.675	0.75	0.95	V
Voltage for VCODEC & memory	VDD_VDENC	0.675	0.75	0.825	V
Voltage for Logic	VDD_LOGIC	0.65	0.75	0.8	V
Voltage for PMU	PMU_0V75	0.7	0.75	0.8	V
Digital GPIO Power (1.8V only)	PMUIO1_1V8, VCCIO1_1V8, VCCIO3_1V8	1.65	1.8	1.89	V
Digital GPIO Power (3.3V/1.8V)	PMUIO2_1V8, VCCIO2_1V8, VCCIO4_1V8, VCCIO5_1V8, VCCIO6_1V8	2.7 1.65	3.3 1.8	3.6 1.95	V
eMMC IO Power (1.8V)	EMMCIO_1V8	1.65	1.8	1.89	V
DDR CH0 Logic power(0.85V)	DDR_CH0_VDD, DDR_CH0_VDD_MIF, DDR_CH1_VDD, DDR_CH1_VDD_MIF,	0.675	0.85	0.935	V
DDR CH0_PLL power(0.85V)	DDR_CH0_PLL_DVDD, DDR_CH1_PLL_DVDD	0.675	0.85	0.8925	V
DDR CH0_PLL power(1.8V)	DDR_CH0_PLL_AVDD1V8, DDR_CH1_PLL_AVDD1V8	1.62	1.8	1.89	V
LPDDR4 IO VDDQ power	DDR_CH0_VDDQ, DDR_CH0_VDDQ_CK, DDR_CH1_VDDQ, DDR_CH1_VDDQ_CK	0.57	0.6	0.63	V
LPDDR4 Retention IO VDDQ Power	DDR_CH0_VDDQ_CKE, DDR_CH1_VDDQ_CKE	1.045	1.1	1.155	V
LPDDR5 IO VDDQ power	DDR_CH0_VDDQ, DDR_CH0_VDDQ_CK, DDR_CH1_VDDQ, DDR_CH1_VDDQ_CK	0.475	0.5	0.525	V
LPDDR5 Retention IO VDDQ Power	DDR_CH0_VDDQ_CKE, DDR_CH1_VDDQ_CKE	1.0	1.05	1.1	V
PLL Analog Power(0.75V)	PLL_DVDD0V75	0.675	0.75	0.8925	V

Parameters	Symbol	Min	Typ	Max ^③	Unit
PLL Analog Power(1.8V)	PLL_AVDD1V8	1.62	1.8	1.89	V
USB 2.0 Analog Power (0.75V)	USB20_DVDD_0V75	0.6975	0.75	0.825	V
USB 2.0 Analog Power (1.8V)	USB20_AVDD_1V8	1.674	1.8	1.89	V
USB 2.0 Analog Power (3.3V)	USB20_AVDD_3V3	3.069	3.3	3.63	V
USB & DP Analog Power (0.85V)	TYPECO_DP0_VDD_0V85, TYPECO_DP0_VDDA_0V85, TYPEPC1_DP1_VDD_0V85, TYPEPC1_DP1_VDDA_0V85	0.8075	0.85	0.8925	V
USB & DP Analog Power (1.8V)	TYPECO_DP0_VDDH_1V8, TYPEPC1_DP1_VDDH_1V8	1.71	1.8	1.89	V
Combo PIPE PHY Analog Power(0.85V)	PCIE20_SATA30_0_AVDD_0V85, PCIE20_SATA30_1_AVDD_0V85, PCIE20_SATA30_USB30_2_AVDD_0V85	0.8	0.85	0.935	V
Combo PIPE PHY Analog Power(1.8V)	PCIE20_SATA30_0_AVDD_1V8, PCIE20_SATA30_1_AVDD_1V8, PCIE20_SATA30_USB30_2_AVDD_1V8	1.62	1.8	1.89	V
PCIe30 Analog Power(0.75V)	PCIE30_PORT0_AVDD0V75, PCIE30_PORT1_AVDD0V75	0.7125	0.75	0.8925	V
PCIe30 Analog Power(1.8V)	PCIE30_PORT0_AVDD1V8, PCIE30_PORT1_AVDD1V8	1.71	1.8	1.89	V
MIPI CSI DPHY Analog Power(0.75V)	MIPI_CSI0_AVCC0V75, MIPI_CSI1_AVCC0V75	0.675	0.75	0.825	V
MIPI CSI DPHY Analog Power(1.8V)	MIPI_CSI0_AVCC1V8, MIPI_CSI1_AVCC1V8	1.62	1.8	1.89	V
MIPI DCPHY Analog Power (0.85V)	MIPI_D/C_PHY0_VDD, MIPI_D/C_PHY1_VDD	0.7125	0.85	0.8925	V
MIPI DCPHY Analog Power (1.2V)	MIPI_D/C_PHY0_VDD_1V2, MIPI_D/C_PHY1_VDD_1V2	1.14	1.2	1.26	V
MIPI DCPHY Analog Power (1.8V)	MIPI_D/C_PHY0_VDD_1V8, MIPI_D/C_PHY1_VDD_1V8	1.71	1.8	1.89	V
HDMI RX Analog Power(0.75V)	HDMI_RX_AVDD0V75	0.675	0.75	0.825	V
HDMI RX Analog Power(3.3V)	HDMI_RX_DVDD3V3	3.135	3.3	3.465	V
HDMI RX Analog Power(3.3V)	HDMI_RX_VPH3V3	3.135	3.3	3.465	V
HDMI/eDP TX Digital Power (0.75V)	HDMI/eDP_TX0_VDD_0V75, HDMI/eDP_TX1_VDD_0V75	0.675	0.75	0.85	V
HDMI/eDP TX Analog Power (0.75V)	HDMI/eDP_TX0_AVDD_0V75, HDMI/eDP_TX1_AVDD_0V75	0.675	0.75	0.85	V
HDMI/eDP TX Analog Power (1.8V)	HDMI/eDP_TX0_VDD_CMN_1V8, HDMI/eDP_TX1_VDD_CMN_1V8	1.62	1.8	1.89	V
HDMI/eDP TX Analog Power (1.8V)	HDMI/eDP_TX0_VDD_IO_1V8, HDMI/eDP_TX1_VDD_IO_1V8	1.62	1.8	1.89	V
SARADC Analog Power(1.8V)	SARADC_AVDD_1V8	1.62	1.8	1.89	V
OTP Analog Power(0.75V)	OTP_VDDOTP_0V75	0.675	0.75	0.825	V
OSC Analog Power(1.8V)	OSC_1V8	1.65	1.8	1.95	V
OSC input clock frequency		NA	24	NA	MHz
Max CPU A76 frequency, normal mode ^①		NA	NA	1.6	GHz
Max CPU A76 frequency, overdrive mode ^②		NA	NA	2.0	GHz
Max CPU A55 frequency, normal mode ^①		NA	NA	1.3	GHz
Max CPU A55 frequency, overdrive mode ^②		NA	NA	1.7	GHz
Max GPU frequency, normal mode ^①		NA	NA	700	MHz
Max GPU frequency, overdrive mode ^②		NA	NA	850	GHz
Max NPU frequency, normal mode ^①		NA	NA	800	MHz
Max NPU frequency, overdrive mode ^②		NA	NA	950	GHz
Ambient Operating Temperature ^①	T _A	-40	NA	85	°C

Notes:

- ① Normal mode means the chipset works under safety voltage and frequency. For the industrial environment, highly recommend to keep in normal mode, the lifetime is reasonably guaranteed.
- ② Overdrive mode brings higher frequency, and the voltage will increase accordingly. Under the overdrive mode for a long time, the chipset may shorten the lifetime, especially in high temperature condition.
- ③ Different working frequency correspond to different voltage, please strictly refer to the software configuration of SDK and the hardware reference design. Such as the max working voltage of CPU/GPU/NPU is 0.75V under the normal mode. The power ripple suggests to control under +/-5%.

3.3 DC Characteristics

Table 3-3 DC Characteristics

Parameters		Symbol	Min	Typ	Max	Unit
Digital 3.3V/1.8V GPIO @3.3V	Input Low Voltage	V _{IL}	VSS	NA	0.3*VDDO	V
	Input High Voltage	V _{IH}	0.7*VDDO	NA	VDDO	V
	Output Low Voltage	V _{OL}	VSS	NA	0.25*DVDD	V
	Output High Voltage	V _{OH}	0.75*DVDD	NA	DVDD	V
	Pullup Resistor	R _{RPU}	10	NA	100	Kohm
	Pulldown Resistor	R _{RPD}	10	NA	100	Kohm
Digital 3.3V/1.8V GPIO @1.8V	Input Low Voltage	V _{IL}	VSS	NA	0.3*VDDO	V
	Input High Voltage	V _{IH}	0.7*VDDO	NA	VDDO	V
	Output Low Voltage	V _{OL}	VSS	NA	0.25*DVDD	V
	Output High Voltage	V _{OH}	0.75*DVDD	NA	DVDD	V
	Pullup Resistor	R _{RPU}	10	NA	50	Kohm
	Pulldown Resistor	R _{RPD}	10	NA	50	Kohm
Digital 1.8V only GPIO @1.8V	Input Low Voltage	V _{IL}	VSS	NA	0.3*VDDO	V
	Input High Voltage	V _{IH}	0.7*VDDO	NA	VDDO	V
	Output Low Voltage	V _{OL}	VSS	NA	0.25*DVDD	V
	Output High Voltage	V _{OH}	0.75*DVDD	NA	DVDD	V
	Pullup Resistor	R _{RPU}	10	NA	50	Kohm
	Pulldown Resistor	R _{RPD}	10	NA	50	Kohm
eMMC IO @1.8V	Input Low Voltage	V _{IL}	VSS	NA	0.35*DVDD	V
	Input High Voltage	V _{IH}	0.65*DVDD	NA	DVDD	V
	Output Low Voltage	V _{OL}	VSS	NA	0.45	V
	Output High Voltage	V _{OH}	DVDD-0.45	NA	DVDD	V
	Pullup Resistor	R _{RPU}	10	NA	50	Kohm
	Pulldown Resistor	R _{RPD}	10	NA	50	Kohm
DDR IO	Input Low Voltage	V _{IL}	NA	NA	Vref-0.14	V
	Input High Voltage	V _{IH}	Vref+0.14	NA	NA	V
	Output Log Voltage	V _{OL}	NA	NA	0.2	V
	Output High Voltage	V _{OH}	0.25	NA	NA	V
	Input Low Current	I _{IL}	-100/-500	NA	100/500	Room/Hot uA
	Input High Current	I _{IH}	-100/-500	NA	100/500	Room/Hot uA

Note: VDDO and DVDD are both IO power Supply

3.4 Electrical Characteristics for General IO

Table 3-4 Electrical Characteristics for Digital General IO

Parameters		Symbol	Test condition	Min	Typ	Max	Unit
Digital 3.3V/1.8V	Input leakage current	I _{PAD}	DVDD=Max, V _{PAD} =0V or DVDD	-10	NA	10	uA

Parameters		Symbol	Test condition	Min	Typ	Max	Unit
GPIO @3.3V	Input Hysteresis for Schmitt Trigger Operation	V_H		0.08* VDDO	NA	NA	V
	Input pullup resistor current	I_{RPU}	$V_{PAD} = 0V$	-20	NA	-180	μA
	Input pulldown resistor current	I_{RPD}	$V_{PAD} = VDDO$	20	NA	180	μA
Digital 3.3V/1.8V GPIO @1.8V	Input leakage current	I_{PAD}	DVDD=Max, $V_{PAD}=0V$ or DVDD	-10	NA	10	μA
	Input Hysteresis for Schmitt Trigger Operation	V_H		0.1* VDDO	NA	NA	V
	Input pullup resistor current	I_{RPU}	$V_{PAD} = 0V$	-20	NA	-180	μA
	Input pulldown resistor current	I_{RPD}	$V_{PAD} = VDDO$	20	NA	180	μA
Digital 1.8V only GPIO @1.8V	Input leakage current	I_{PAD}	DVDD=Max, $V_{PAD}=0V$ or DVDD	-10	NA	10	μA
	Input Hysteresis for Schmitt Trigger Operation	V_H		0.1* VDDO	NA	NA	V
	Input pullup resistor current	I_{RPU}	$V_{PAD} = 0V$	-20	NA	-170	μA
	Input pulldown resistor current	I_{RPD}	$V_{PAD} = VDDO$	20	NA	170	μA
eMMC IO @1.8V	Input leakage current	I_{PAD}	DVDD=Max, $V_{PAD}=0V$ or DVDD	-10	NA	10	μA
	Input Hysteresis for Schmitt Trigger Operation	V_H		0.1* DVDD	NA	NA	V
	Input pullup resistor current	I_{RPU}	$V_{PAD} = 0V$	-20	NA	-170	μA
	Input pulldown resistor current	I_{RPD}	$V_{PAD} = VDDO$	20	NA	170	μA

Note: VDDO and DVDD are both IO power Supply

3.5 Electrical Characteristics for PLL

Table 3-5 Electrical Characteristics for INT PLL

Parameters	Symbol	Test condition	Min	Typ	Max	Unit
Input clock frequency	F_{FIN}		4.5	-	300	MHz
Reference frequency(F_{FIN}/p)	F_{FREE}		4.5	7	12	MHz
Frequency of PLL's output	F_{FOUT}		35.2	-	4500	MHz
Frequency of VCO's output	F_{VCO}		2250	-	4500	MHz
Lock time	T_{LT}	Measured at all F_{FIN} and F_{FOUT} range. RESETB=High	-	-	150	Cycles

Table 3-6 Electrical Characteristics for FRAC PLL

Parameters	Symbol	Test condition	Min	Typ	Max	Unit
Input clock frequency	F_{FIN}		6	-	300	MHz
Reference frequency(F_{FIN}/p)	F_{FREE}		6	20	30	MHz
Frequency of PLL's output	F_{FOUT}		35.2	-	4500	MHz
Frequency of VCO's output	F_{VCO}		2250	-	4500	MHz
Lock time	T_{LT}	Measured at all F_{FIN} and F_{FOUT} range. RESETB=High	-	-	500	Cycles

Table 3-7 Electrical Characteristics for DDR PLL

Parameters	Symbol	Test condition	Min	Typ	Max	Unit
Input clock frequency	F_{FIN}		6	-	300	MHz
Reference frequency(F_{FIN}/p)	F_{FREE}		6	20	30	MHz
Frequency of PLL's output	F_{FOUT}		51.6	-	6600	MHz
Frequency of VCO's output	F_{VCO}		3300	-	6600	MHz
Lock time	T_{LT}	Measured at all F_{FIN} and F_{FOUT} range. RESETB=High	-	-	500	Cycles

Notes:

- ① p is the input divider value

3.6 Electrical Characteristics for PCIe2/SATA Interface

Table 3-8 Electrical Characteristics for PCIe2/SATA Interface

Parameters	Symbol	Min	Typ	Max	Unit
Transmitter					
Differential Peak-Peak TX Output Voltage Swing	V _{TX_DIFF_PP}	800	1000	1200	mV
Differential Peak-Peak Low Power TX Output Voltage Swing	V _{TX_DIFF_PP_LOW}	400	NA	1200	mV
The output impedance	R _{TX_DIFF_DC}	80	100	120	ohm
Single Ended Output Resistance Matching	R _{TX_DC_OFFSET}	NA	NA	5	%
Transmitter output common mode voltage	V _{TX_DC_CM}	400	NA	800	mV
Maximum mismatch between TXP and TXM for both time and amp	V _{TX_CM_AC_PP_ACTIVE}	NA	NA	50	mV
The amount of voltage change allowed during Receiver Detection	V _{TX_RCV_DETECT}	NA	NA	600	mV
TX de-emphasis	V _{TX_DE_RATIO}	3.0	3.5	4.0	dB
AC Coupling Capacitor(USB3.1/PCIe)	C _{AC_COUPLING}	75	NA	200	nF
AC Coupling Capacitor(SATA)		6	NA	12	nF
Output rising time for 20% to 80%	T _r	25	NA	NA	ps
Output falling time for 20% to 80%	T _f	25	NA	NA	ps
Transmitter short circuit limit	I _{TX_SHORT}	NA	NA	20	mA
Output differential skew	T _{SKEW_DIFF}	-15	NA	15	ps
Receiver					
Input Voltage Swing	V _{RXDPP_C}	250	NA	1200	mVpp
The input differential impedance	R _{RXD_C}	80	100	120	Ohm
Single Ended input Resistance Matching	R _{RXD_C_MS}	NA	NA	5	%

3.7 Electrical Characteristics for MIPI CDPHY interface

Table 3-9 Electrical Characteristics for MIPI CDPHY interface

Parameters	Symbol	Description	Test condition	Min	Typ	Max	Unit
LP-RX	V _{IH}	Logic1 input voltage	All conditions	880	NA	NA	mV
	V _{IL}	Logic0 input voltage, not in ULPS state	All conditions	NA	NA	550	mV
Skew Calibration	T _{skewcal (initial)}	Duration for which the transmitter drives the skew-calibration pattern in the initial skew calibration mode	> 1.5Gbps	NA	NA	100	us
				2 [^] 15	NA	NA	UI
	T _{skewcal (periodic)}	Duration for which the transmitter drives the skew-calibration pattern in the periodic skew calibration mode	> 1.5Gbps (optional)	NA	NA	10	us
				2 [^] 13	NA	NA	UI

3.8 Electrical Characteristics for MIPI CSI DPHY interface

Table 3-10 Electrical Characteristics for MIPI CSI DPHY interface

Parameters	Symbol	Min	Typ	Max	Units
Common-mode interference beyond 450 MHz	ΔVCMRX(HF)	NA	NA	100	mV
		NA	NA	50	mV
Common-mode interference 50MHz-450MHz	ΔVCMRX(LF)	-50	NA	50	mV
		-25	NA	25	mV
Common-mode termination	CCM	NA	NA	60	pF
Input pulse rejection	eSPIKE	NA	NA	300	V.ps
Minimum pulse width response	TMIN-RX	20	NA	NA	ns
Peak interference amplitude	VINT	NA	NA	200	mV
Interference frequency	fINT	450	NA	NA	MHz

3.9 Electrical Characteristics for SARADC

Table 3-101 Electrical Characteristics for SARADC

Parameters	Symbol	Test condition	Min	Typ	Max	Unit
Resolution			NA	12	NA	Bit
Anglog Input Range	AIN		AVSS18	NA	AVDD18	V
Differential Non-Linearity	DNL	PD = Low	NA	±1.0	±3.0	LSB

Parameters	Symbol	Test condition	Min	Typ	Max	Unit
Integral Non-Linearity	INL	$F_s = 1\text{MS/s}$ $F_{\text{CLK}} = 20\text{MHz}$ $F_{\text{SOC}} = 1\text{MHz}$ $F_{\text{AIN}} = 10\text{kHz ramp wave}$	NA	± 2.0	± 6.0	LSB
Top Offset Voltage Error	E_{OT}		NA	± 10	± 20	LSB
Bottom Offset Voltage Error	E_{OB}		NA	± 10	± 20	LSB

3.10 Electrical Characteristics for TSADC

Table 3-12 Electrical Characteristics for TSADC

Parameters	Symbol	Test condition	Min	Typ	Max	Unit
Accuracy from -40°C to 125°C	T_{JACC}	Temp: -40 ~ 125°C Supply: 1.62V ~ 1.98V	NA	± 3	± 5	°C
Sensing Temperature Range	T_{RANGE}		-40	NA	125	°C
Resolution	T_{LSB}		NA	1	NA	°C

Chapter 4 Thermal Management

4.1 Overview

For reliability and operability concerns, the absolute maximum junction temperature has to be below 125°C.

4.2 Package Thermal Characteristics

Table 4-1 provides the thermal resistance characteristics for the package used on the SoC. The resulting simulation data for reference only, please prevail in kind test.

Table 4-1 Thermal Resistance Characteristics

Parameter	Symbol	Typical	Unit
Junction-to-ambient thermal resistance	θ_{JA}	8.7	(°C/W)
Junction-to-board thermal resistance	θ_{JB}	3.5	(°C/W)
Junction-to-case thermal resistance	θ_{JC}	0.12	(°C/W)

Note: The testing PCB is 10 layers, 114mmx101mm, Ambient temperature is 25°C.