

General Description

The AO6400 uses advanced trench technology to provide excellent $R_{DS(ON)}$, low gate charge and operation with gate voltages as low as 2.5V. This device is suitable for use as a load switch or in PWM applications.

Product Summary

V_{DS}	30V
I_D (at $V_{GS}=10V$)	6.9A
$R_{DS(ON)}$ (at $V_{GS}=10V$)	< 28m Ω
$R_{DS(ON)}$ (at $V_{GS} = 4.5V$)	< 33m Ω
$R_{DS(ON)}$ (at $V_{GS} = 2.5V$)	< 52m Ω

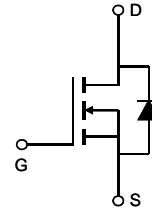
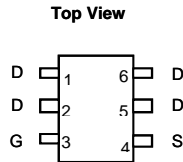
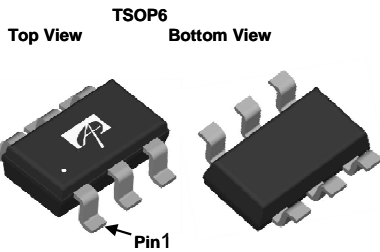

Absolute Maximum Ratings $T_A=25^\circ\text{C}$ unless otherwise noted

Parameter	Symbol	Maximum	Units
Drain-Source Voltage	V_{DS}	30	V
Gate-Source Voltage	V_{GS}	± 12	V
Continuous Drain Current	I_D	$T_A=25^\circ\text{C}$	6.9
		$T_A=70^\circ\text{C}$	5.8
Pulsed Drain Current ^C	I_{DM}	35	A
Power Dissipation ^B	P_D	$T_A=25^\circ\text{C}$	2
		$T_A=70^\circ\text{C}$	1.3
Junction and Storage Temperature Range	T_J, T_{STG}	-55 to 150	$^\circ\text{C}$

Thermal Characteristics

Parameter	Symbol	Typ	Max	Units
Maximum Junction-to-Ambient ^A	$R_{\theta JA}$	47.5	62.5	$^\circ\text{C/W}$
Maximum Junction-to-Ambient ^{A,D}		Steady-State	74	110
Maximum Junction-to-Lead	$R_{\theta JL}$	37	50	$^\circ\text{C/W}$

Electrical Characteristics (T_J=25°C unless otherwise noted)

Symbol	Parameter	Conditions	Min	Typ	Max	Units
STATIC PARAMETERS						
BV _{DSS}	Drain-Source Breakdown Voltage	I _D =250μA, V _{GS} =0V	30			V
I _{DSS}	Zero Gate Voltage Drain Current	V _{DS} =30V, V _{GS} =0V T _J =55°C			1 5	μA
I _{GSS}	Gate-Body leakage current	V _{DS} =0V, V _{GS} = ±12V			100	nA
V _{GS(th)}	Gate Threshold Voltage	V _{DS} =V _{GS} I _D =250μA	0.65	1.05	1.45	V
I _{D(ON)}	On state drain current	V _{GS} =4.5V, V _{DS} =5V	35			A
R _{DS(ON)}	Static Drain-Source On-Resistance	V _{GS} =10V, I _D =6.9A T _J =125°C		18 28	28 39	mΩ
		V _{GS} =4.5V, I _D =6A		19	33	
		V _{GS} =2.5V, I _D =5A		24	52	
g _{FS}	Forward Transconductance	V _{DS} =5V, I _D =6.9A		33		S
V _{SD}	Diode Forward Voltage	I _S =1A, V _{GS} =0V		0.7	1	V
I _S	Maximum Body-Diode Continuous Current				2	A
DYNAMIC PARAMETERS						
C _{iss}	Input Capacitance	V _{GS} =0V, V _{DS} =15V, f=1MHz		630		pF
C _{oss}	Output Capacitance			75		pF
C _{rss}	Reverse Transfer Capacitance			50		pF
R _g	Gate resistance	V _{GS} =0V, V _{DS} =0V, f=1MHz	1.5	3	4.5	Ω
SWITCHING PARAMETERS						
Q _g	Total Gate Charge	V _{GS} =4.5V, V _{DS} =15V, I _D =6.9A		6	7	nC
Q _{gs}	Gate Source Charge			1.3		nC
Q _{gd}	Gate Drain Charge			1.8		nC
t _{D(on)}	Turn-On DelayTime	V _{GS} =10V, V _{DS} =15V, R _L =2.2Ω, R _{GEN} =3Ω		3		ns
t _r	Turn-On Rise Time			2.5		ns
t _{D(off)}	Turn-Off DelayTime			25		ns
t _f	Turn-Off Fall Time			4		ns
t _{rr}	Body Diode Reverse Recovery Time	I _F =6.9A, di/dt=100A/μs		8.5		ns
Q _{rr}	Body Diode Reverse Recovery Charge	I _F =6.9A, di/dt=100A/μs		2.6		nC

A. The value of R_{θJA} is measured with the device mounted on 1in² FR-4 board with 2oz. Copper, in a still air environment with T_A=25° C. The value in any given application depends on the user's specific board design.

B. The power dissipation P_D is based on T_{J(MAX)}=150° C, using ≤ 10s junction-to-ambient thermal resistance.

C. Repetitive rating, pulse width limited by junction temperature T_{J(MAX)}=150° C. Ratings are based on low frequency and duty cycles to keep initial T_J=25° C.

D. The R_{θJA} is the sum of the thermal impedance from junction to lead R_{θJL} and lead to ambient.

E. The static characteristics in Figures 1 to 6 are obtained using <300μs pulses, duty cycle 0.5% max.

F. These curves are based on the junction-to-ambient thermal impedance which is measured with the device mounted on 1in² FR-4 board with 2oz. Copper, assuming a maximum junction temperature of T_{J(MAX)}=150° C. The SOA curve provides a single pulse rating.

THIS PRODUCT HAS BEEN DESIGNED AND QUALIFIED FOR THE CONSUMER MARKET. APPLICATIONS OR USES AS CRITICAL COMPONENTS IN LIFE SUPPORT DEVICES OR SYSTEMS ARE NOT AUTHORIZED. AOS DOES NOT ASSUME ANY LIABILITY ARISING OUT OF SUCH APPLICATIONS OR USES OF ITS PRODUCTS. AOS RESERVES THE RIGHT TO IMPROVE PRODUCT DESIGN, FUNCTIONS AND RELIABILITY WITHOUT NOTICE.

TYPICAL ELECTRICAL AND THERMAL CHARACTERISTICS

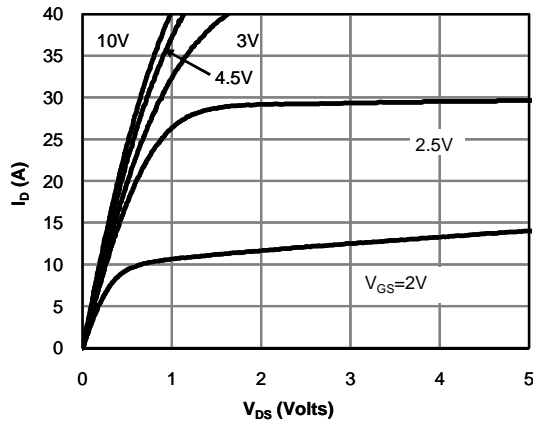

Fig 1: On-Region Characteristics (Note E)

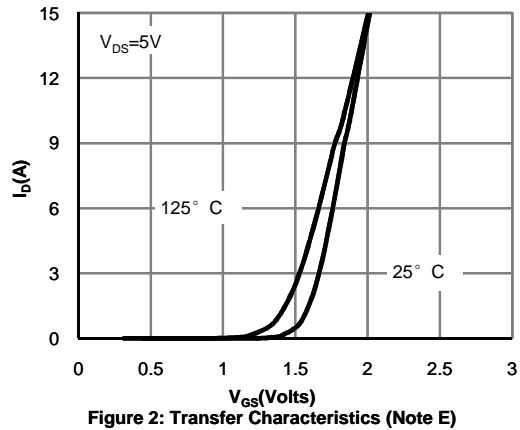

Figure 2: Transfer Characteristics (Note E)

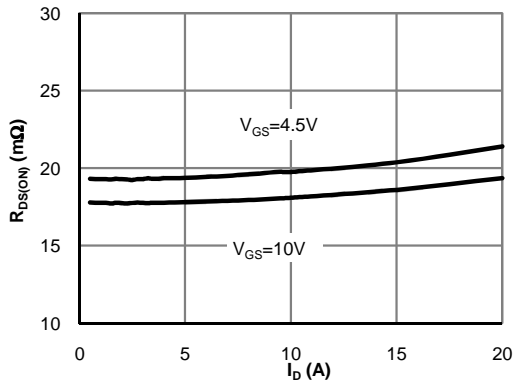

Figure 3: On-Resistance vs. Drain Current and Gate Voltage (Note E)

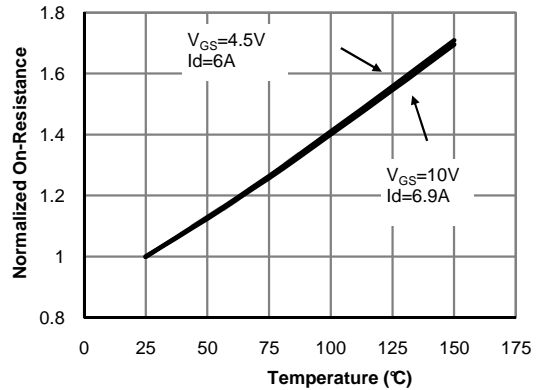

Figure 4: On-Resistance vs. Junction Temperature (Note E)

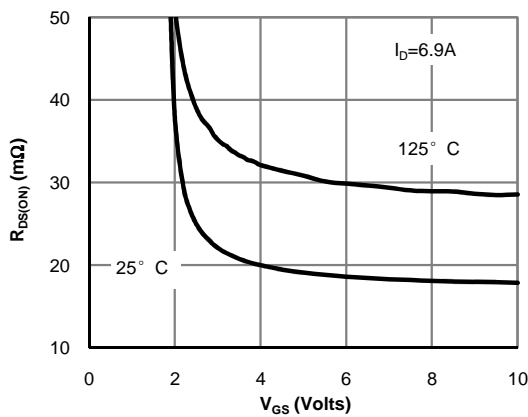

Figure 5: On-Resistance vs. Gate-Source Voltage (Note E)

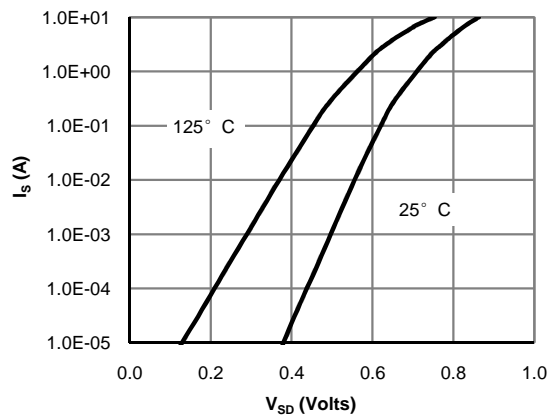

Figure 6: Body-Diode Characteristics (Note E)

TYPICAL ELECTRICAL AND THERMAL CHARACTERISTICS

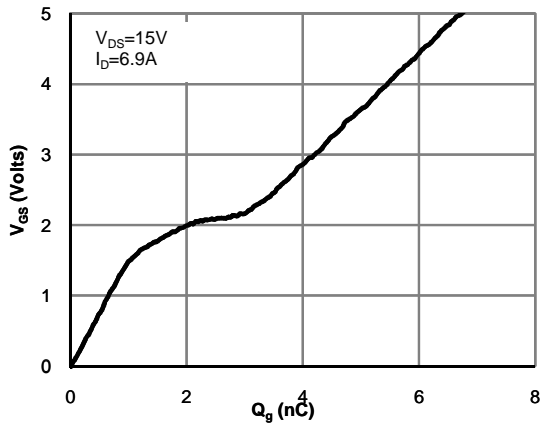

Figure 7: Gate-Charge Characteristics

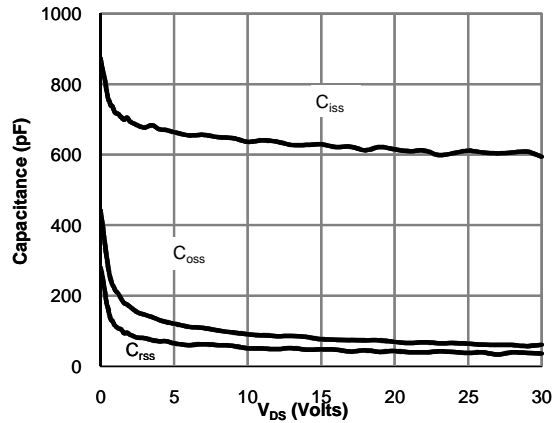

Figure 8: Capacitance Characteristics

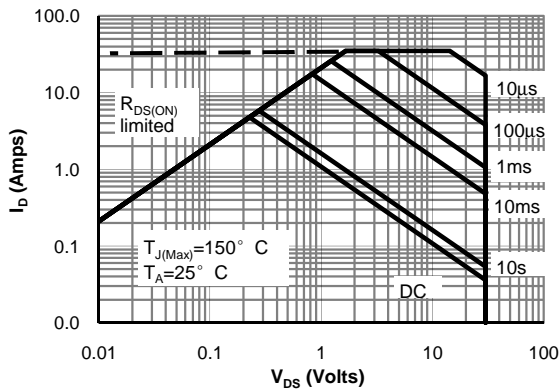

Figure 9: Maximum Forward Biased Safe Operating Area (Note F)

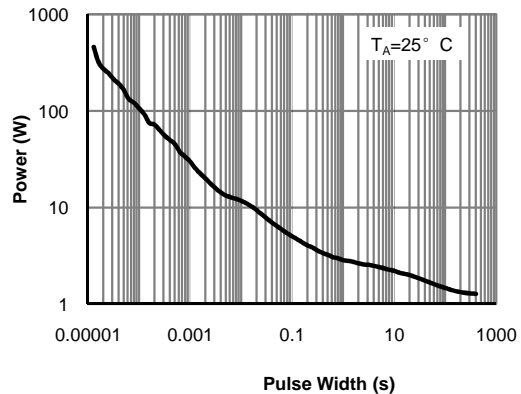

Figure 10: Single Pulse Power Rating Junction-to-Ambient (Note F)

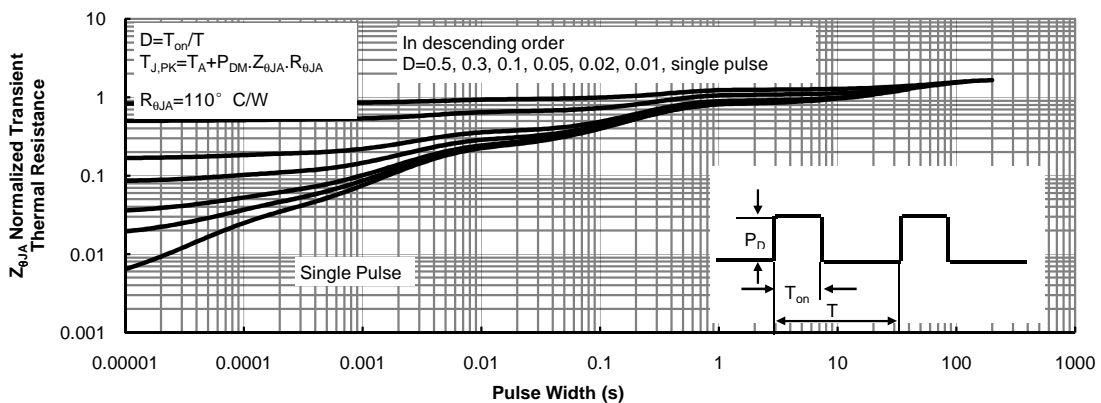
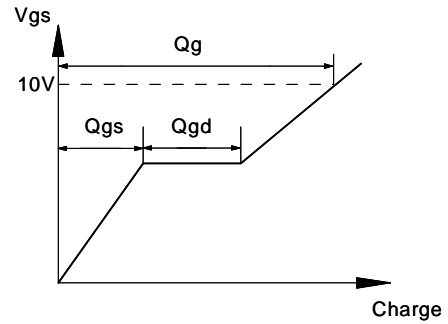
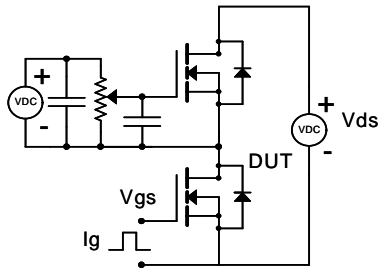
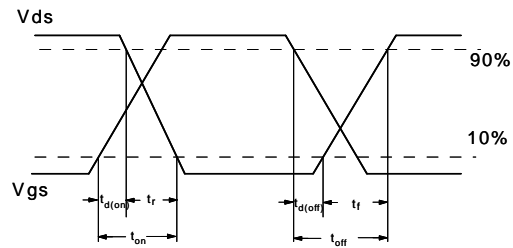
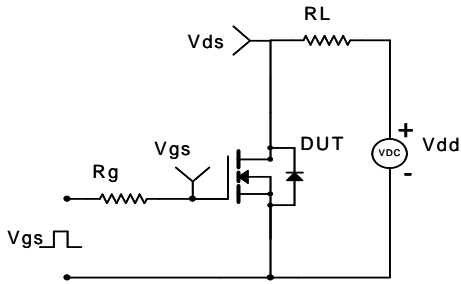

Figure 11: Normalized Maximum Transient Thermal Impedance (Note F)

Gate Charge Test Circuit & Waveform



Resistive Switching Test Circuit & Waveforms



Diode Recovery Test Circuit & Waveforms

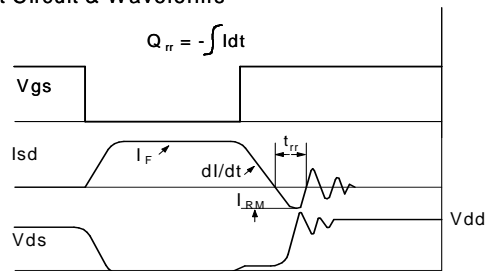
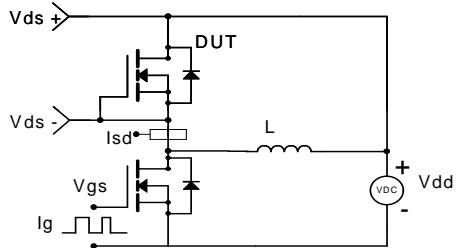



Document No.	PD-00098
Version	F
Title	AO6400 Marking Description

TSOP-6 PACKAGE MARKING DESCRIPTION

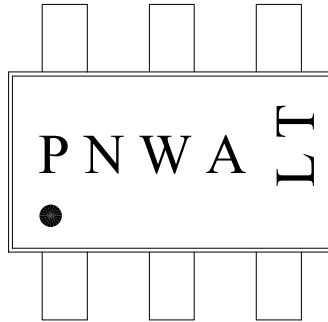

Green product

NOTE:

- PN - Part number code
- W - Year and week code
- A - Assembly location code
- L&T - Assembly lot code

PART NO.	DESCRIPTION	CODE (PN)
AO6400	Green product	D0
AO6400L	Green product	D0

TSOP6 PACKAGE OUTLINE

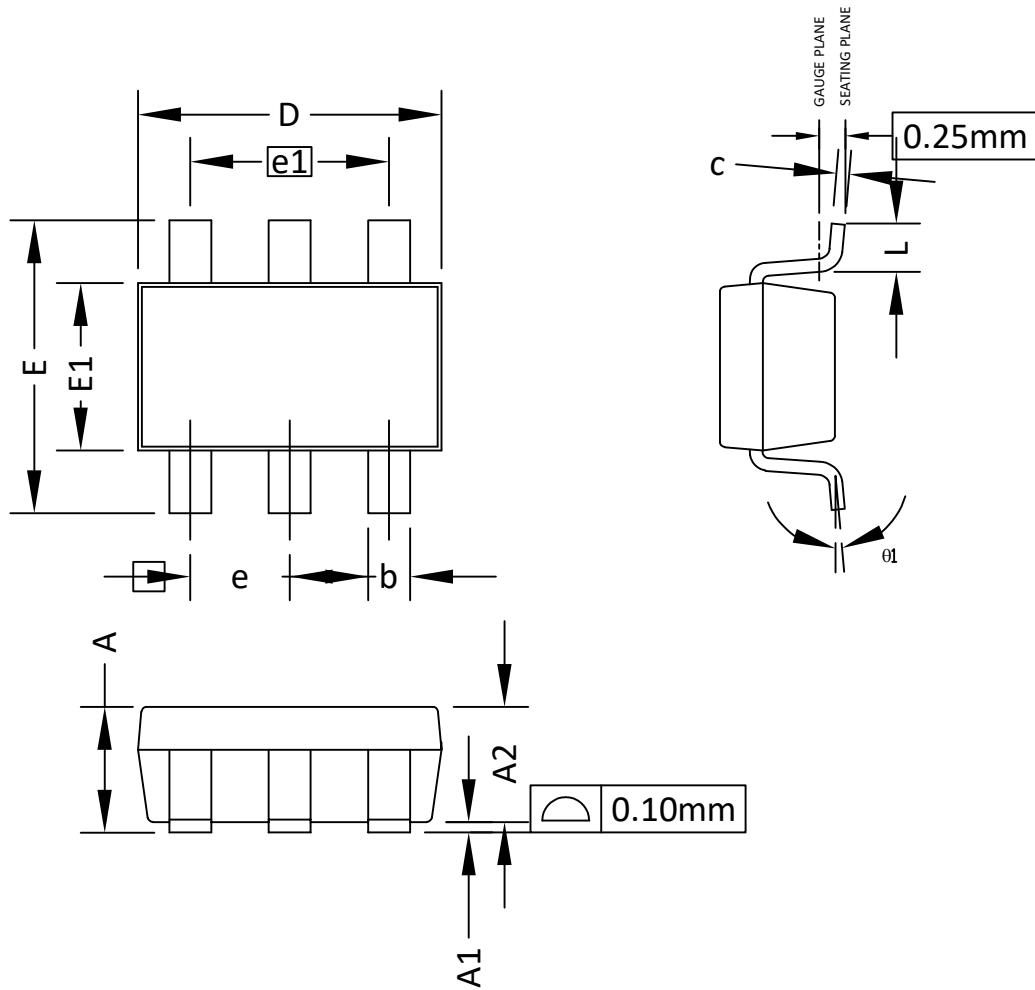

RECOMMENDED LAND PATTERN

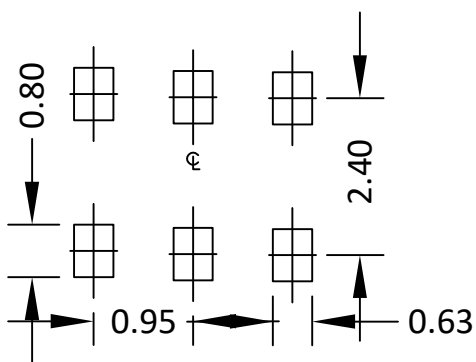

UNIT: mm

SYMBOLS	DIM. IN MM			DIM. IN INCH		
	MIN.	NOM.	MAX.	MIN.	NOM.	MAX.
A	0.800	---	1.250	0.031	---	0.049
A1	0.000	---	0.150	0.000	---	0.006
A2	0.700	1.100	1.200	0.028	0.043	0.047
b	0.300	0.400	0.500	0.012	0.016	0.020
c	0.080	0.130	0.200	0.003	0.005	0.008
D	2.700	2.900	3.100	0.106	0.114	0.122
E	2.500	2.800	3.100	0.098	0.110	0.122
E1	1.500	1.600	1.700	0.059	0.063	0.067
e	0.95BSC			0.37BSC		
e1	1.9BSC			0.075BSC		
L	0.300	---	0.600	0.012	---	0.024
$\theta 1$	0°	---	1.700	0°	---	0.067

NOTE

- PACKAGE BODY SIZES EXCLUDE MOLD FLASH AND GATE BURRS.
MOLD FLASH AT THE NON-LEAD SIDES SHOULD BE LESS THAN 5 MILS EACH.
- DIMENSION "L" IS MEASURED IN GAUGE PLANE.
- TOLERANCE ± 0.100 mm (4 mil) UNLESS OTHERWISE SPECIFIED.
- FOLLOWED FROM JEDEC MO-178C & MO-193C.
- CONTROLLING DIMENSIONS IS MILLIMETER.
CONVERTED INCH DIMENSIONS ARE NOT NECESSARILY EXACT.



ALPHA & OMEGA
SEMICONDUCTOR

AOS Semiconductor Product Reliability Report

AO6400/AO6400L, rev B

Plastic Encapsulated Device

ALPHA & OMEGA Semiconductor, Inc

**495 Mercury Drive
Sunnyvale, CA 94085
U.S.**

Tel: (408) 830-9742

www.aosmd.com

Jun 27, 2006

This AOS product reliability report summarizes the qualification result for AO6400. Accelerated environmental tests are performed on a specific sample size, and then followed by electrical test at end point. Review of final electrical test result confirms that AO6400 passes AOS quality and reliability requirements. The released product will be categorized by the process family and be monitored on a quarterly basis for continuously improving the product quality.

Table of Contents:

- I. Product Description
- II. Package and Die information
- III. Environmental Stress Test Summary and Result
- IV. Reliability Evaluation
- V. Quality Assurance Information

I. Product Description:

The AO6400 uses advanced trench technology to provide excellent $R_{DS(ON)}$, low gate charge and operation with gate voltages as low as 2.5V. This device is suitable for use as a load switch or in PWM applications. Standard product AO6400 is Pb-free (meets ROHS & Sony 259 specifications). AO6400 is a Green Product ordering option. AO6400 and AO6400L are electrically identical.

Absolute Maximum Ratings $T_A=25^\circ\text{C}$ unless otherwise noted				
Parameter		Symbol	Maximum	Units
Drain-Source Voltage		V_{DS}	30	V
Gate-Source Voltage		V_{GS}	± 12	V
Continuous Drain Current	$T_A=25^\circ\text{C}$	I_D	6.9	A
	$T_A=70^\circ\text{C}$		5.8	
Pulsed Drain Current		I_{DM}	35	
Power Dissipation	$T_A=25^\circ\text{C}$	P_D	2	W
	$T_A=70^\circ\text{C}$		1.44	
Junction and Storage Temperature Range		T_J, T_{STG}	-55 to 150	$^\circ\text{C}$

Thermal Characteristics					
Parameter		Symbol	Typ	Max	Units
Maximum Junction-to-Ambient	$T \leq 10\text{s}$	$R_{\theta JA}$	47.5	62.5	$^\circ\text{C/W}$
	Steady-State		74	110	$^\circ\text{C/W}$
Maximum Junction-to-Lead	Steady-State	$R_{\theta JL}$	37	50	$^\circ\text{C/W}$

II. Die / Package Information:

	AO6400	AO6400L (Green Compound)
Process	Standard sub-micron low voltage N channel process	Standard sub-micron low voltage N channel process
Package Type	6 leads TSOP	6 leads TSOP
Lead Frame	Copper with Ag spot	Copper with Ag spot
Die Attach	Ag epoxy	Ag epoxy
Bond wire	Au 2mils	Au 2mils
Mold Material	Epoxy resin with silica filler	Epoxy resin with silica filler
Filler % (Spherical/Flake)	90/10	100/0
Flammability Rating	UL-94 V-0	UL-94 V-0
Backside Metallization	Ti / Ni / Ag	Ti / Ni / Ag
Moisture Level	Up to Level 1 *	Up to Level 1 *

Note * based on info provided by assembler and mold compound supplier

III. Result of Reliability Stress for AO6400 (Standard) & AO6400L (Green)

Test Item	Test Condition	Time Point	Lot Attribution	Total Sample size	Number of Failures
Solder Reflow Precondition	Standard: 1hr PCT+3 cycle reflow @260°C Green: 168hr 85°C /85%RH +3 cycle reflow @260°C	0hr	Standard: 18 lots Green: 7 lots	3685pcs	0
HTGB	Temp = 150°C, Vgs=100% of Vgsmax	168 / 500 hrs 1000 hrs	9 lots (Note A*)	738pcs 77+5 pcs / lot	0
HTRB	Temp = 150°C , Vds=80% of Vdsmax	168 / 500 hrs 1000 hrs	9 lots (Note A*)	738pcs 77+5 pcs / lot	0
HAST	130 +/- 2°C , 85%RH, 33.3 psi, Vgs = 80% of Vgs max	100 hrs	Standard: 16 lots Green: 6 lots (Note B**)	1210pcs 50+5 pcs / lot	0
Pressure Pot	121°C , 15+/-1 PSIG, RH=100%	96 hrs	Standard: 13 lots Green: 7 lots (Note B**)	1100pcs 50+5 pcs / lot	0
Temperature Cycle	-65°C to 150°C , air to air,	250 / 500 cycles	Standard: 18 lots Green: 7 lots (Note B**)	1375pcs 50+5 pcs / lot	0

III. Result of Reliability Stress for AO6400 (Standard) & AO6400L (Green) Continues

DPA	Internal Vision Cross-section X-ray	NA	5 5 5	5 5 5	0
CSAM		NA	5	5	0
Bond Integrity	Room Temp 150°C bake 150°C bake	0hr 250hr 500hr	40 40 40	40 wires 40 wires 40 wires	0
Solderability	230°C	5 sec	15	15 leads	0
Die shear	150°C	0hr	10	10	0

Note A: The HTGB and HTRB reliability data presents total of available AO6400 and AO6400L burn-in data up to the published date.

Note B: The pressure pot, temperature cycle and HAST reliability data for AO6400 and AO6400L comes from the AOS generic package qualification data.

IV. Reliability Evaluation

FIT rate (per billion): 2.4

MTTF = 47564years

In general, 500 hrs of HTGB, 150 deg C accelerated stress testing is equivalent to 15 years of lifetime at 55 deg C operating conditions (by applying the Arrhenius equation with an activation energy of 0.7eV and 60% of upper confidence level on the failure rate calculation). AOS reliability group also routinely monitors the product reliability up to 1000 hr at and performs the necessary failure analysis on the units failed for reliability test(s).

The presentation of FIT rate for the individual product reliability is restricted by the actual burn-in sample size of the selected product (AO6400). Failure Rate Determination is based on JEDEC Standard JESD 85. FIT means one failure per billion hours.

$$\text{Failure Rate} = \text{Chi}^2 \times 10^9 / [2 (N) (H) (Af)] = 1.83 \times 10^9 / [2 (9 \times 164) (1000) (258)] = 2.4$$

$$\text{MTTF} = 10^9 / \text{FIT} = 4.16 \times 10^8 \text{hrs} = 47564 \text{years}$$

Chi² = Chi Squared Distribution, determined by the number of failures and confidence interval

N = Total Number of units from HTRB and HTGB tests

H = Duration of HTRB/HTGB testing

Af = Acceleration Factor from Test to Use Conditions (Ea = 0.7eV and Tuse = 55°C)

Acceleration Factor [**Af**] = $\text{Exp} [Ea / k (1/Tj u - 1/Tj s)]$

Acceleration Factor ratio list:

	55 deg C	70 deg C	85 deg C	100 deg C	115 deg C	130 deg C	150 deg C
Af	258	87	32	13	5.64	2.59	1

Tj s = Stressed junction temperature in degree (Kelvin), K = C+273.16

Tj u = The use junction temperature in degree (Kelvin), K = C+273.16

k = Boltzmann's constant, 8.617164 X 10⁻⁵eV / K

V. Quality Assurance Information

Acceptable Quality Level for outgoing inspection: **0.1%** for electrical and visual.

Guaranteed Outgoing Defect Rate: **< 25 ppm**

Quality Sample Plan: conform to **Mil-Std-105D**



TSOP-6 Carrier Tape

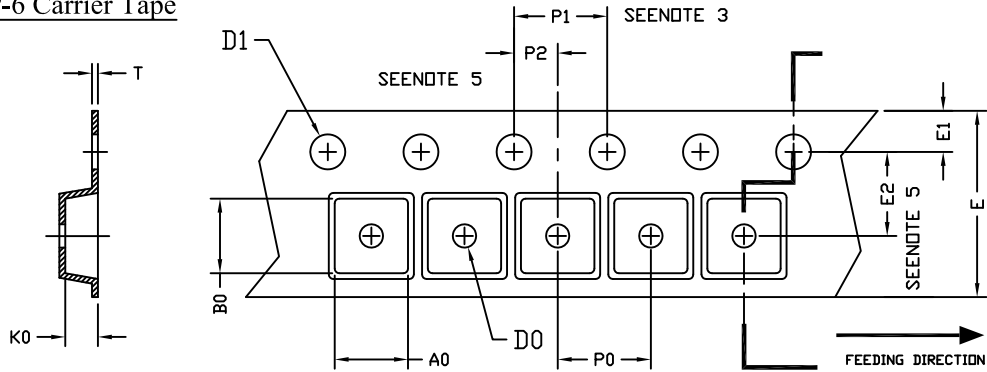

UNIT: MM

PACKAGE	A0	B0	K0	D0	D1	E	E1	E2	P0	P1	P2	T
SDT-23 (8 mm)	3.15 ±0.10	3.27 ±0.10	1.34 ±0.10	1.10 ±0.01	1.50 +0.10	8.00 ±0.20	1.75 ±0.10	3.50 ±0.05	4.00 ±0.10	4.00 ±0.10	2.00 ±0.10	0.25 ±0.05

TSOP-6 Reel

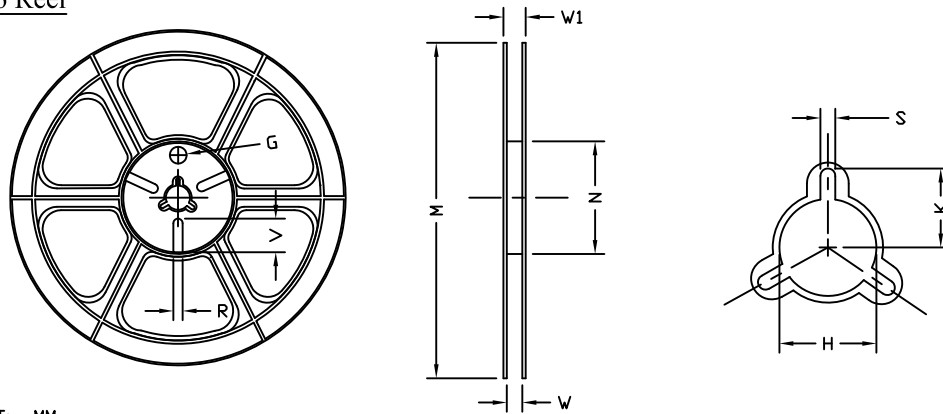

UNIT: MM

TAPE SIZE	REEL SIZE	M	N	W	W1	H	K	S	G	R	V
8 mm	Ø180	Ø180.00 ±0.50	Ø60.50	9.00 ±0.30	11.40 ±1.00	Ø13.00 +0.50 -0.20	10.60	2.00 ±0.50	Ø9.00	5.00	18.00

TSOP-6 Tape

Leader / Trailer & Orientation

Unit Per Reel:
3000pcs

