

Verpackt im Gurt in Anlehnung an DIN IEC 60286-3  
 tape on reel packaging according to DIN IEC 60286-3  
 Verpackungseinheit: 280 Stück  
 packaging unit: 280 pcs

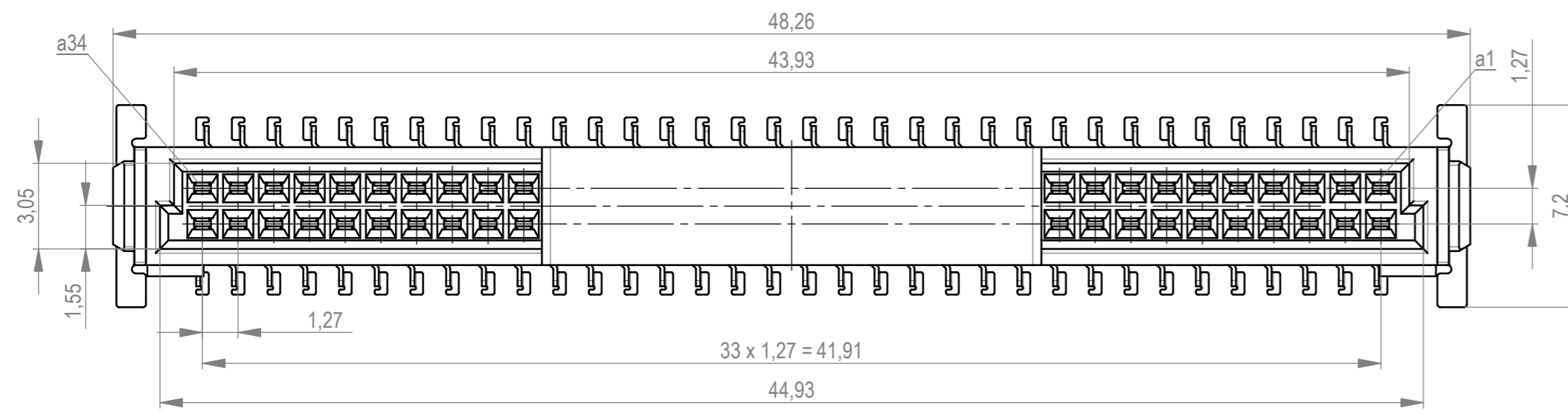

Abspulrichtung - reel off direction

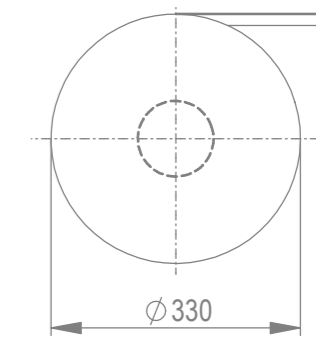
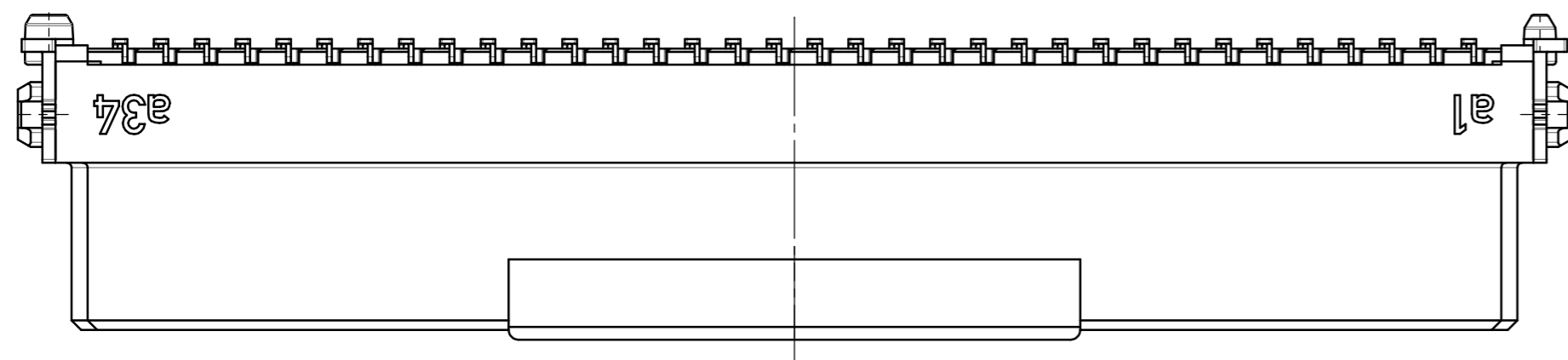
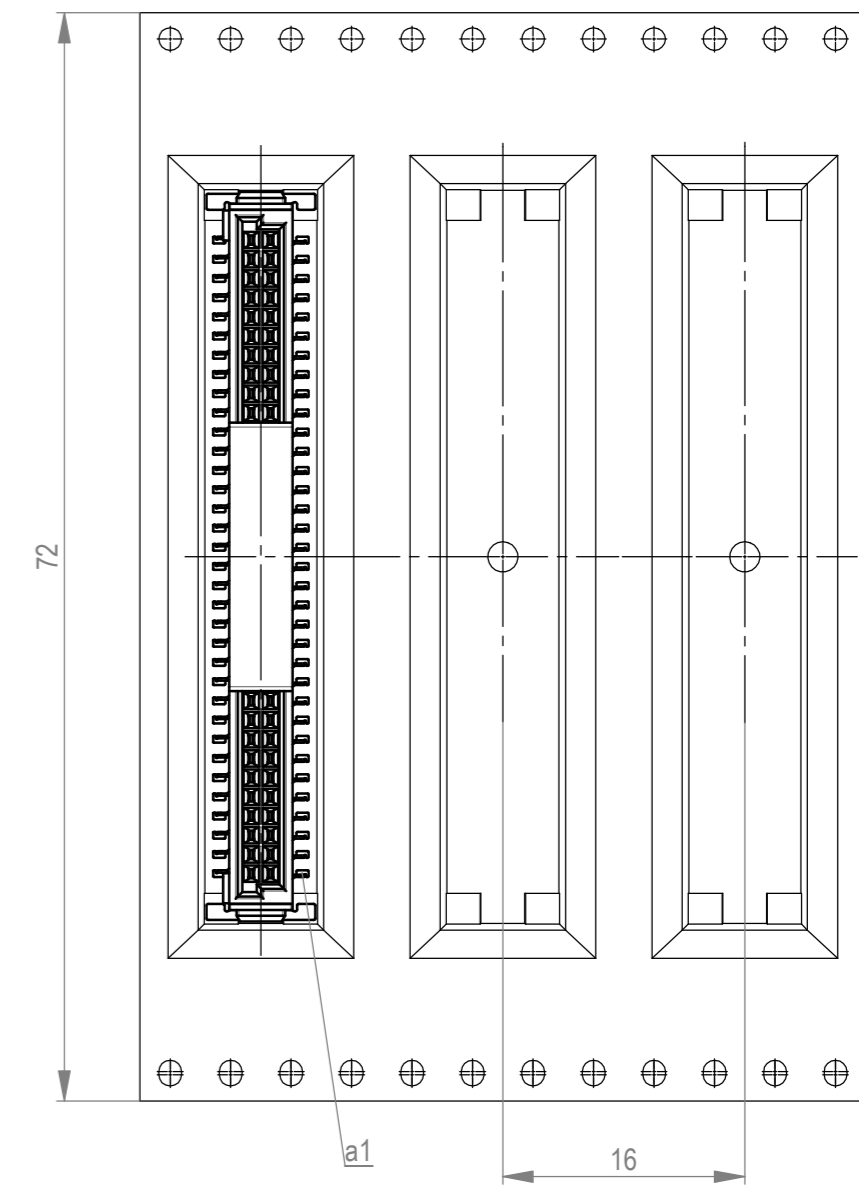

Leiterplatten-Layout Vorschlag für SMT  
 PCB-Layout Proposal for SMT

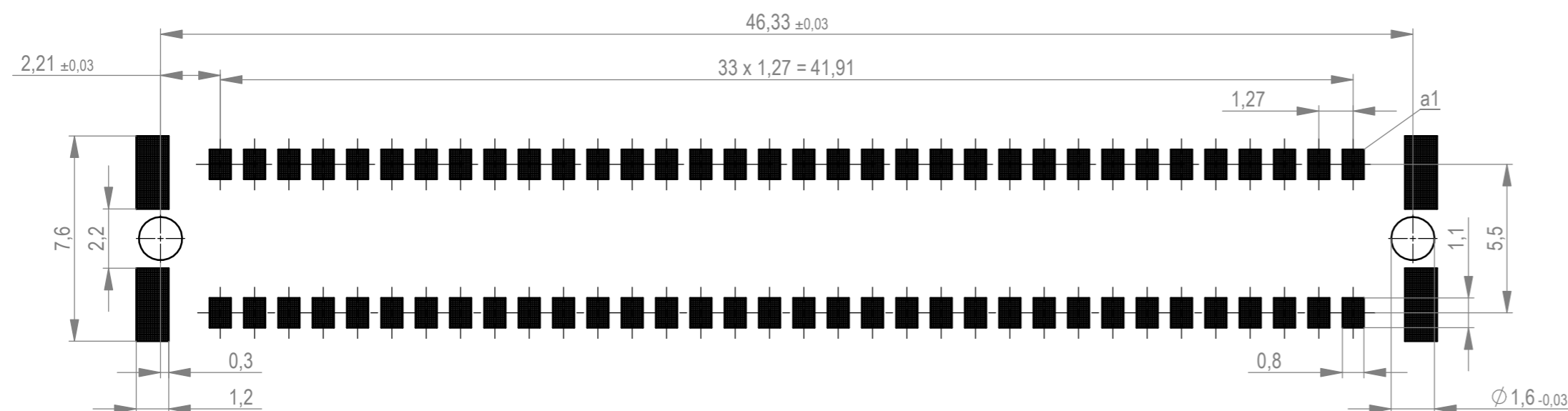

Anforderungsstufe 1  
 performance level 1

Kontaktbereich vergoldet  
 mating area gold plating

Anschlussbereich verzinkt 4-6 µm  
 terminal area 4-6 µm tin plating

Koplanarität der Anschlüsse ≤ 0,1 mm  
 coplanarity area of termination ≤ 0,1 mm

BA 7-03 - Standard Bauhöhe  
 type 7-03 - standard assembly height

Weder die deutsche Version dieser Zeichnung dient zur Erleichterung der Handhabung. Bei Abweichungen vom englischen Original gilt das englische Original. This drawing has been created for convenience only and may deviate from the original. In case of any deviation the English version shall prevail.

Dimension no.	Tolerances	Scale	5:1
	ISO 8015	Material	
Customer drawing:	Subject to modification without prior notice. Drawing will not be updated.		
This Drawing is a controlled Document.	<b>TE Connectivity</b>		<b>Federl. SMC-B 68-SMD-BA7-03</b> <b>Female SMC-B 68-SMD-type7-03</b> <b>C-154720-E</b>
f1	12.05.2023	Class	SMCB
Index	Date		