

Features

- N channel
- Enhancement mode
- Avalanche rated
- Logic Level
- dv/dt rated
- 175 °C operating temperature

Product Summary

Drain source voltage	V_{DS}	55	V
Drain-Source on-state resistance	$R_{DS(on)}$	0.015	Ω
Continuous drain current	I_D	47	A

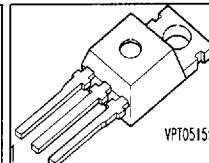
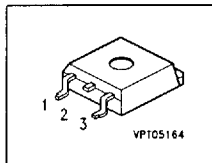

Type	Package	Ordering Code	Packaging
BUZ102SL	P-TO220-3-1	Q67040-S4010-A2	Tube
BUZ102SL E3045A	P-TO263-3-2	Q67040-S4010-A6	Tape and Reel
BUZ102SL E3045	P-TO263-3-2	Q67040-S4010-A5	Tube

Pin 1	Pin 2	Pin 3
G	D	S

Maximum Ratings, at $T_j = 25$ °C unless otherwise specified

Parameter	Symbol	Value	Unit
Continuous drain current $T_C = 25$ °C $T_C = 100$ °C	I_D	47 33	A
Pulsed drain current $T_C = 25$ °C	I_{Dpulse}	188	
Avalanche energy, single pulse $I_D = 47$ A, $V_{DD} = 25$ V, $R_{GS} = 25$ Ω	E_{AS}	245	mJ
Avalanche energy, periodic limited by T_{jmax}	E_{AR}	12	
Reverse diode dv/dt $I_S = 47$ A, $V_{DS} = 40$ V, $dI/dt = 200$ A/ μ s, $T_{jmax} = 175$ °C	dv/dt	6	kV/ μ s
Gate source voltage	V_{GS}	-20	V
Power dissipation $T_C = 25$ °C	P_{tot}	120	W
Operating and storage temperature	T_j, T_{stg}	-55... +175	°C
IEC climatic category; DIN IEC 68-1		55/175/56	

■ 8235605 0133392 506 ■

Thermal Characteristics

Parameter	Symbol	Values			Unit
		min.	typ.	max.	
Characteristics					
Thermal resistance, junction - case	R_{thJC}	-	-	1.25	KW
Thermal resistance, junction - ambient, leded	R_{thJA}	-	-	62	
SMD version, device on PCB: @ min. footprint @ 6 cm ² cooling area ¹⁾	R_{thJA}	-	-	62 40	

Electrical Characteristics, at $T_j = 25\text{ }^\circ\text{C}$, unless otherwise specified

Parameter	Symbol	Values			Unit
		min.	typ.	max.	
Static Characteristics					
Drain- source breakdown voltage $V_{GS} = 0\text{ V}$, $I_D = 0.25\text{ mA}$	$V_{(BR)DSS}$	55	-	-	V
Gate threshold voltage, $V_{GS} = V_{DS}$ $I_D = 90\text{ }\mu\text{A}$	$V_{GS(th)}$	1.2	1.6	2	
Zero gate voltage drain current $V_{DS} = 50\text{ V}$, $V_{GS} = 0\text{ V}$, $T_j = 25\text{ }^\circ\text{C}$ $V_{DS} = 50\text{ V}$, $V_{GS} = 0\text{ V}$, $T_j = 150\text{ }^\circ\text{C}$	I_{DSS}	-	0.1	1 100	μA
Gate-source leakage current $V_{GS} = 20\text{ V}$, $V_{DS} = 0\text{ V}$	I_{GSS}	-	10	100	
Drain-Source on-state resistance $V_{GS} = 4.5\text{ V}$, $I_D = 33\text{ A}$ $V_{GS} = 10\text{ V}$, $I_D = 33\text{ A}$	$R_{DS(on)}$	-	0.021 0.0135	0.024 0.015	Ω

¹ Device on 40mm*40mm*1.5mm epoxy PCB FR4 with 6 cm² (one layer, 70 μm thick) copper area for drain connection. PCB is vertical without blown air.

■ 8235605 0133393 442 ■

Electrical Characteristics, at $T_j = 25\text{ }^\circ\text{C}$, unless otherwise specified

Parameter	Symbol	Values			Unit
		min.	typ.	max.	
Dynamic Characteristics					
Transconductance $V_{DS} \geq 2 \cdot I_D \cdot R_{DS(on)max}$, $I_D = 33\text{ A}$	g_{fs}	10	40	-	S
Input capacitance $V_{GS} = 0\text{ V}$, $V_{DS} = 25\text{ V}$, $f = 1\text{ MHz}$	C_{iss}	-	1380	1730	pF
Output capacitance $V_{GS} = 0\text{ V}$, $V_{DS} = 25\text{ V}$, $f = 1\text{ MHz}$	C_{oss}	-	410	515	
Reverse transfer capacitance $V_{GS} = 0\text{ V}$, $V_{DS} = 25\text{ V}$, $f = 1\text{ MHz}$	C_{rss}	-	230	290	
Turn-on delay time $V_{DD} = 30\text{ V}$, $V_{GS} = 4.5\text{ V}$, $I_D = 47\text{ A}$, $R_G = 3.6\text{ }\Omega$	$t_{d(on)}$	-	15	25	ns
Rise time $V_{DD} = 30\text{ V}$, $V_{GS} = 4.5\text{ V}$, $I_D = 47\text{ A}$, $R_G = 3.6\text{ }\Omega$	t_r	-	30	45	
Turn-off delay time $V_{DD} = 30\text{ V}$, $V_{GS} = 4.5\text{ V}$, $I_D = 47\text{ A}$, $R_G = 3.6\text{ }\Omega$	$t_{d(off)}$	-	30	45	
Fall time $V_{DD} = 30\text{ V}$, $V_{GS} = 4.5\text{ V}$, $I_D = 47\text{ A}$, $R_G = 3.6\text{ }\Omega$	t_f	-	20	30	

■ 8235605 0133394 389 ■

Electrical Characteristics, at $T_j = 25\text{ }^\circ\text{C}$, unless otherwise specified

Parameter	Symbol	Values			Unit
		min.	typ.	max.	
Dynamic Characteristics					
Gate to source charge $V_{DD} = 40\text{ V}$, $I_D = 47\text{ A}$	Q_{gs}	-	7	10.5	nC
Gate to drain charge $V_{DD} = 40\text{ V}$, $I_D = 47\text{ A}$	Q_{gd}	-	23	34.5	
Gate charge total $V_{DD} = 40\text{ V}$, $I_D = 47\text{ A}$, $V_{GS} = 0\text{ to }10\text{ V}$	Q_g	-	60	90	
Gate plateau voltage $V_{DD} = 40\text{ V}$, $I_D = 47\text{ A}$	$V_{(\text{plateau})}$	-	4.1	-	V

Reverse Diode

Inverse diode continuous forward current $T_C = 25\text{ }^\circ\text{C}$	I_S	-	-	47	A
Inverse diode direct current, pulsed $T_C = 25\text{ }^\circ\text{C}$	I_{SM}	-	-	188	
Inverse diode forward voltage $V_{GS} = 0\text{ V}$, $I_F = 94\text{ A}$	V_{SD}	-	1.1	1.7	V
Reverse recovery time $V_R = 30\text{ V}$, $I_F = I_S$, $di_F/dt = 100\text{ A}/\mu\text{s}$	t_{rr}	-	75	115	ns
Reverse recovery charge $V_R = 30\text{ V}$, $I_F = I_S$, $di_F/dt = 100\text{ A}/\mu\text{s}$	Q_{rr}	-	0.15	0.25	μC

■ 8235605 0133395 215 ■

Power Dissipation

$P_{tot} = f(T_C)$

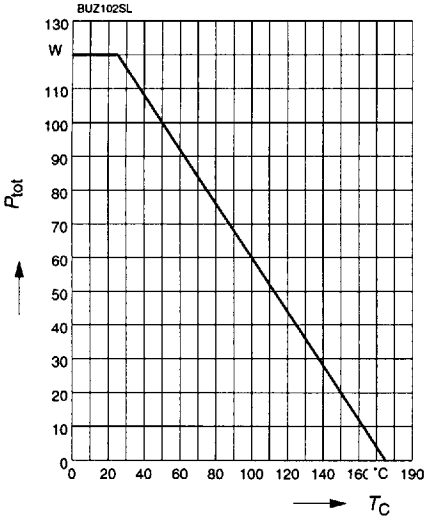

Drain current

$I_D = f(T_C)$

parameter: $V_{GS} \geq 10$ V

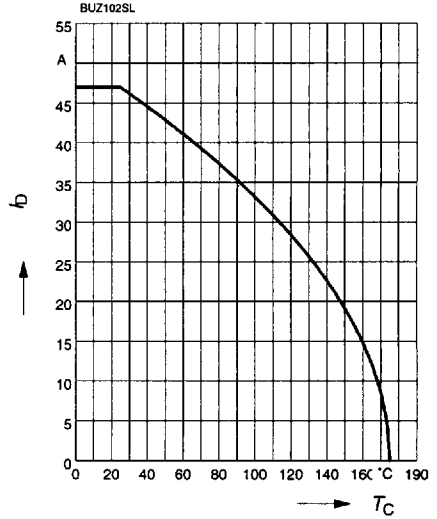

Safe operating area

$I_D = f(V_{DS})$

parameter: $D = 0$, $T_C = 25$ °C

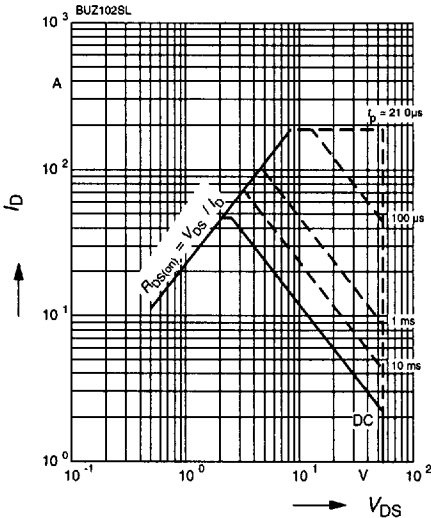

Transient thermal impedance

$Z_{thJC} = f(t_p)$

parameter: $D = t_p/T$

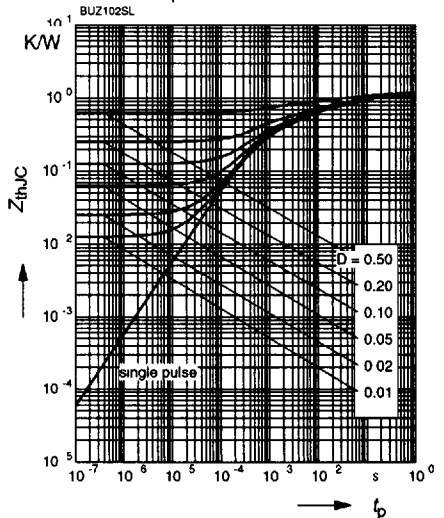

Typ. output characteristics

$I_D = f(V_{DS})$

parameter: $t_p = 80 \mu s$

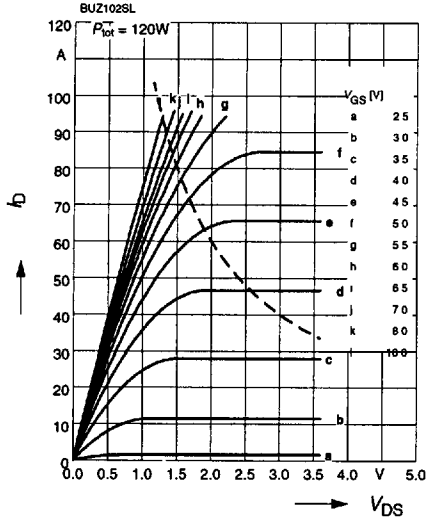

Typ. drain-source-on-resistance

$R_{DS(on)} = f(I_D)$

parameter: V_{GS}

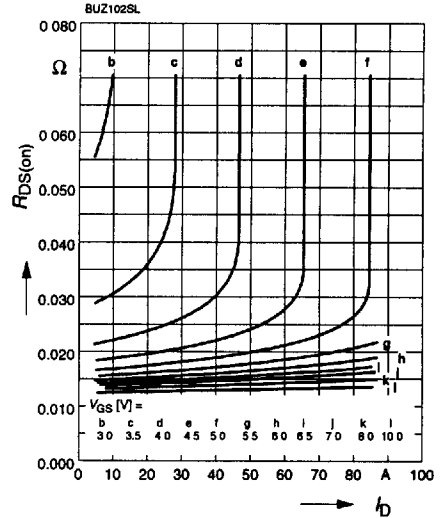

Typ. transfer characteristics $I_D = f(V_{GS})$

parameter: $t_p = 80 \mu s$

$V_{DS} \geq 2 \times I_D \times R_{DS(on)max}$

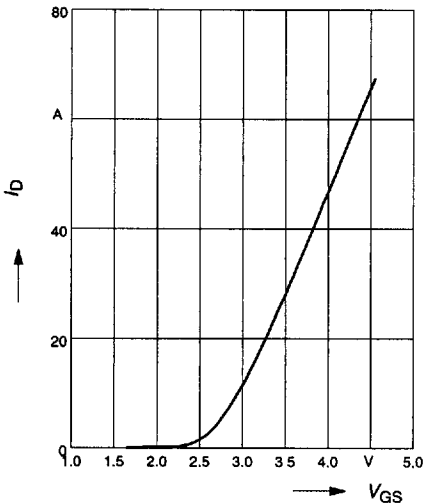

Typ. forward transconductance

$g_{fs} = f(I_D); T_j = 25^\circ C$

parameter: g_{fs}

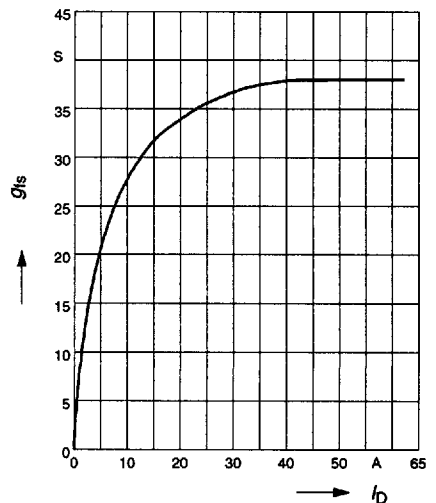

Drain-source on-resistance

$$R_{DS(on)} = f(T_j)$$

parameter : $I_D = 33 \text{ A}$, $V_{GS} = 4.5 \text{ V}$

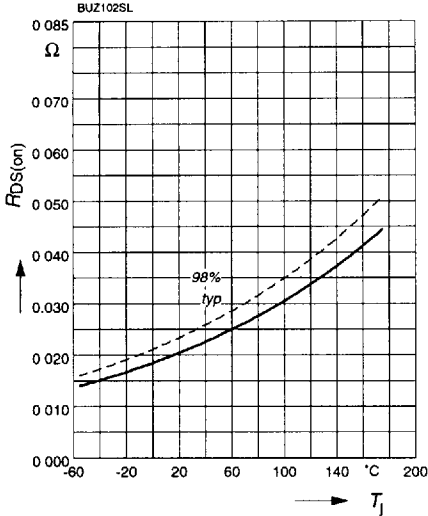

Gate threshold voltage

$$V_{GS(th)} = f(T_j)$$

parameter : $V_{GS} = V_{DS}$, $I_D = 90 \mu\text{A}$

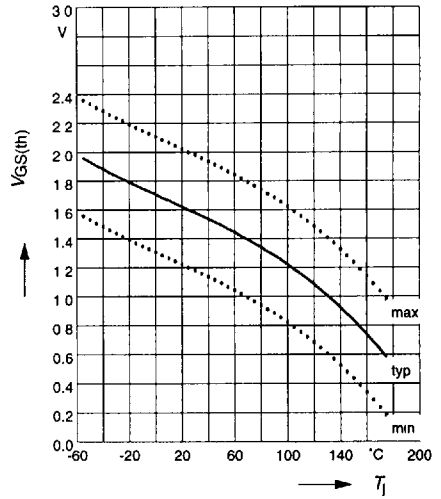

Typ. capacitances

$$C = f(V_{DS})$$

parameter: $V_{GS} = 0 \text{ V}$, $f = 1 \text{ MHz}$

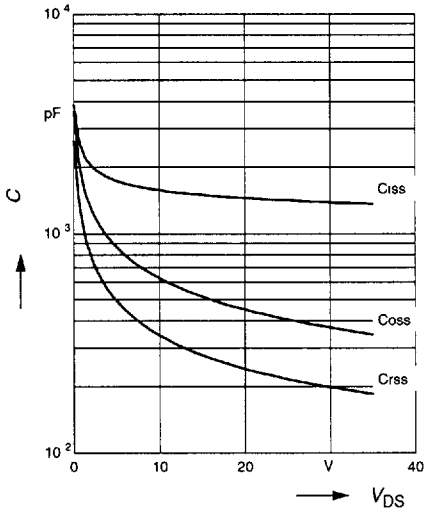

Forward characteristics of reverse diode

$$I_F = f(V_{SD})$$

parameter: T_j , $t_p = 80 \mu\text{s}$

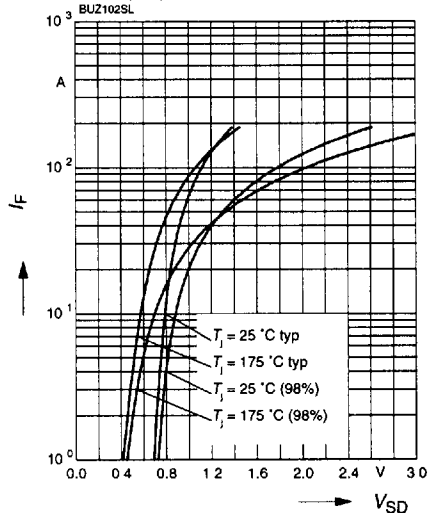

8235605 0133398 T24

Avalanche Energy $E_{AS} = f(T_j)$

parameter: $I_D = 47\text{ A}$, $V_{DD} = 25\text{ V}$

$R_{GS} = 25\ \Omega$

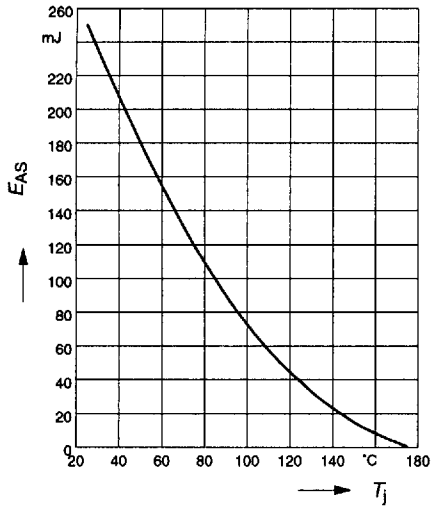

Typ. gate charge

$V_{GS} = f(Q_{Gate})$

parameter: $I_{D\text{ puls}} = 47\text{ A}$

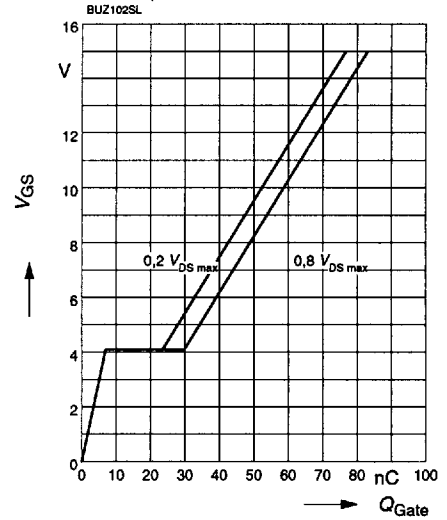

Drain-source breakdown voltage

$V_{(BR)DSS} = f(T_j)$

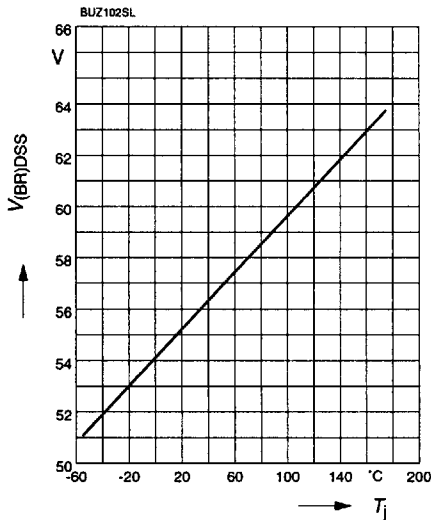

Gehäusemaßbilder

(Maße in mm, wenn nicht anders angegeben)

Package Outlines

(Dimensions in mm, unless otherwise specified)



Bild 16

Figure 16

P-TO218-AA (P-TO218-2-1)

Gewicht etwa 4.9 g
Approx. weight 4.9 g

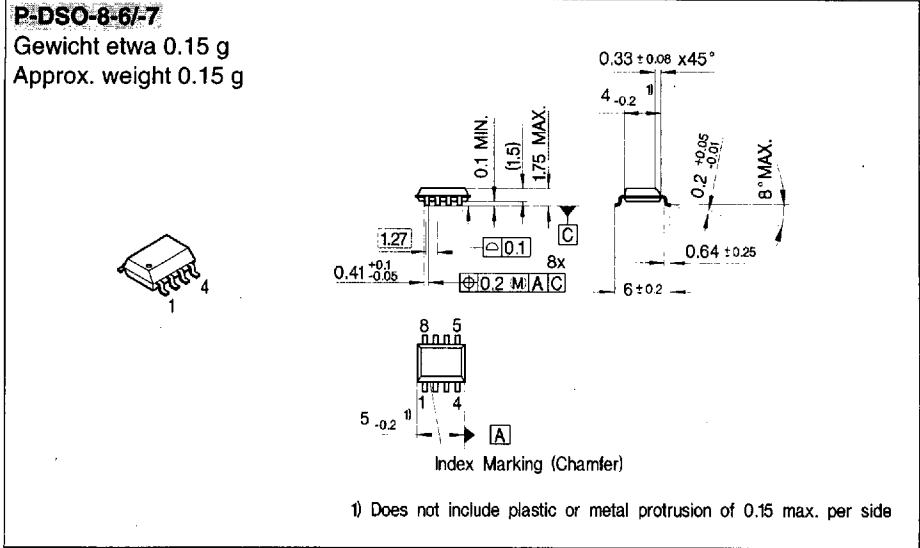
Bild 17

Figure 17



Bild 18

Figure 18

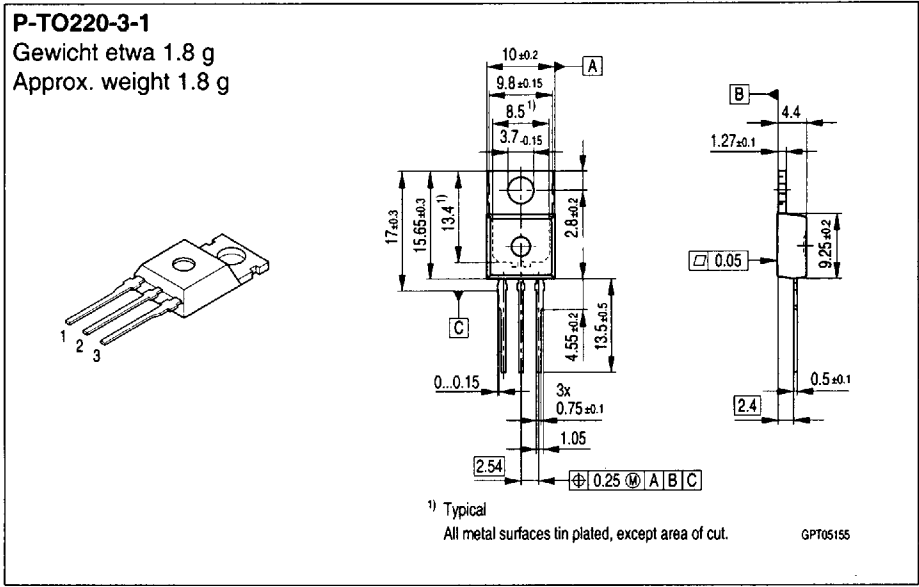

Bild 19

Figure 19

P-TO252-3-1

Gewicht etwa 0.38 g
Approx. weight 0.38 g

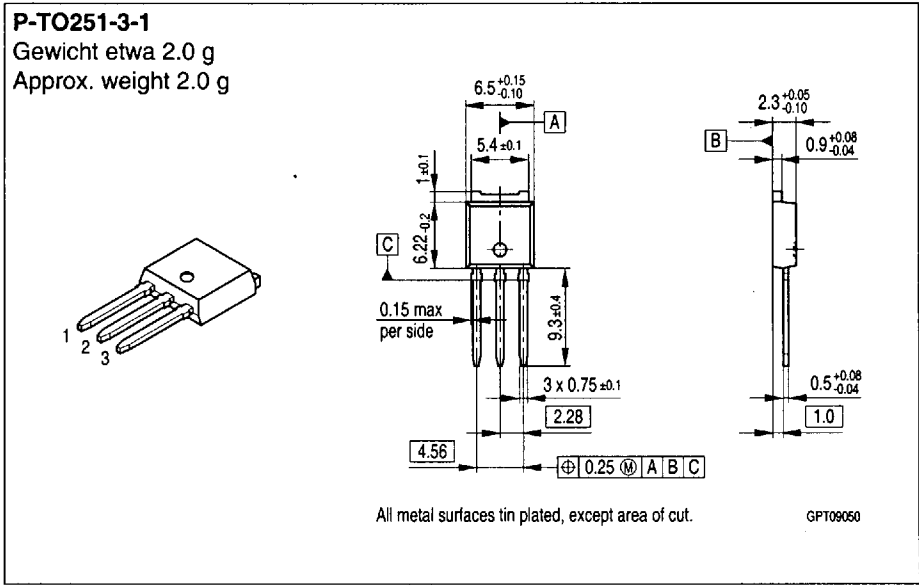
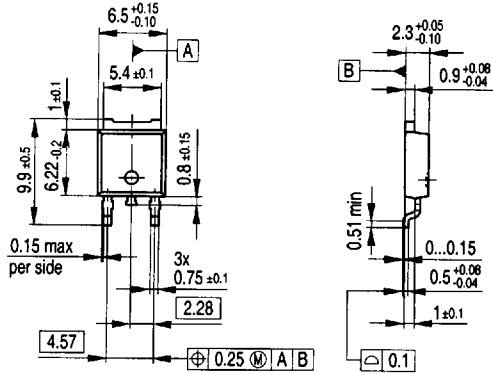
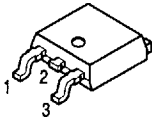

All metal surfaces tin plated, except area of cut.

GPT09051

Bild 20

Figure 20

P-TO262-3-1/l²PAK

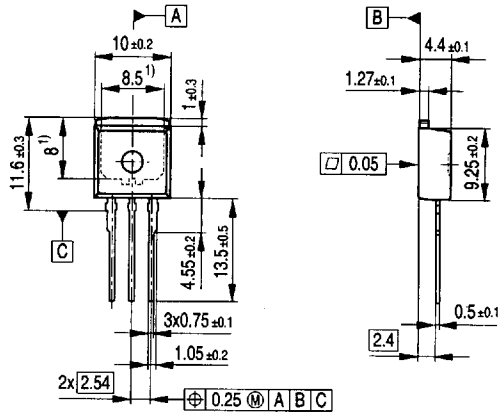
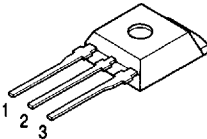

1) Typical

Metal surface min. X = 7.25, Y = 7.35

All metal surfaces tin plated, except area of cut.

GPT09244

Bild 21

Figure 21

P-TO263-3-2/D²PAK

Gewicht etwa 1.38 g
Approx. weight 1.38 g

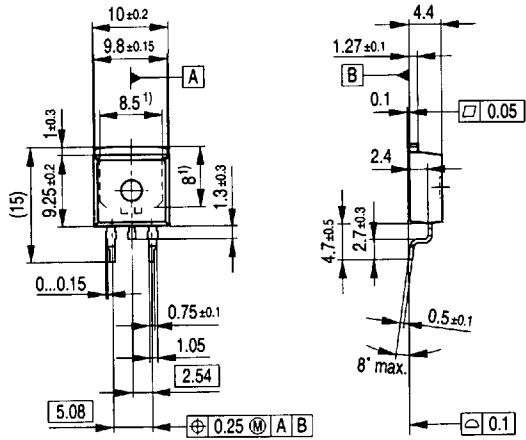
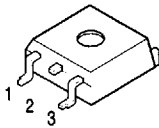

¹⁾ Typical

All metal surfaces tin plated, except area of cut.

GPT09085

Bild 22

Figure 22

SOT-23 (P-SOT23-3-1)

Gewicht etwa 0.01 g
Approx. weight 0.01 g

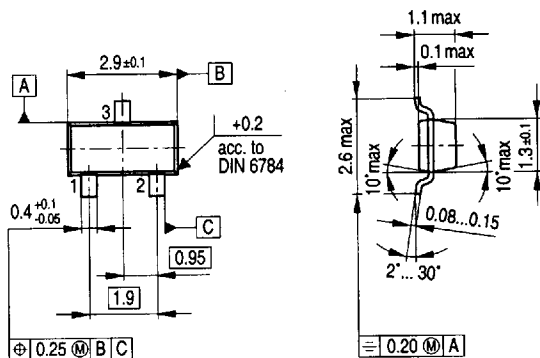
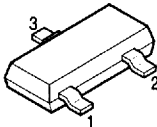

GPS05557

Bild 23

Figure 23

SOT-89

Gewicht etwa 0.01 g
Approx. weight 0.01 g



Bild 24

Figure 24

SOT-223 (P-SOT223-4-1)

Gewicht etwa 0.15 g
Approx. weight 0.15 g

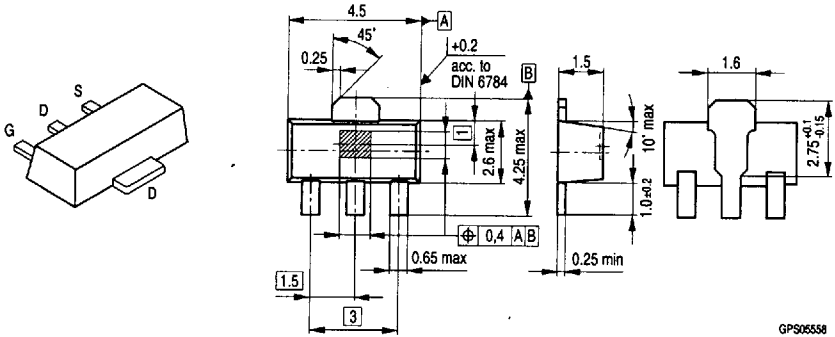

Bild 25

Figure 25

TO-92

Gewicht etwa 0.23 g
Approx. weight 0.23 g

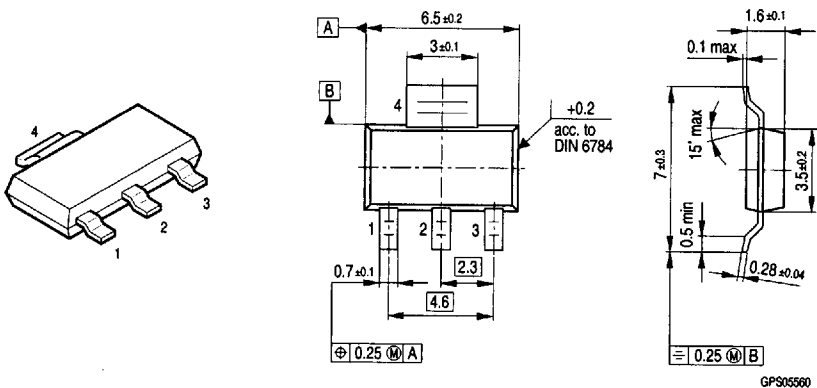

Bild 26

Figure 26

TO-92-E6288

Gewicht etwa 0.23 g
Approx. weight 0.23 g

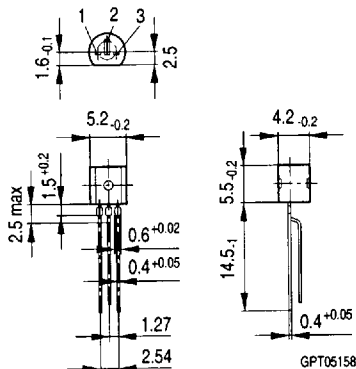
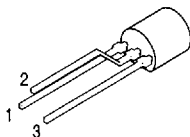

Bild 27

Figure 27

Sorts of Packing

Package outlines for tubes, trays etc. are contained in our Data Book "Package Information".

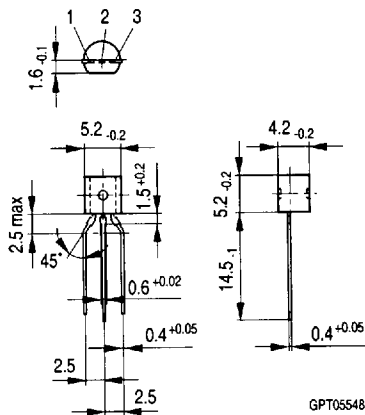
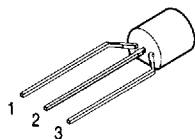
SMD = Surface Mounted Device