

RoHS

REV	ECN NO.	DESCRIPTION	DESIGN	APPROVAL	DATE
A1	NEW	更换图框			2023.11.25

技术要求:

1. 打铜底 $0.5-1\mu\text{m}$, 镍 $2-2.5\mu\text{m}$, 哑锡 $3-5\mu\text{m}$ 。
2. 不得有变形, 毛刺等现象。
3. 插脚尖部符合可焊性要求。
4. 螺纹需符合通止规/止针要求。
5. 螺纹扭矩: 1.2Nm 。
6. 额定电流: 40A 。
7. X为重点测量尺寸。

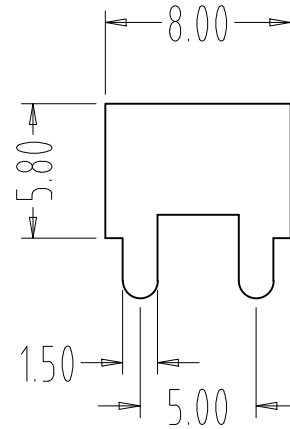
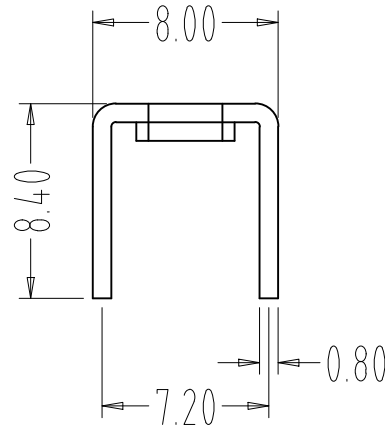
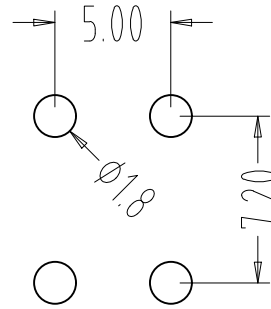
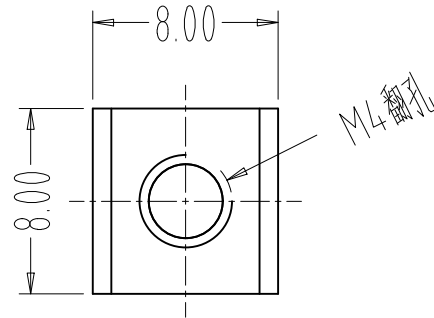

>30 ±0.40	x.°±
6-30 ±0.30	.x°±
0-6 ±0.20	.xx°±
ANGLES ±1°	.xxx°±
UNITS:	mm

PART NO: T44001	
TITLE: PCB SOLDERING TERMINAL	
APPD	
CHKD	
DRAW	Wang
DATE	2023.11.25

XFCN 兴飞连接器	
0769-82001899	
www.xfconn.com	
DWG NO: /	

THESE DRAWINGS AND SPECIFICATIONS ARE THE PROPERTY OF XFCN AND SHALL NOT BE REPRODUCED, COPIED OR CUED IN ANY MANNER WITHOUT THE PRIOR WRITTEN CONSENT OF XFCN

1	插脚		H62(Y2)	1
序号	名称	零件编号	材质	数量

VIEW			
SCALE	SHEET	REV	
NONE	1:1	A1	