

4

3

2

1

D

D

C

C

B

B

A

A

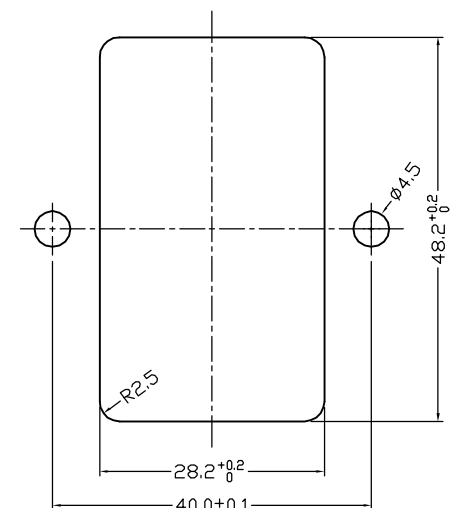
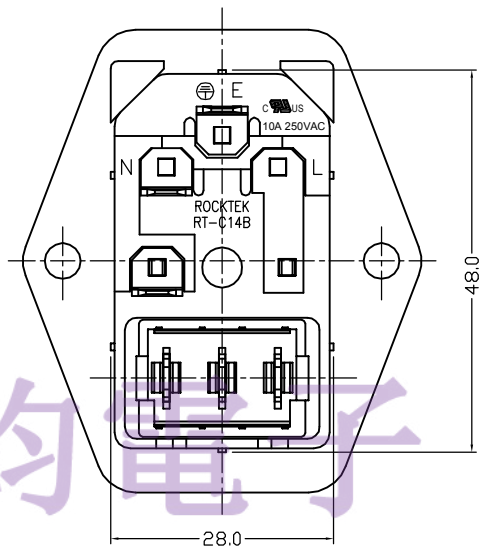
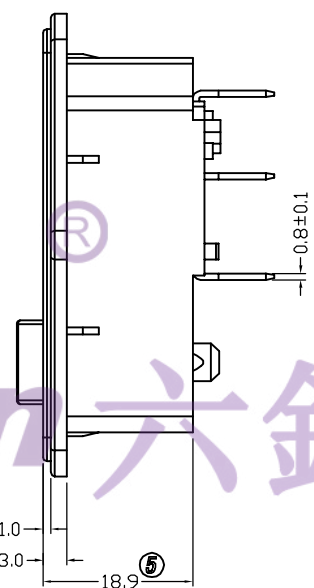
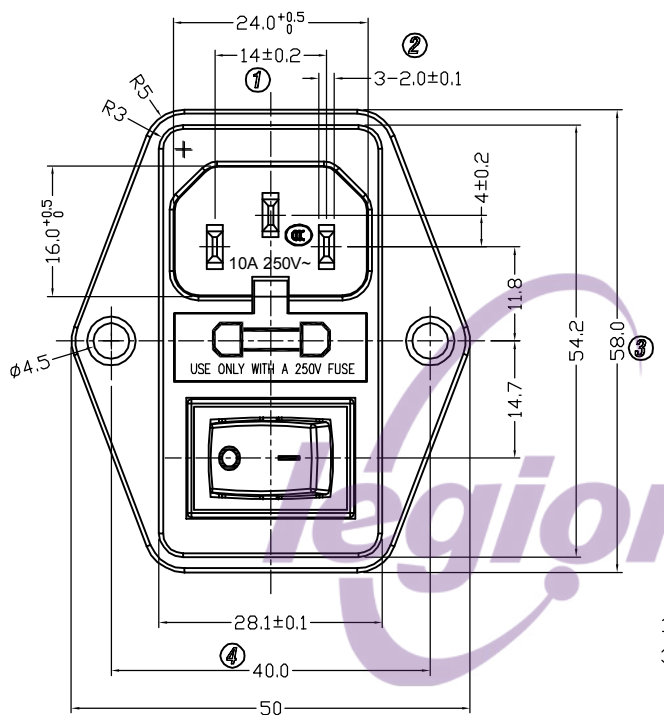

PANEL CUT-OUT

TEL: 0769-82310511-867

Socket : RT-C14B-H00-13-R

- 1.Rating : 10A 250VAC (CCC ; UL ; CUL)
- 2.Insulation resistance : >100MΩ Min 500VDC
- 3.Withstand voltage : >2000VAC 0.5mA 1 minute

Switch : RT-S01-113-L4LBR

- 1.Rating : 10A 125VAC 6A 250VAC (UL ; CUL ; CQC)
10(4)A 250V~ (VDE)
- 2.Contact resistance : <50mΩ
- 3.Insulation resistance : >100MΩ Min 500VDC
- 4.Dielectric strength : >1500VAC 0.5mA 1 minute

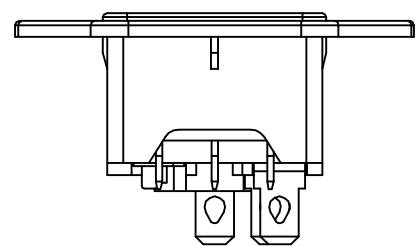

5	→	10	→	DIMENSIONAL TOLERANCES		APPROVED	CHECKED	DESIGN	DRAWN	ALL SIZE ARE IN	MM			
4	→	9	→	RANGE	TOLERANCE				LMC	SCALE	NO			
3	→	8	→	X	±0.15				2019.09.12	MAT'L	***	DRAWING NO.	REV.	
2	→	7	→	X.X	±0.10					MATERIAL NO.				
1	→	6	→	X.XX	±0.05							RT-C14B-H1+RT-S01-2BR	WIF119144	AO
NO	DESCRIPTION	NO	DESCRIPTION	ANGLES	±1'	LECION ELECTRONIC & HARDWARE CO., LTD.								

4

3

2

1