

**G-Switch USB-C Specification:**

1. Current rated: 5A on vbus/1.25A on vconn/0.25A on other
2. Voltage rating: 24V AC
3. Withstanding voltage: 100V AC/minute
4. Contact resistance: 40mΩ Max
5. Insulation resistance: 100MΩ Min
6. Operating temperature: -40°C ~ +85°C
7. Mating force: 5N~20N
8. Unmating force: 8N~20N
9. Durability cycle: 10,000 cycles
10. Data transmission rate up to 5Gbps

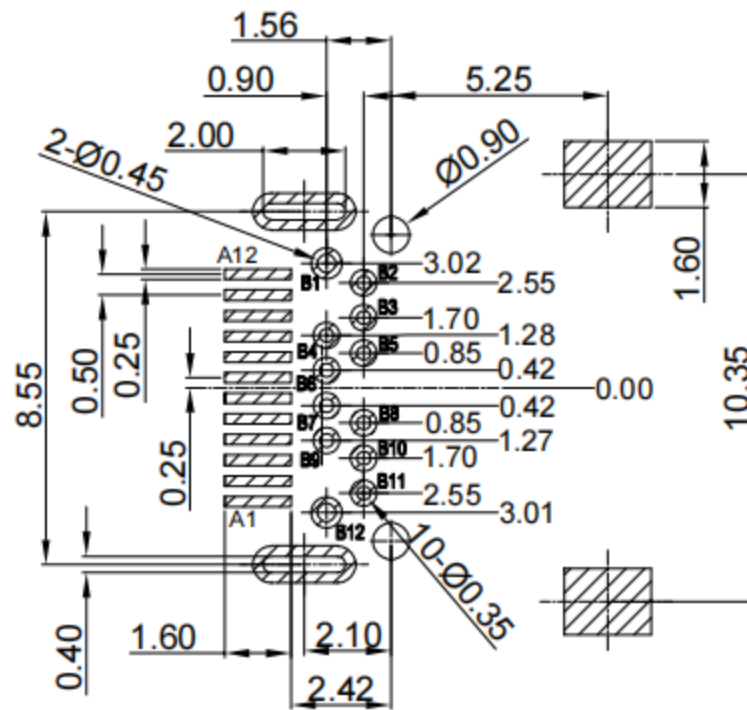
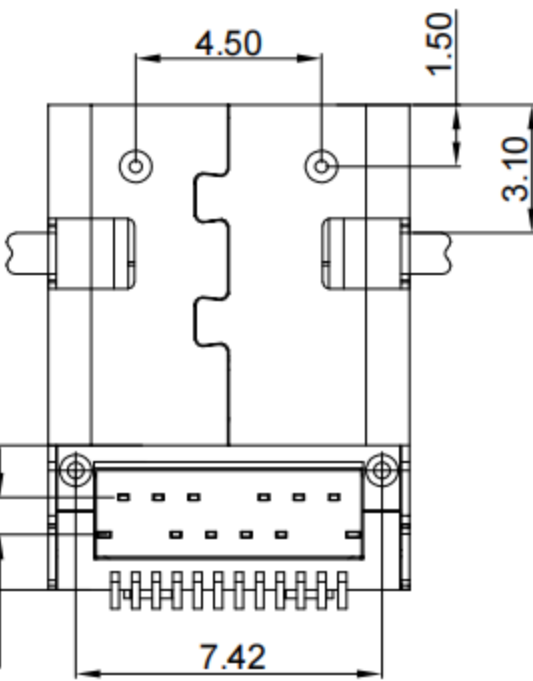

A1	A2	A3	A4	A5	A6	A7	A8	A9	A10	A11	A12
GND	TX1+	TX1-	VBUS	CC1	D+	D-	SBU1	VBUS	RX2-	RX2+	GND
First	Second	Second	First	Second	Second	Second	Second	First	Second	Second	First
B12	B11	B10	B9	B8	B7	B6	B5	B4	B3	B2	B1
GND	RX1+	RX1-	VBUS	SBU2	D-	D+	CC2	VBUS	TX2-	TX2+	GND
First	Second	Second	First	Second	Second	Second	Second	First	Second	Second	First

RECOMMENDED PCB LAYOUT  
TOLERANCE: ±0.05

	SHELL	STAINLESS STEEL	NI PLATED
2	INNER GROUND COVER SHELL	STAINLESS STEEL	---
3	MID PLATE	STAINLESS STEEL	NI PLATED
4	HOUSING	HIGH TEMPERATURE PLASTIC	Black UL 94 V-0
5	TERMINALS	COPPER ALLOY	Au PLATING ON CONTACT AREA
NO.	PARTS	MATERIAL	REMARKS



SCALE: 1:1 UNIT: mm  
SIZE: A4

Unless otherwise  
General Tolerance:  
X. ±0.25  
X.x ±0.20  
X.xx ±0.15  
X.xxx ±0.10  
X\* ±5°

Title: Horizontal Type-c 24P Female  
SMT CH=1.7 L=11.95mm

Molde Code: GT-USB-7017A

DRAWN	CHECKED	APPROVED	DATE
Xia	Chen	Chen	2023.02.01



REV: A0 SHEET: 1/1