

REV.	Q'TY	ECN. NO.	APR.	DATE

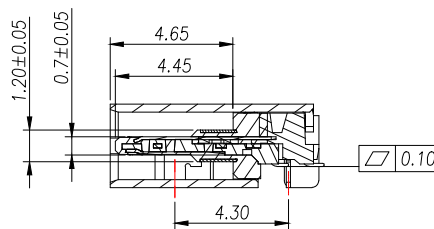
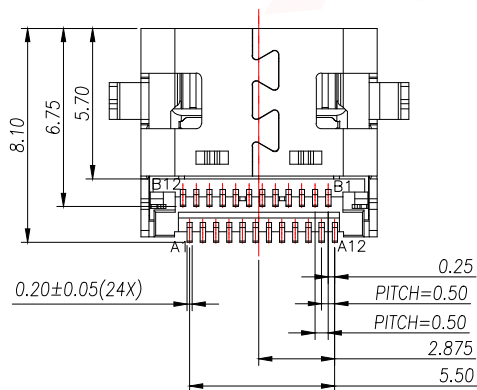
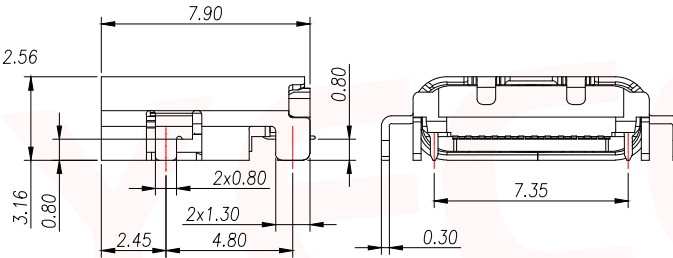
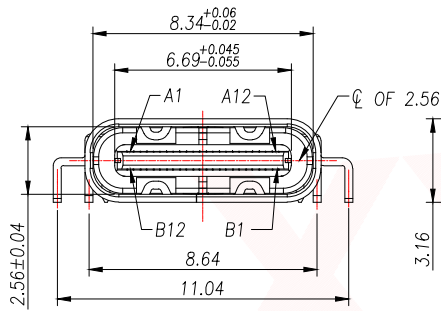
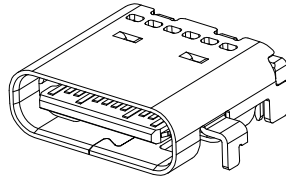
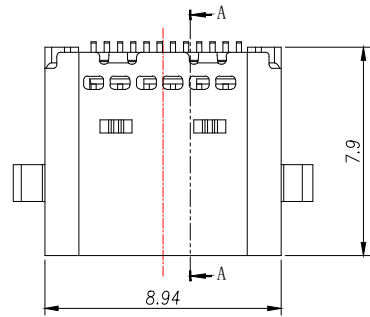

NOTE:

1.MATERIAL SPECIFICATION:

- 1.HOUSING:PA9T,BLACK,UL94 V-0.
- 2.TERMINAL:COPPER ALLOY (C1814)
- 3.MID PLATE: STAINLESS STEEL (SUS301)
- 4.FRONT SHELL: STAINLESS STEEL (SUS304)
- 5.TOP SHELL: STAINLESS STEEL (SUS304)

2.PLATING SPECIFICATION:

2-1.CONTACTS:

- Ni 50u" MIN. UNDER PLATED OVER ALL.
- GOLD-FLASH PLATED ON THE FUNCTIONAL AREA OF CONTACT.
- GOLD-FLASH PLATED ON THE SOLDER

2-2.FRONT SHELL&TOP SHELL:

- Ni 30u" MIN. UNDER PLATED OVER ALL.

2-3.MID PLATE:

- CLEAR ONLY

3.MECHANICAL PERFORMANCE.

- 3-1.INSERTION FORCE: 0.5~2.0kgf.
- 3-2.REMOVAL FORCE: 0.8kgf~2.0kgf.
- 3-3.DURABILITY: 10000 CYCLES.

4.ELECTRICAL PERFORMANCE.

- 4-1. VOLTAGE RATING:5 V DC/AC (RMS. max)
- CURRENT RATING:5 AMPS. FOR TOTAL VBUS/GND PINS;
- 1.25AMPS FOR CC PIN,0.25 AMPS. FOR ALL OTHER CONTACT.

4-2. LLCR:

- VBUS & GND PINS AND OTHER PINS: 40mΩ/PIN MAX.
- SHIELD: 50mΩ/MAX.
- LLCR MAX. CHANGE OF ALL PINS: 10mΩ.

4-3.INSULATION RESISTANCE: 100MΩ MIN

4-4.DIELECTRIC WITHSTAND VOLTAGE,AC 100V FOR 1 MINUTE.

5. ENVIRONMENTAL PERFORMANCE:

- OPERATING TEMPERATURE: -40°C~+85°C.

6.IR REFLOW:

- THE PEAK TEMPERATURE ON THE BOARD SHALL BE MAINTAINED FOR 10 SECONDS AT 260°C.

DIMENSION IN mm		厦门市辛译精密电子有限公司 Xiamen XinYi Xyconn Electronics Co.,Ltd	
TOLERANCE UNLESS OTHERWISE SPECIFIED		APR.	Alex
.X±0.35	X.*± 5°	CHK.	Jack
.XX±0.25	.X.*± 3°	DRA.	Can
.XXX±0.15	.XX.*± 1°	TITLE: USB TYPE C/F 24PIN SMT MID-MOUNT 0.8	
		DWG NO. TYPE-C-G06-1BBWC0.8	
		PROJ. CUSTOMER DRAWING	
SIZE A4	SCALE 1:1	SHEET 1/3	REV. A

REV.	Q'TY	ECN. NO.	APR.	DATE

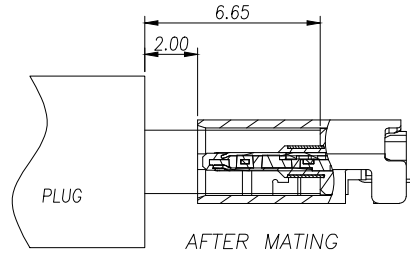

USB TYPE-C PIN ASSIGNMENTS

PIN NUMBER	SIGNAL NAME	PIN NUMBER	SIGNAL NAME
A1	GND	B12	GND
A2	TXp1	B11	RXp1
A3	TXn1	B10	RXn1
A4	VBUS	B9	VBUS
A5	CC1	B8	SBU2
A6	Dp1	B7	Dn2
A7	Dn1	B6	Dp2
A8	SBU1	B5	CC2
A9	VBUS	B4	VBUS
A10	RXn2	B3	TXn2
A11	RXp2	B2	TXp2
A12	GND	B1	GND

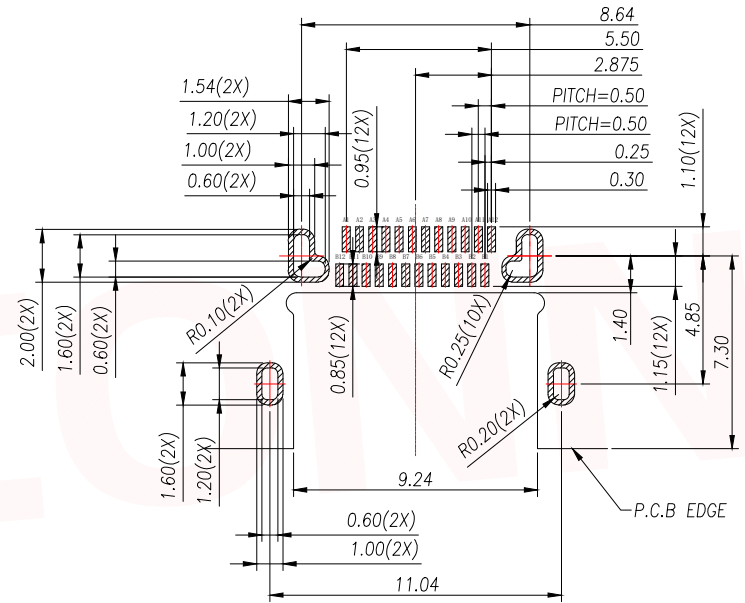

RECOMMENDED PCB LAYOUT(TOP VIEW)
THICKNESS 0.60MM;DEFAULT TOLERANCE:±0.05

DIMENSION IN mm		厦门市辛译精密电子有限公司 Xiamen XinYi Xyeconn Electronics Co.,Ltd		
TOLERANCE UNLESS OTHERWISE SPECIFIED				
.X±0.35	X.*± 5°	APR. Alex	TITLE: USB TYPE C/F 24PIN SMT MID-MOUNT 0.8	
.XX±0.25	.X.*± 3°	CHK. Jack	DWG NO. TYPE-C-G06-1BBWC0.8	
.XXX±0.15	.XX.*± 1°	DRA. Can	PROJ.	CUSTOMER DRAWING
SIZE A4	SCALE 1:1	SHEET 2/3	REV. A	

REV.	Q'TY	ECN. NO.	APR.	DATE

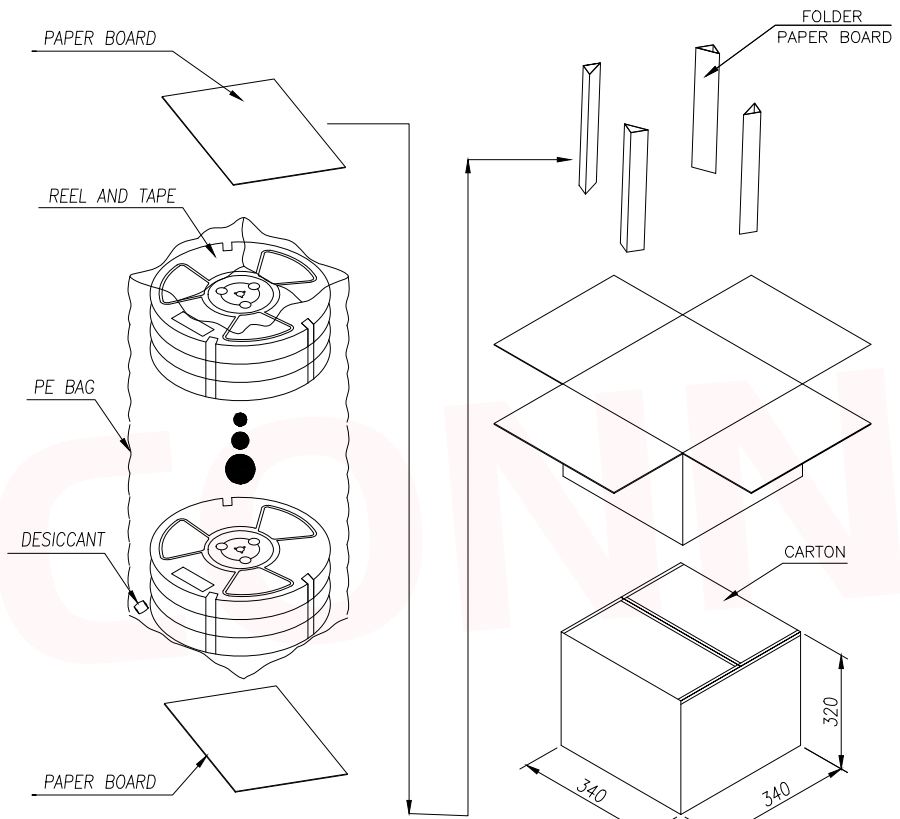
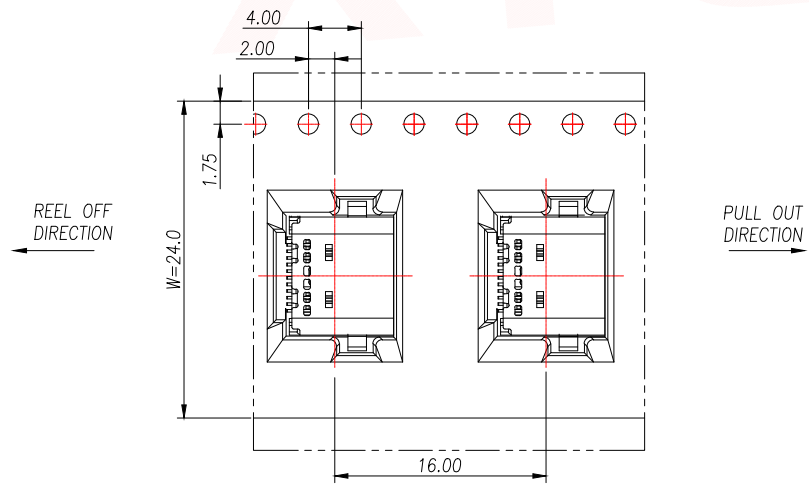
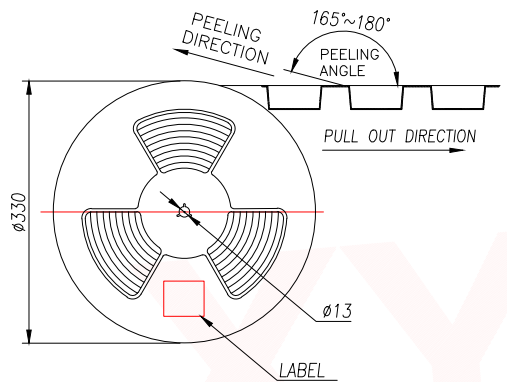
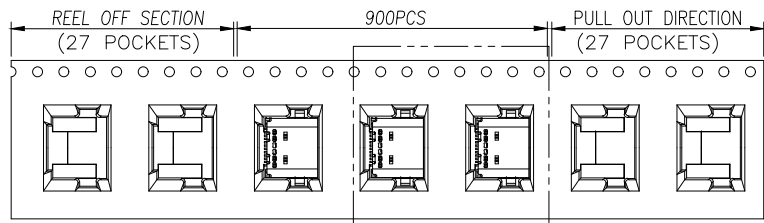

	REEL	CARTON
CONNECTOR (PCS)	900	9000

DIMENSION IN mm		厦门市辛译精密电子有限公司 Xiamen XinYi Xyconn Electronics Co.,Ltd		
TOLERANCE UNLESS OTHERWISE SPECIFIED				
.X \pm 0.35	X.* \pm 5'	APR. Alex	TITLE: USB TYPE C/F 24PIN SMT MID-MOUNT 0.8	
.XX \pm 0.25	.X.* \pm 3'	CHK. Jack	DWG NO. TYPE-C-G06-1BBWC0.8	
.XXX \pm 0.15	.XX.* \pm 1'	DRA. Can	PROJ.	CUSTOMER DRAWING
		SIZE A4	SCALE 1:1	SHEET 3/3
				REV. A