

- 1.CIRCUIT: ON/OFF
- 2." \varnothing "DENOTES CRITICAL DIMENSIONS.
- 3.Operation force : $800\pm 300gf$
- 4.RATING:16A GP 125/250VAC 3/4HP 125/250VAC T125(CUL)
 16(4)A 125/250V~ T125/55(ENEC17;NEMKO;CB)
 6(4)A 250~ T125/55(CQC)
 C-UL APPROVAL FILE NO.E153399
 ENEC17 CERTIFICATE NO.3689
 NEMKO CERTIFICATE NO.P10213218/A2
 CQC CERTIFICATE NO.CQC10002051908
 CB APPROVAL FILE NO.60225/A1/M1

- 5.Contact resistance : $<30m\Omega$
- 6.Insulation resistance : $>100M\Omega(500VDC$ between open contacts)
- 7.Dielectric strength : $>1500Vac$ 0.5mA 1 mintue
- 8.ACTUATOR COLOR:WHITE
 HOUSING COLOR:WHITE
 BASE COLOR:BLACK
- 9.ALL MATERIALS ARE ROHS COMPLIANT

TEL: 0769-82310511-867

PANEL CUTOUT DIMENSION:

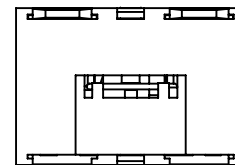
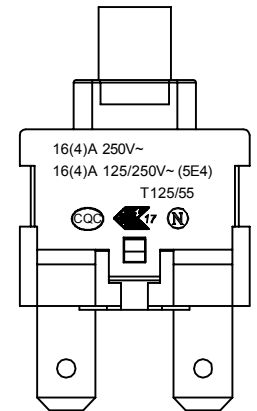
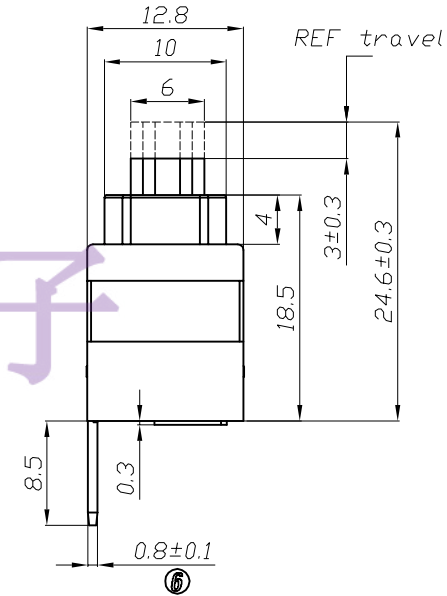
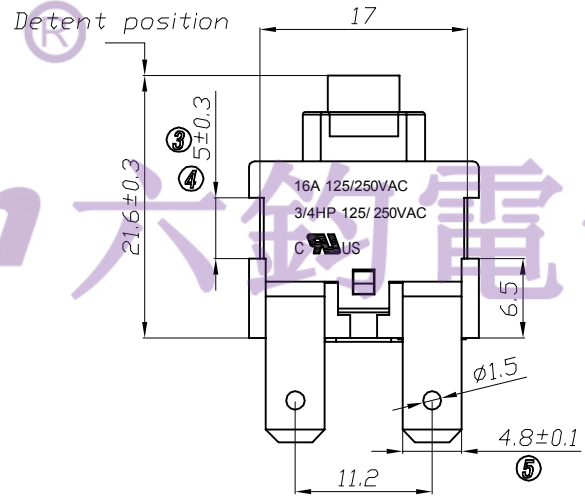
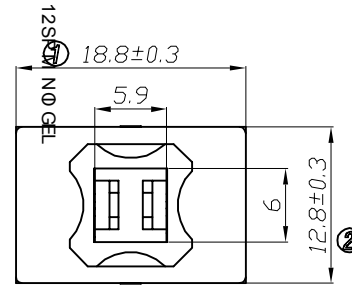
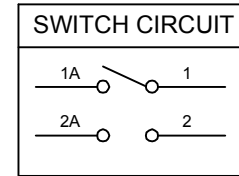
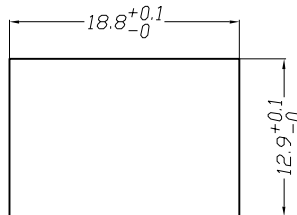

修正 REVISION	說明 DESCRIPTION	修訂者 REVISED BY	SPECIFICATION				公差 TOLERANCES		TOLERANCES UNLESS OTHERWISE SPEC.±0.5/0.02,ANG.±3		
			製圖 DRAWN BY	設計 DESIGNED BY	校對 CHECKED BY	核准 APPROVED BY	單位 UNIT	mm	機種名稱 MODEL NAME	PUSH SW	機種編號 MODEL NO.
△							比例 SCALE	5/3	六鈞電子五金有限公司 LEGION ELECTRONIC & HARDWARE CO., LTD.		
△			04-Mar-2013 唐彪	04-Mar-2013 唐彪	04-Mar-2013 唐彪	04-Mar-2013 吉慶玉	日期 DATE	2013.03.04			