

1. 电路 CIRCUIT: ON/OFF
2. 快插端子 QUICK CONNECTOR TYPE
3. 额定值 RATING: 16A 125/250VAC 3/4HP(CUL)  
16(4)A 250V~T125/55(NEMKO/ENEC17/CQC)  
10(2)A 250V~T125/55(NEMKO/ENEC17/CQC)  
20A 250V~T125/55(CQC)

4. 柄的颜色 ACTUATOR COLOR: 黑色 BLACK
5. 基座的颜色 HOUSING COLOR: 黑色 BLACK
6. 柄的印字形式 ACTUATOR PRINTING: " 1/2 "白色 WHITE COLOR
7. 所有部件均使用环保材料  
ALL MATERIALS USING MEET THE RoHS DIRECTIVE
8. "O"表示关键尺寸 DENOTES CRITICAL DIMENSIONS

TEL: 0769-82310511-867

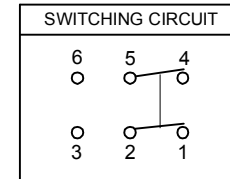
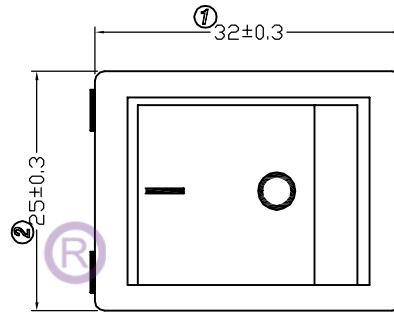

*legion* 六鈞電子

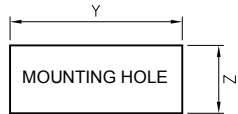

panel thickness.X	Dim.Y	Dim.Z
0.75 to 1.25mm	30.0+0/-0.1	22.0+0.1/-0
1.25 to 2mm	30.2+0.1/-0	22.0+0.1/-0
2 to 3mm	30.5+0/-0.1	22.0+0.1/-0

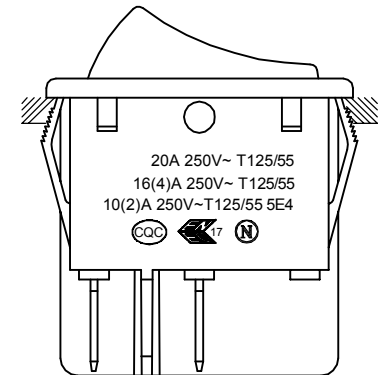
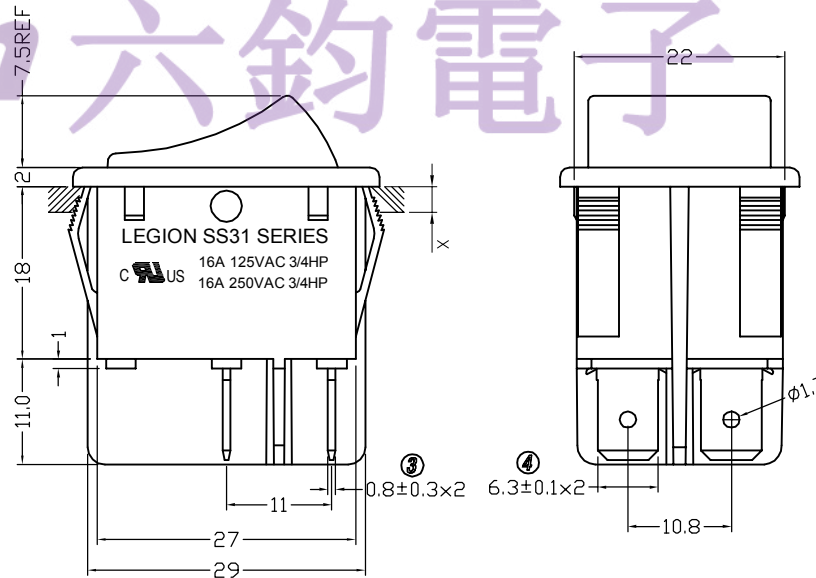

NO	DESCRIPTION	NO	DESCRIPTION	DIMENSIONAL TOLERANCES		APPROVED	CHECKED	DESIGN	DRAWN	ALL SIZE ARE IN		DRAWING NO.	REV.
				RANGE	TOLERANCE					MM	NO		
				X	±0.30				LMC				
				X.X	±0.20				2019.05.20				
				X.XX	±0.10								
				ANGLES	±1'	LEGION ELECTRONIC & HARDWARE CO., LTD.				SS31-BBIWQ-RD40-R	WIF120043	A0	