



特性:

- 国际通用全范围交流输入
- 可承受300vac浪涌输入5秒
- 空载消耗 < 0.3W
- 体积小, 1U低外型
- 工作温度可高达70°C
- 保护种类: 短路/ 过负载 / 过电压
- 自然风冷
- 符合IEC/EN 60335-1(PD3) 和IEC/EN61558-1,-2,-16 适合家电应用
- 可在海拔5000米条件下操作
- 可承受5G振动测试
- 高效率, 高寿命和高可靠度
- 电源启动LED指示灯
- 过电压等级III
- 100% 满载老化测试
- 3 年保修

电气规格

型号		LS-75-5	LS-75-12	LS-75-15	LS-75-24	LS-75-36	LS-75-48
输入	电压范围	85~264Vac 120~370Vdc(参考‘静态特性曲线’)					
	频率范围	47~63Hz					
	效率(典型值)	87%	89%	89%	90%	91.5%	91.5%
	交流电流(典型值)	1.6A/115Vac 1A/230Vac					
	浪涌电流(典型值)	65A/230Vac (冷启动)					
	漏电流	<0.75mA/240Vac					
输出	直流电压	5V	12V	15V	24V	36V	48V
	额定电流	14A	6A	5A	3.2A	2.1A	1.6A
	电流范围	0~14A	0~6A	0~5A	0~3.2A	0~2.1A	0~1.6A
	额定功率	70W	72W	75W	76.8W	75.6W	76.8W
	纹波与噪声(最大值)	100mVp-p	120mVp-p	120mVp-p	150mVp-p	200mVp-p	200mVp-p
	电压调整范围	4.5~5.5V	10.2~13.8V	13.5~18V	21.6~28.8V	32.4~39.6V	43.2~52.8V
	电压精度	±2%	±1%	±1%	±1%	±1%	±1%
	线性调整率	±0.5%	±0.5%	±0.5%	±0.5%	±0.5%	±0.5%
	负载调整率	±1%	±0.5%	±0.5%	±0.5%	±0.5%	±0.5%
	启动, 上升时间	500ms,30ms/230Vac 500ms,30ms/115Vac 满载					
	保持时间(典型值)	60ms/230Vac 12ms/115Vac 满载					
保护	过负载	110%~160% 额定输出功率 保护模式: 打嗝, 异常条件移除后自动恢复					
	过电压	5.75~6.75V	13.8~16.2V	18.8~21.8V	28.8~33.6V	41.4~48.6V	55.2~64.8V
		保护模式: 关机, 重启后恢复					
环境	工作温度	-30~+70°C (参考‘减额曲线’)					
	工作湿度	20~90% RH 无冷凝					
	储存温度、湿度	-40~+85°C, 10~95% RH 无冷凝					
	温度系数	±0.03%/°C (0~50°C)					
	耐振动	10~500Hz, 5G 10min./1 cycle, period for 60 min. each along X、Y、Z axes					
	过电压等级	III; 参考 UL61558; EN50178; EN60664-1,EN62477-1;altitude up to 2000 meters					

安规和电磁兼容	安全规范	参考 UL62368-1,TUV EN62368-1,CCC GB4943.1,IEC/EN 60335-1(PD3) and IEC/EN61558-1,-2,-16		
	耐压和绝缘阻抗	I/P-O/P: 4KVac; 100MΩ / 500Vdc / 25°C / 70%RH		
		I/P-FG: 2KVac; 100MΩ / 500Vdc / 25°C / 70%RH		
		O/P-FG: 1.25KVac; 100MΩ / 500Vdc / 25°C / 70%RH		
	电磁兼容发射	Parameter	Standard	Test Level / Note
		Conducted emission	BS EN/EN55032(CISPR32),FCC PART 15 / CISPR22 ,GB9254.1	Class B
		Radiated emission	BS EN/EN55032(CISPR32),FCC PART 15 / CISPR22 ,GB9254.1	Class B
		Harmonic current	BS EN/EN61000-3-2,GB17625.1	Class A
		Voltage flicker	BS EN/EN61000-3-3	----
	电磁兼容抗扰度	BS EN/EN55035		
		Parameter	Standard	Test Level /Note
		ESD	BS EN/EN61000-4-2	Level 4, 8KV air, Level 2, 4KV contact, criteria A
		RF field susceptibility	BS EN/EN61000-4-3	Level 3, criteria A
		EFT bursts	BS EN/EN61000-4-4	Level 3, criteria A
		Surge susceptibility	BS EN/EN61000-4-5	Level 4, 2KV/L-N, 4KV/L/N-FG criteria A
Conducted susceptibility		BS EN/EN61000-4-6	Level 3, criteria A	
Magnetic field immunity		BS EN/EN61000-4-8	Level 4, criteria A	
Voltage dips and interruptions	BS EN/EN61000-4-11	>95% dip 0.5 periods, 30% dip 25 periods , >95% interruptions 250 periods		
其他	MTBF	≥585Khrs MIL-HDBK-217F(25°C)		
	尺寸	104*82*30mm(L*W*H)		
	包装	0.23Kg; 60pcs/ 14.8Kg/ 1.03CUFT		
备注	<p>1. 如未特别说明, 所有规格参数均在输入为230VAC、额定负载、25°C 70%RH 环境温度下进行测量。</p> <p>2. 纹波和噪声测量方法: 使用一条12“双绞线, 同时终端要并联0.1uf和47uf的电容, 在20MHZ带宽下进行量测。</p> <p>3. 精度: 包含设定误差、线性调整率和负载调整率。</p> <p>4. 线性调整率测量方法: 在额定负载下, 从低电压到高电压测试。</p> <p>5. 负载调整率测量方法: 从额定负载的0%~100%。</p> <p>6. 启动时间是在冷启动状态下测得, 快速频繁开关机可能会使启动时间增长。</p> <p>7. 当工作海拔高度超过2000米(6500英尺)时, 工作环境温度必须依5°C/1000米下降。</p> <p>8. 电源应视为系统内元件的一部分, 所有的EMC测试都将测试样品安装在一个厚度1mm, 长360mm*宽360mm的金属铁板上测试。电源需结合终端设备进行电磁兼容相关确认。</p>			

机构尺寸

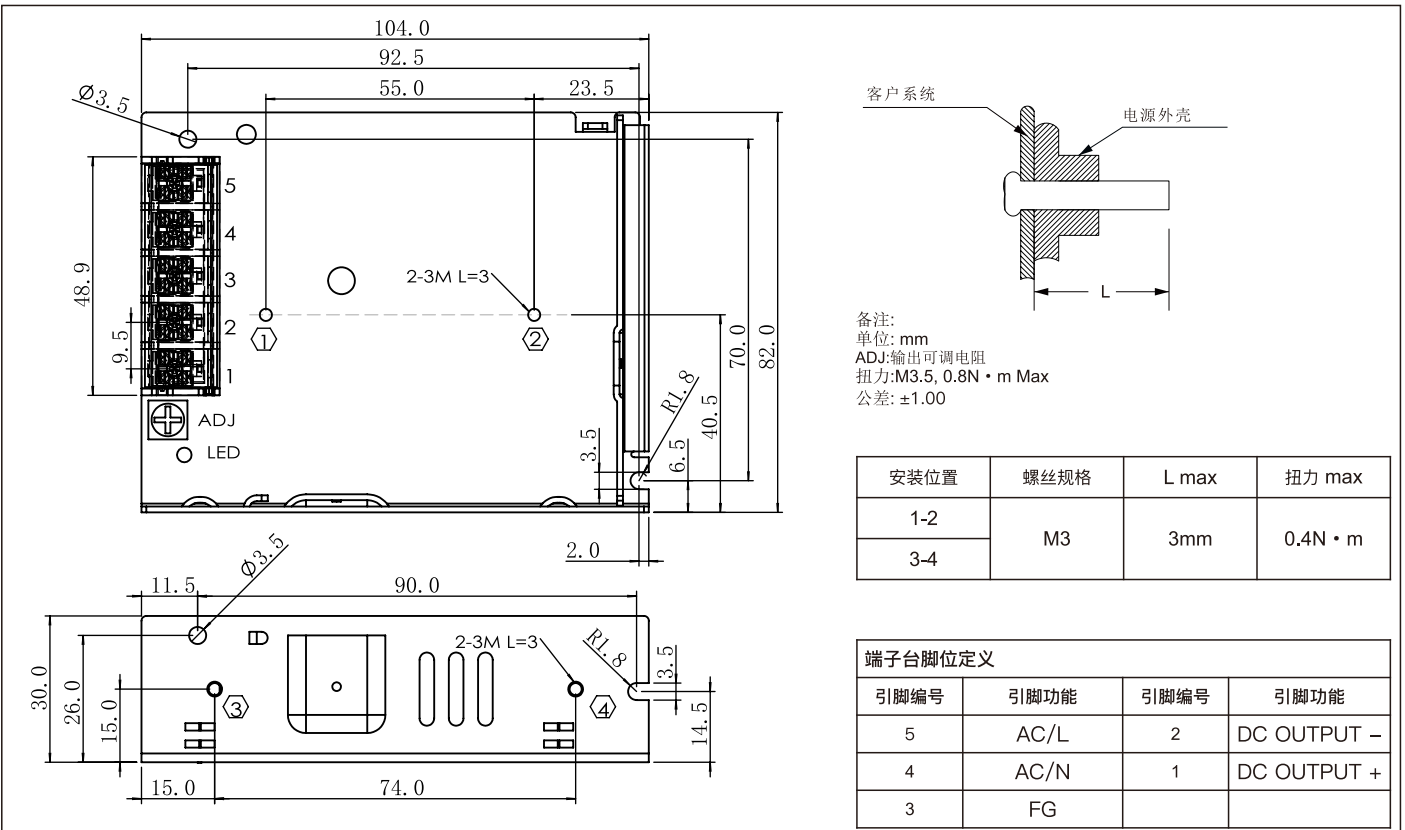

方框图

