

- 1.PUSH BUTTON SWITCH MODEL NO. MPS11-HS180-3-R
- 2.SOLDERING TYPE, SHORT TERMINAL
- 3.RATING:16A 125VAC/10A 250VAC(C-UL)
TV-5(C-UL)
5A/80A 250V~ μ T85(ENEC17;NEMKO)
12A 250VAC 5/80A 250V~ μ T125(CQC)
- 4.OPERATION FORCE:400 \pm 150gf
- 5.ALL MATERIALS USE IN CONFORMIY WITH THE RoHS DIRECTIVE

TEL: 0769-82310511-867

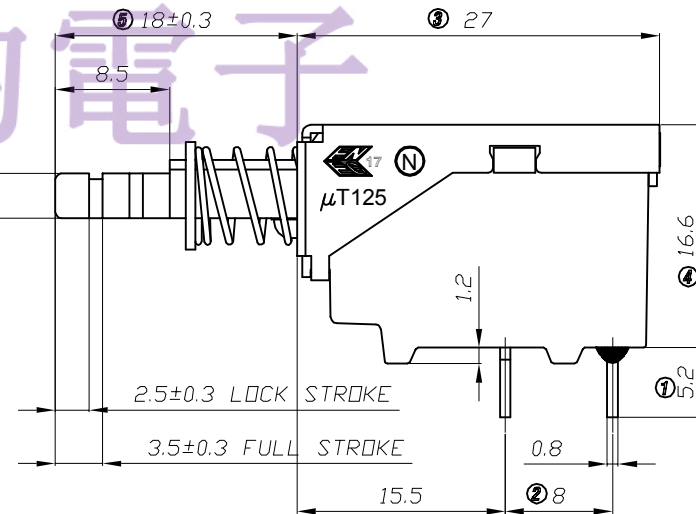
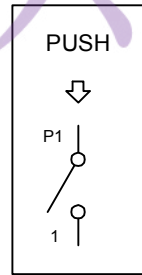
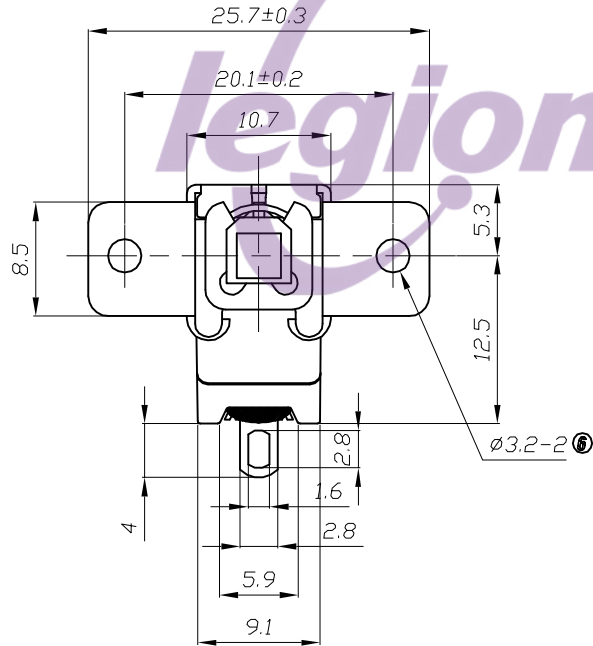
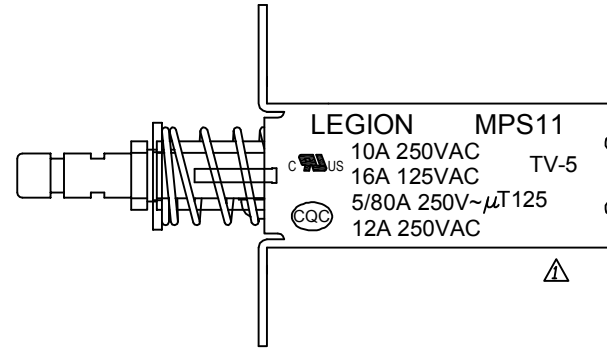

5	→	10	→	DIMENSIONAL TOLERANCES		APPROVED	CHECKED	DESIGN	DRAWN	ALL SIZE ARE IN	MM			
4	→	9	→	RANGE	TOLERANCE				LMC	SCALE	NO			
3	→	8	→	X	±0.30				2019.05.20	MAT'L	***			
2	→	7	→	X.X	±0.20					MATERIAL NO.		DRAWING NO.	REV.	
1	T85 → T125	6	→	X.XX	±0.10							MPS11-HS180-3-R	WIF119131	A1
NO	DESCRIPTION	NO	DESCRIPTION	ANGLES	±1'	LEGION ELECTRONIC & HARDWARE CO., LTD.								