

DO NOT SCALE FROM THIS PRINT

- NOTES:
1. STANDARD PART SET UP AS ASP FOR VITA 57.4.
  2. Ⓢ REPRESENTS A CRITICAL DIMENSION.
  3. MINIMUM PUSHOUT FORCE: .50 LBS.
  4. DIMENSION C12 MUST BE MEASURED USING INSPECTION FIXTURE AT-1817-836-1, USE CO-AU-WI-2003-M FOR PROCESS.
  5. ATTACH LABEL "SEAX-0001" TO EACH TAPE & REEL PACKAGE.
  6. MAXIMUM ROW TO ROW VARIATION .003[0.08], MEASURED FIRST & LAST POSITIONS ONLY, ALL ROWS.
  7. PARTS TO BE PACKAGED IN TAPE & REEL.

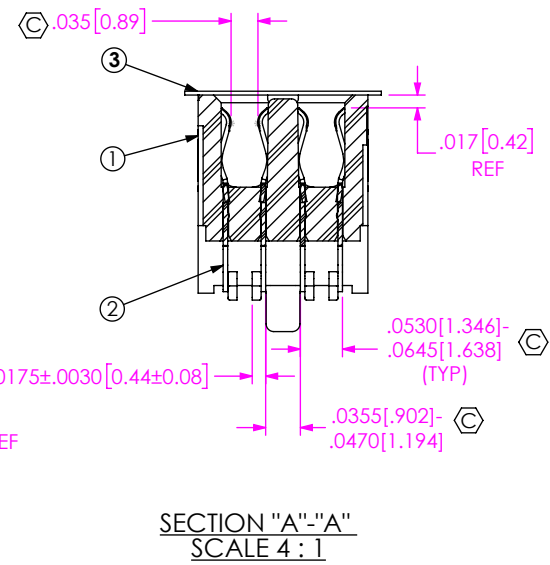
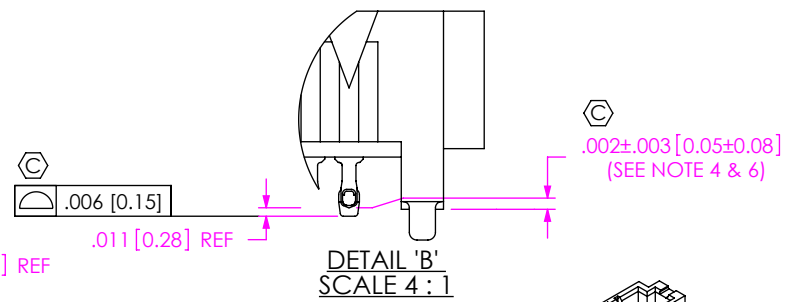
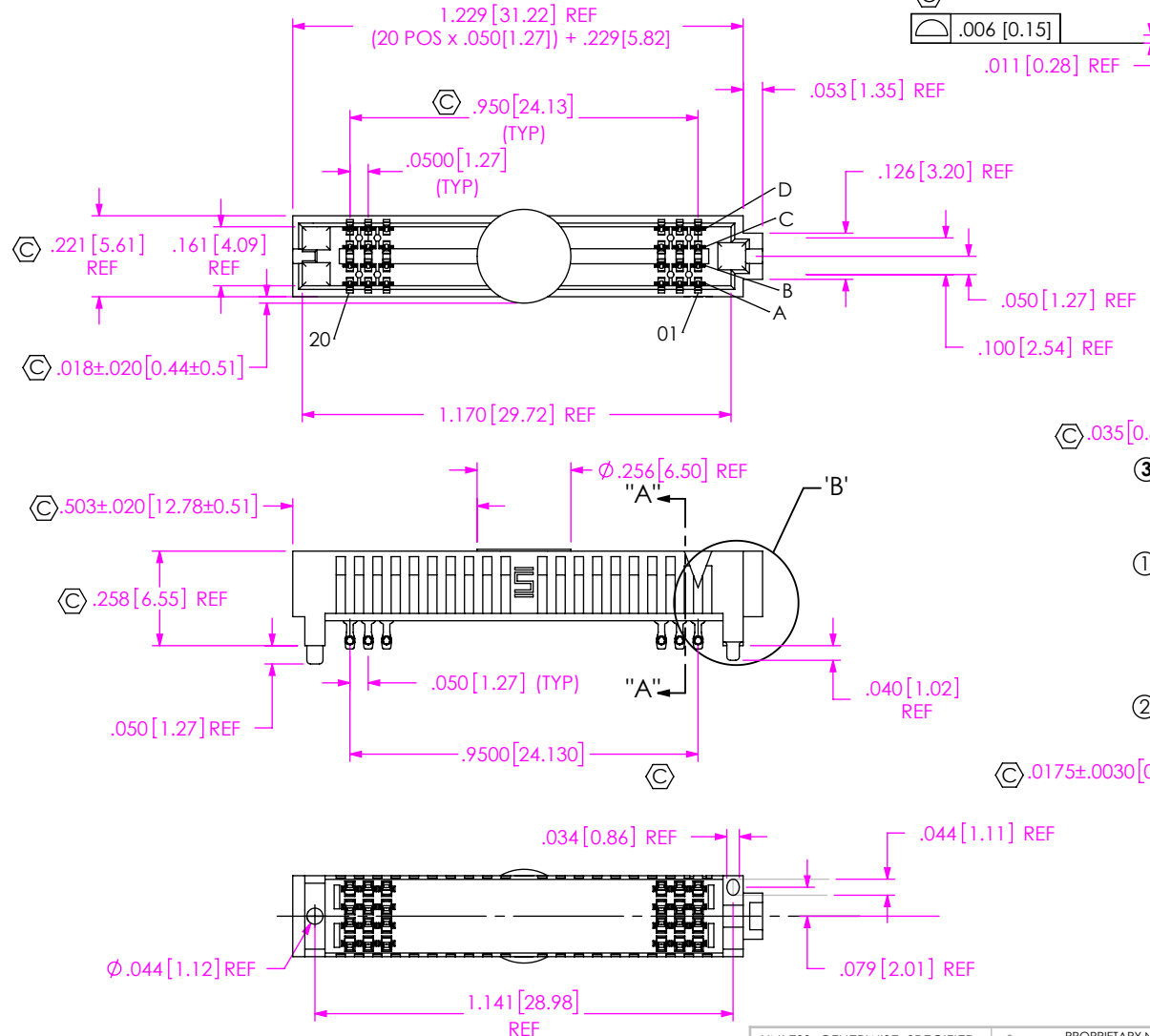

ITEM NO.	PART NUMBER	QUANTITY	MATERIAL
1	SEAF-20-06.5-04-A	1.0000	LCP, UL 94 V0, COLOR: BLACK
2	NEW-SUB-C-209-06.5-S-2	80.000	COPPER ALLOY/LEAD FREE SOLDER
3	<b>K-DOT-.256-.375-.005</b>	1.0000	POLYIMIDE FILM
4	CT-SEAF055MS	.00308	CONDUCTIVE POLYMER

UNLESS OTHERWISE SPECIFIED, DIMENSIONS ARE IN INCHES.

TOLERANCES ARE:

DECIMALS	ANGLES
.XX: ±.01 [0.3]	2°
.XXX: ±.005 [0.13]	
.XXXX: ±.0020 [0.051]	

PROPRIETARY NOTE

THIS DOCUMENT CONTAINS CONFIDENTIAL AND PROPRIETARY INFORMATION AND ALL DESIGN, MANUFACTURING, REPRODUCTION, USE, PATENT RIGHTS AND SALES RIGHTS ARE EXPRESSLY RESERVED BY SAMTEC, INC. THIS DOCUMENT SHALL NOT BE DISCLOSED, IN WHOLE OR PART, TO ANY UNAUTHORIZED PERSON OR ENTITY NOR REPRODUCED, TRANSFERRED OR INCORPORATED IN ANY OTHER PROJECT IN ANY MANNER WITHOUT THE EXPRESS WRITTEN CONSENT OF SAMTEC, INC.

DO NOT SCALE DRAWING SHEET SCALE: 2:1

PLATING:  
CONTACT AREA: .000030 GOLD OVER .000050 NICKEL  
REMAINDER: .000200 REF TIN OVER .000050 NICKEL

SOLDER: LEAD FREE Ⓢ

F:\DWG\MISC\MKTG\ASP-186899-01-MKT.SLDDRW

520 PARK EAST BLVD, NEW ALBANY, IN 47150  
PHONE: 812-944-6733 FAX: 812-948-5047  
e-Mail: info@SAMTEC.com code 55322

DESCRIPTION: .050 SOCKET ARRAY ASSEMBLY

DWG. NO. ASP-186899-01

BY: WHELAN 05/06/15 SHEET 1 OF 2

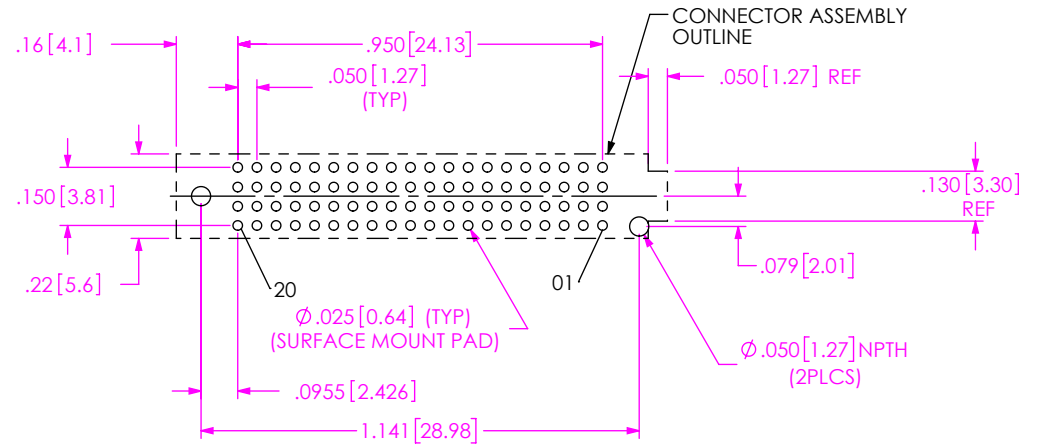
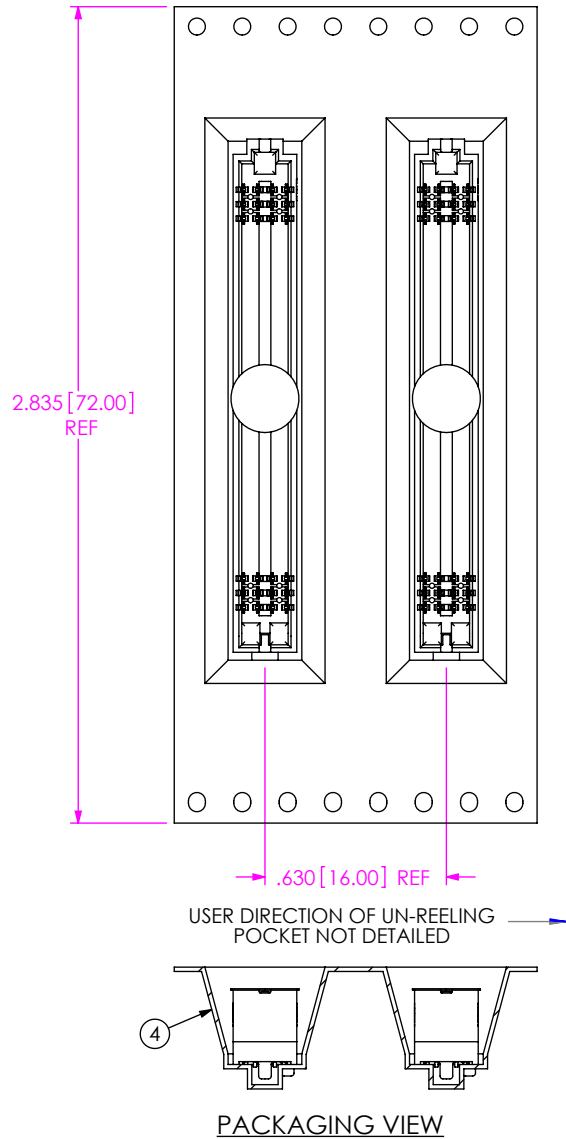

RECOMMENDED PCB LAYOUT  
SCALE 2:1

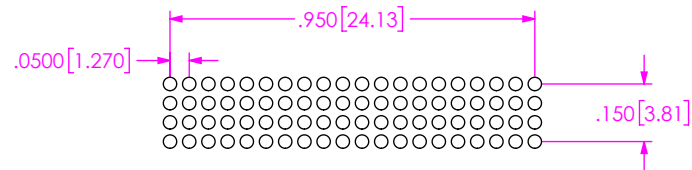

NOTE:  
STENCIL TO BE .0060 [0.152] THICK.

RECOMMENDED STENCIL LAYOUT  
SCALE 2:1

PROPRIETARY NOTE

THIS DOCUMENT CONTAINS CONFIDENTIAL AND PROPRIETARY INFORMATION AND ALL DESIGN, MANUFACTURING, REPRODUCTION, USE, PATENT RIGHTS AND SALES RIGHTS ARE EXPRESSLY RESERVED BY SAMTEC, INC. THIS DOCUMENT SHALL NOT BE DISCLOSED, IN WHOLE OR PART, TO ANY UNAUTHORIZED PERSON OR ENTITY NOR REPRODUCED, TRANSFERRED OR INCORPORATED IN ANY OTHER PROJECT IN ANY MANNER WITHOUT THE EXPRESS WRITTEN CONSENT OF SAMTEC, INC.



520 PARK EAST BLVD, NEW ALBANY, IN 47150  
PHONE: 812-944-6733 FAX: 812-948-5047  
e-Mail info@SAMTEC.com code 53322

SHEET SCALE: 3:2

DESCRIPTION:  
.050 SOCKET ARRAY ASSEMBLY

DWG. NO.  
ASP-186899-01