



CD4042 (LX) Quad Clocked D Latch

Product Specification

Specification Revision History:

Version	Date	Description
2023-06-A0	2023-06	New
2023-10-A1	2023-10	Modify parameter



Contents

1、 General Description.....	1
2、 Block Diagram And Pin Description	3
2.1、 Block Diagram.....	3
2.2、 Pin Configurations	3
2.3、 Pin Description	4
3、 Electrical Parameter	4
3.1、 Absolute Maximum Ratings	4
3.2、 Recommended Operating Conditions	4
3.3、 Electrical Characteristics	5
3.3.1、 DC Characteristics 1	5
3.3.2、 DC Characteristics 2	5
3.3.3、 AC Characteristics 1	6
3.3.4、 AC Characteristics 2	7
4、 Testing Circuit	8
4.1、 DC Testing Circuit.....	8
4.2、 AC Testing Circuit.....	8
4.3、 AC Testing Waveforms	9
4.4、 Measurement Points.....	9
5、 Package Information	10
5.1、 DIP16.....	10
5.2、 SOP16.....	11
5.3、 TSSOP16	12
6、 Statements And Notes	13
6.1、 The name and content of Hazardous substances or Elements in the product	13
6.2、 Notes.....	13



1、 General Description

The CD4042 is a quad clocked “D” latch.

It operates over a recommended V_{DD} power supply range of 3V to 15V referenced to V_{SS} (usually ground).

Unused inputs must be connected to V_{DD} , V_{SS} , or another input.

Features:

- Supply voltage range: 3V to 15V
- Temperature range: -40°C to +125°C
- Packaging information: DIP16/SOP16/SSOP16/TSSOP16



Ordering Information:

Tube packing specifications:

Part number	Packaging form	Marking code	Tube quantity	Boxed tube quantity	Boxed quantity	Notes
CD4042BE(LX)	DIP16	CD4042	25 PCS/tube	40 tube/box	1000 PCS/box	Dimensions of plastic enclosure: 19.0mm×6.4mm Pin spacing:2.54mm
CD4042BM(LX)	SOP16	CD4042	50 PCS/tube	200 tube/box	10000 PCS/box	Dimensions of plastic enclosure: 10.0mm×3.9mm Pin spacing:1.27mm
CD4042BPW(LX)	TSSOP16	CD4042	96 PCS/tube	200 tube/box	19200 PCS/box	Dimensions of plastic enclosure: 5.0mm×4.4mm Pin spacing:0.65mm

Reel packing specifications:

Part number	Packaging form	Marking code	Reel quantity	Boxed reel quantity	Notes
CD4042BM(LX)	SOP16	CD4042	4000PCS/reel	8000PCS/box	Dimensions of plastic enclosure: 10.0mm×3.9mm Pin spacing:1.27mm
CD4042BPW(LX)	TSSOP16	CD4042	5000PCS/reel	10000PCS/box	Dimensions of plastic enclosure: 5.0mm×4.4mm Pin spacing:0.65mm

Note 1: "XX" refers to variable content, meaning year and package batch serial number.

Note 2: If the physical information is inconsistent with the ordering information, please refer to the actual product.



2、Block Diagram And Pin Description

2.1、Block Diagram

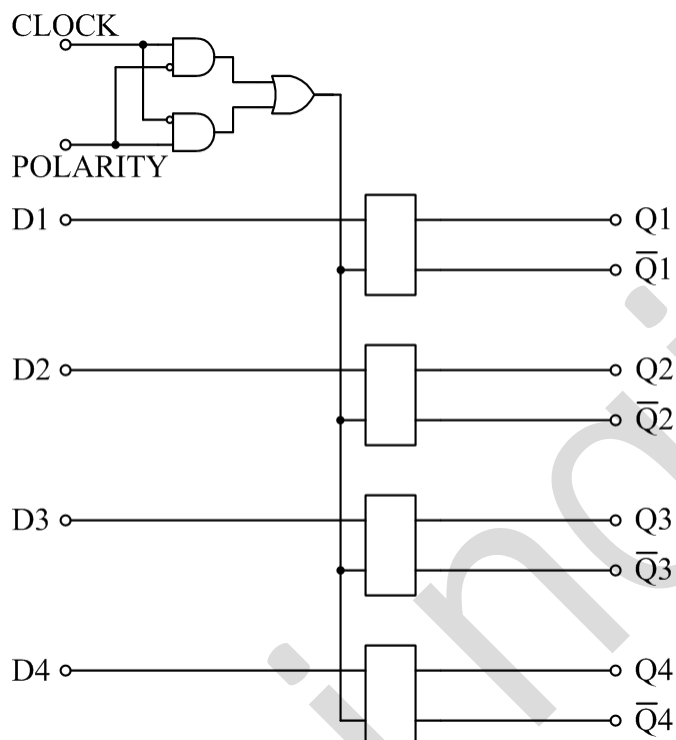
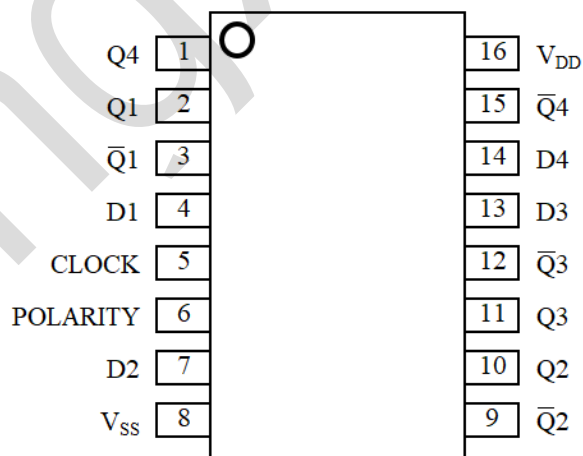

Figure 1. Functional diagram

2.2、Pin Configurations





2.3、Pin Description

Pin No.	Pin Name	Description
1	Q4	data output
2	Q1	data output
3	$\bar{Q}1$	data output
4	D1	data input
5	CLOCK	clock input
6	POLARITY	clock enable input
7	D2	data input
8	V _{SS}	ground (0V)
9	$\bar{Q}2$	data output
10	Q2	data output
11	Q3	data output
12	Q3	data output
13	D3	data input
14	D4	data input
15	$\bar{Q}4$	data output
16	V _{DD}	supply voltage

2.4、Function Table

Input		Output
CLOCK	POLARITY	Q
0	0	D
1	0	LATCH
1	1	D
0	1	LATCH

3、Electrical Parameter

3.1、Absolute Maximum Ratings

(T_{amb}=25°C, All voltage referenced to V_{SS}, unless otherwise specified)

Parameter	Symbol	Conditions	Min.	Max.	Unit
supply voltage	V _{DD}	-	-0.5	+18	V
input voltage	V _I	all inputs	-0.5	V _{DD} +0.5	V
DC input current	I _{IK}	any one input	-	±10	mA
storage temperature	T _{stg}	-	-65	+150	°C
soldering temperature	T _L	10s	DIP		245
			SOP/SSOP/TSSOP		260

3.2、Recommended Operating Conditions

Parameter	Symbol	Conditions	Min.	Typ.	Max.	Unit
supply voltage	V _{DD}	-	3	-	15	V
ambient temperature	T _{amb}	in free air	-40	-	+125	°C



3.3、Electrical Characteristics

3.3.1、DC Characteristics 1

($T_{amb} = -40^{\circ}\text{C}$ to $+85^{\circ}\text{C}$, voltages are referenced to V_{SS} (ground=0V), unless otherwise specified.)

Parameter	Symbol	V_{DD}	Conditions	Min.	Typ.	Max.	Unit
HIGH-level input voltage	V_{IH}	5V	-	3.5	-	-	V
		10V	-	7	-	-	V
		15V	-	11	-	-	V
LOW-level input voltage	V_{IL}	5V	-	-	-	1.5	V
		10V	-	-	-	3	V
		15V	-	-	-	4	V
HIGH-level output voltage	V_{OH}	5V	$ I_o < 1\mu\text{A}$	4.95	-	-	V
		10V	$ I_o < 1\mu\text{A}$	9.95	-	-	V
		15V	$ I_o < 1\mu\text{A}$	14.95	-	-	V
LOW-level output voltage	V_{OL}	5V	$ I_o < 1\mu\text{A}$	-	-	0.05	V
		10V	$ I_o < 1\mu\text{A}$	-	-	0.05	V
		15V	$ I_o < 1\mu\text{A}$	-	-	0.05	V
HIGH-level output current	I_{OH}	5V	$V_o = 4.6\text{V}$	-	-	-0.34	mA
		5V	$V_o = 2.5\text{V}$	-	-	-1.3	mA
		10V	$V_o = 9.5\text{V}$	-	-	-0.55	mA
		15V	$V_o = 13.5\text{V}$	-	-	-1.65	mA
LOW-level output current	I_{OL}	5V	$V_o = 0.4\text{V}$	0.34	-	-	mA
		10V	$V_o = 0.5\text{V}$	0.46	-	-	mA
		15V	$V_o = 1.5\text{V}$	1.4	-	-	mA
input leakage current	I_I	15V	$V_I = 15\text{V}$ or V_{SS}	-	-	± 1	μA
supply current	I_{DD}	5V	$V_I = 5\text{V}$ or $V_{SS}; I_o = 0\text{A}$	-	-	30	μA
		10V	$V_I = 10\text{V}$ or $V_{SS}; I_o = 0\text{A}$	-	-	60	μA
		15V	$V_I = 15\text{V}$ or $V_{SS}; I_o = 0\text{A}$	-	-	120	μA

3.3.2、DC Characteristics 2

($T_{amb} = -40^{\circ}\text{C}$ to $+125^{\circ}\text{C}$, voltages are referenced to V_{SS} (ground=0V), unless otherwise specified.)

Parameter	Symbol	V_{DD}	Conditions	Min.	Typ.	Max.	Unit
HIGH-level input voltage	V_{IH}	5V	-	3.5	-	-	V
		10V	-	7	-	-	V
		15V	-	11	-	-	V
LOW-level input voltage	V_{IL}	5V	-	-	-	1.5	V
		10V	-	-	-	3	V
		15V	-	-	-	4	V
HIGH-level output voltage	V_{OH}	5V	$ I_o < 1\mu\text{A}$	4.95	-	-	V
		10V	$ I_o < 1\mu\text{A}$	9.95	-	-	V
		15V	$ I_o < 1\mu\text{A}$	14.95	-	-	V
LOW-level output voltage	V_{OL}	5V	$ I_o < 1\mu\text{A}$	-	-	0.05	V
		10V	$ I_o < 1\mu\text{A}$	-	-	0.05	V
		15V	$ I_o < 1\mu\text{A}$	-	-	0.05	V



HIGH-level output current	I _{OH}	5V	V _O =4.6V	-	-	-0.3	mA
		5V	V _O =2.5V	-	-	-1.15	mA
		10V	V _O =9.5V	-	-	-0.45	mA
		15V	V _O =13.5V	-	-	-1.4	mA
LOW-level output current	I _{OL}	5V	V _O =0.4V	0.29	-	-	mA
		10V	V _O =0.5V	0.38	-	-	mA
		15V	V _O =1.5V	1.2	-	-	mA
input leakage current	I _I	15V	V _I =15V or V _{SS}	-	-	±1	uA
supply current	I _{DD}	5V	V _I =5V or V _{SS} ; I _O =0A	-	-	30	uA
		10V	V _I =10V or V _{SS} ; I _O =0A	-	-	60	uA
		15V	V _I =15V or V _{SS} ; I _O =0A	-	-	120	uA

3.3.3、AC Characteristics 1

(T_{amb}=-40°C to +85°C, V_{SS}=0V, unless otherwise specified.)

Parameter	Symbol	V _{DD}	Conditions	Min.	Typ.	Max.	Unit
Data in to Q propagation delay time		5V	C _L =50pF, R _L =200kΩ see Figure 3	-	110	220	ns
		10V		-	55	110	ns
		15V		-	40	80	ns
Data in to \bar{Q} propagation delay time		5V	C _L =50pF, R _L =200kΩ see Figure 3	-	150	300	ns
		10V		-	75	150	ns
		15V		-	50	100	ns
Clock to Q propagation delay time	t _{PHL} , t _{PLH}	5V	C _L =50pF, R _L =200kΩ see Figure 3	-	225	450	ns
		10V		-	100	200	ns
		15V		-	80	160	ns
Clock to \bar{Q} propagation delay time		5V	C _L =50pF, R _L =200kΩ see Figure 3	-	250	500	ns
		10V		-	115	230	ns
		15V		-	90	180	ns
transition time	t _{THL} , t _{TLH}	5V	C _L =50pF, R _L =200kΩ see Figure 3	-	100	200	ns
		10V		-	50	100	ns
		15V		-	40	80	ns
Minimum clock width	t _w	5V	C _L =50pF, R _L =200kΩ see Figure 4	-	100	200	ns
		10V		-	50	100	ns
		15V		-	30	60	ns
Minimum hold time	t _h	5V	C _L =50pF, R _L =200kΩ see Figure 4	-	60	120	ns
		10V		-	30	60	ns
		15V		-	25	50	ns
Minimum setup time	t _{su}	5V	C _L =50pF, R _L =200kΩ see Figure 4	-	0	50	ns
		10V		-	0	30	ns
		15V		-	0	25	ns



3.3.4、AC Characteristics 2

($T_{amb} = -40^{\circ}\text{C}$ to $+125^{\circ}\text{C}$, $V_{SS} = 0\text{V}$, unless otherwise specified.)

Parameter	Symbol	V_{DD}	Conditions	Min.	Typ.	Max.	Unit
Data in to Q propagation delay time	t_{PHL}, t_{PLH}	5V	$C_L = 50\text{pF}, R_L = 200\text{k}\Omega$ see Figure 3	-	-	264	ns
		10V		-	-	132	ns
		15V		-	-	96	ns
Data in to \bar{Q} propagation delay time		5V	$C_L = 50\text{pF}, R_L = 200\text{k}\Omega$ see Figure 3	-	-	360	ns
		10V		-	-	180	ns
		15V		-	-	120	ns
Clock to Q propagation delay time		5V	$C_L = 50\text{pF}, R_L = 200\text{k}\Omega$ see Figure 3	-	-	540	ns
		10V		-	-	240	ns
		15V		-	-	192	ns
Clock to \bar{Q} propagation delay time	5V	$C_L = 50\text{pF}, R_L = 200\text{k}\Omega$ see Figure 3	-	-	600	ns	
	10V		-	-	276	ns	
	15V		-	-	216	ns	
transition time	t_{THL}, t_{TLH}	5V	$C_L = 50\text{pF}, R_L = 200\text{k}\Omega$ see Figure 3	-	-	240	ns
		10V		-	-	120	ns
		15V		-	-	96	ns
Minimum clock width	t_w	5V	$C_L = 50\text{pF}, R_L = 200\text{k}\Omega$ see Figure 4	-	-	240	ns
		10V		-	-	120	ns
		15V		-	-	72	ns
Minimum hold time	t_h	5V	$C_L = 50\text{pF}, R_L = 200\text{k}\Omega$ see Figure 4	-	-	144	ns
		10V		-	-	72	ns
		15V		-	-	60	ns
Minimum setup time	t_{su}	5V	$C_L = 50\text{pF}, R_L = 200\text{k}\Omega$ see Figure 4	-	-	60	ns
		10V		-	-	36	ns
		15V		-	-	30	ns



4、Testing Circuit

4.1、DC Testing Circuit

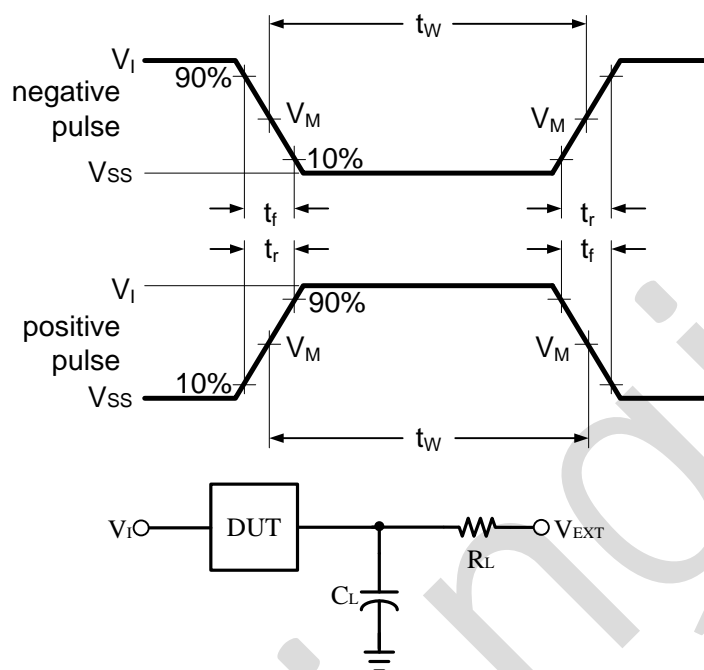

Figure 2. Load circuit

C_L includes probe and jig capacitance.

4.2、AC Testing Circuit

Supply voltage	Input		Load		V_{EXT}		
V_{DD}	V_I	$t_r = t_f$	C_L	R_L	t_{PLH}/t_{PHL}	t_{PLZ}/t_{PZL}	t_{PHZ}/t_{PZH}
5V to 15V	V_{CC}	20ns	50pF	200k Ω	Open	V_{DD}	V_{SS}

4.3、AC Testing Waveforms

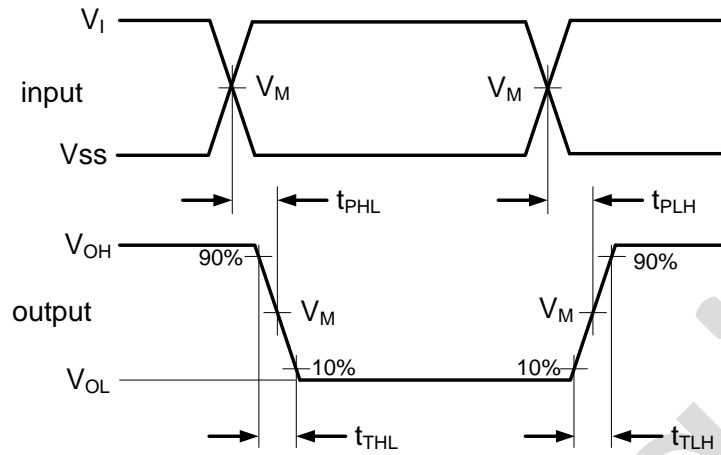

Figure 3. Propagation delay and output transition time

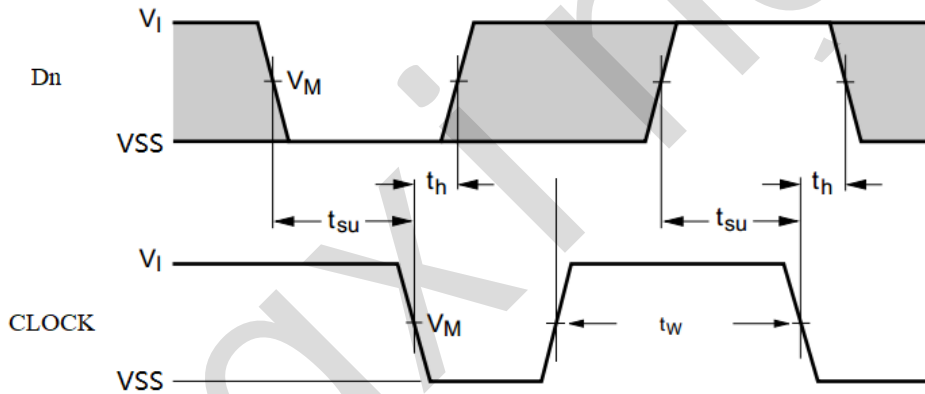

Figure 4. set_up time, hold time and pulse width

4.4、Measurement Points

Supply voltage	Input	Output		
V_{DD}	V_M	V_M	V_X	V_Y
5V to 15V	$0.5 \times V_{DD}$	$0.5 \times V_{DD}$	$0.1 \times V_{DD}$	$0.9 \times V_{DD}$



5、Package Information

5.1、DIP16

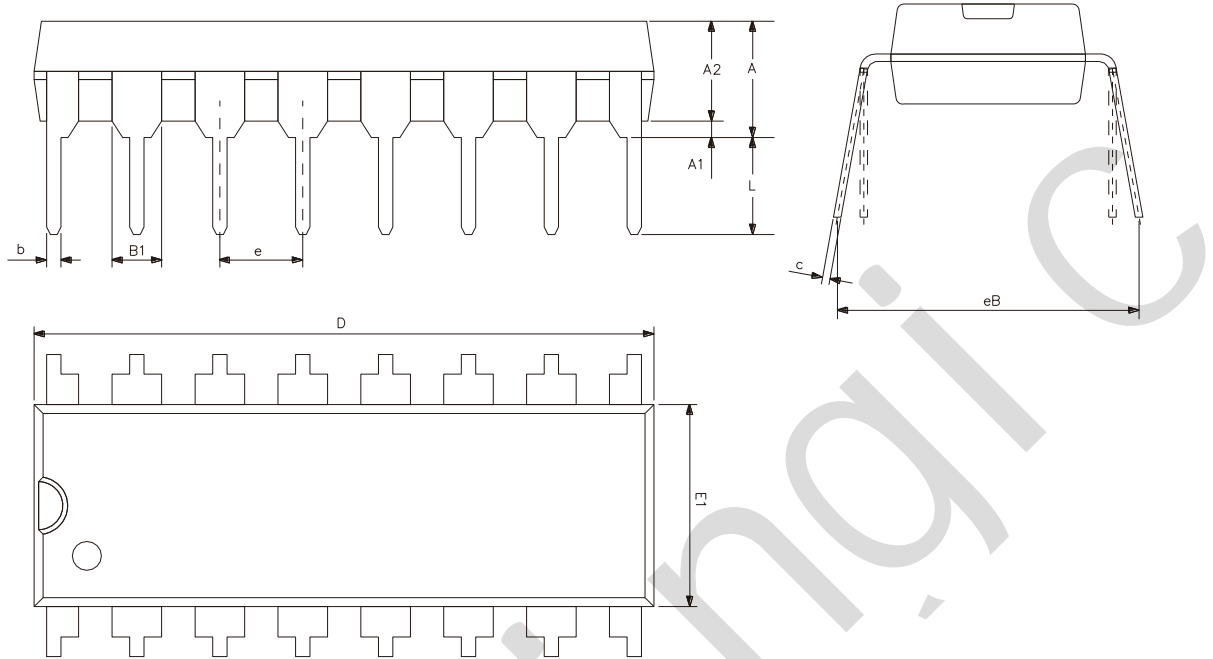

Symbol	Dimensions (mm)	
	Min.	Max.
A2	3.20	3.60
A1	0.51	-
A	3.60	5.33
L	3.00	3.60
b	0.36	0.56
B1	1.52	
D	18.80	19.94
E1	6.20	6.60
e	2.54	
c	0.20	0.36
eB	7.62	9.30



5.2、SOP16

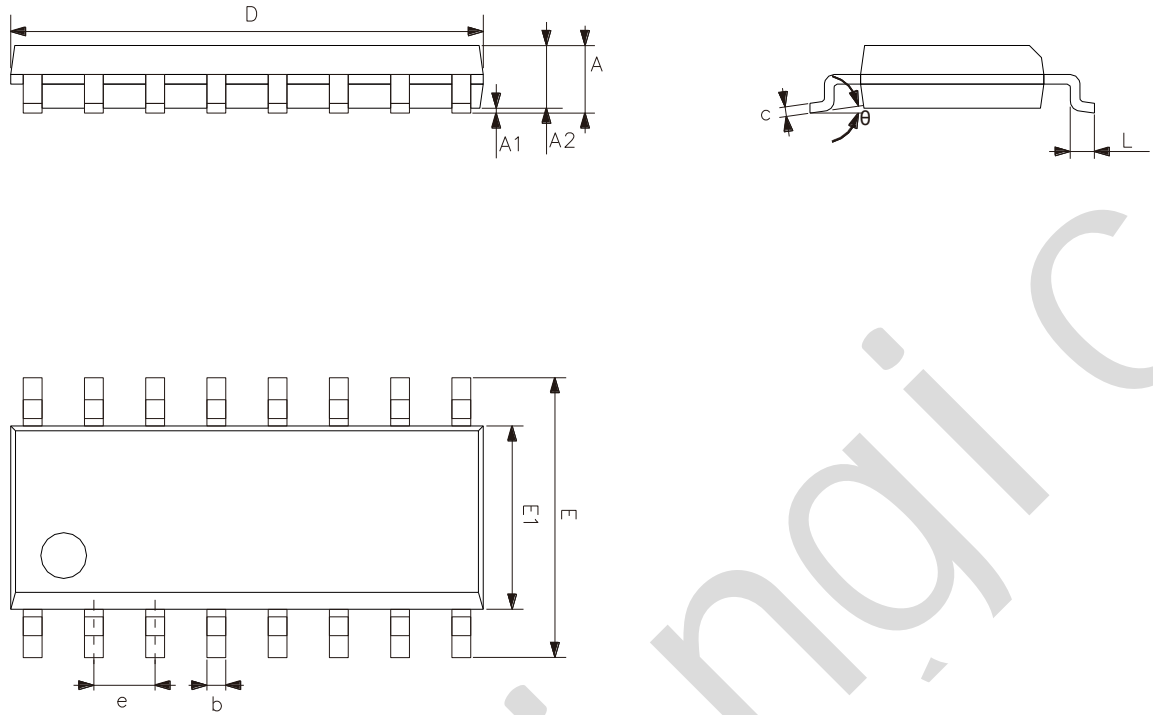

Symbol	Dimensions (mm)	
	Min.	Max.
A	1.35	1.80
A1	0.10	0.25
A2	1.25	1.55
b	0.33	0.51
c	0.19	0.25
D	9.50	10.10
E	5.80	6.30
E1	3.70	4.10
e	1.27	
L	0.35	0.89
θ	0°	8°



5.3、TSSOP16

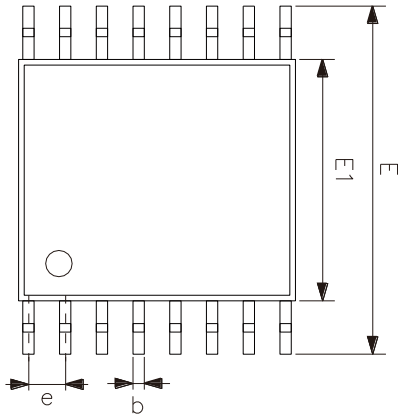
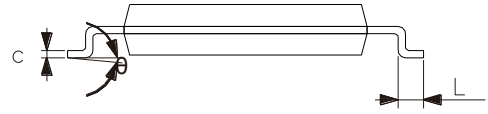
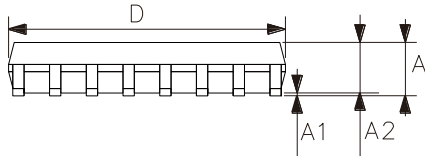

Symbol	Dimensions (mm)	
	Min.	Max.
A	-	1.20
A1	0.05	0.15
A2	0.80	1.05
b	0.19	0.30
c	0.09	0.20
D	4.90	5.10
E1	4.30	4.50
E	6.20	6.60
e	0.65	
L	0.45	0.75
θ	0°	8°



6、 Statements And Notes

6.1、 The name and content of Hazardous substances or Elements in the product

Part name	Hazardous substances or Elements									
	Lead and lead compounds	Mercury and mercury compounds	Cadmium and cadmium compounds	Hexavalent chromium compounds	Polybrominated biphenyls	Polybrominated biphenyl ethers	Dibutyl phthalate	Butylbenzyl phthalate	Di-2-ethylhexyl phthalate	Diisobutyl phthalate
Lead frame	○	○	○	○	○	○	○	○	○	○
Plastic resin	○	○	○	○	○	○	○	○	○	○
Chip	○	○	○	○	○	○	○	○	○	○
The lead	○	○	○	○	○	○	○	○	○	○
Plastic sheet installed	○	○	○	○	○	○	○	○	○	○
explanation	○: Indicates that the content of hazardous substances or elements in the detection limit of the following the SJ/T11363-2006 standard. ×: Indicates that the content of hazardous substances or elements exceeding the SJ/T11363-2006 Standard limit requirements.									

6.2、 Notes

We recommend you to read this chapter carefully before using this product.

The information in this chapter is provided for reference only and Lingxing disclaims any express or implied warranties, including but not limited to applicability, special application or non-infringement of third party rights.

This product is not suitable for critical equipment such as life-saving, life-sustaining or safety equipment. It is also not suitable for applications that may result in personal injury, death, or serious property or environmental damage due to product malfunction or failure. Lingxing will not be liable for any damages incurred by the customers at their own risk for such applications.

The customer is responsible for conducting all necessary tests Lingxing's application to avoid failure in the application or the application of the customer's third party users. Lingxing does not accept any liability.

The Company reserves the right to change or improve the information published in this chapter at any time. The information in this chapter are subject to change without notice. We recommend the customer to consult our sales staff before purchasing.

Please obtain related materials form Lingxing's regular channels and we are not responsible for its content if it is provided by sources other than our company.

In case of any conflict between the Chinese and English version, the version is subject to the Chinese one.