

2 Pin样式

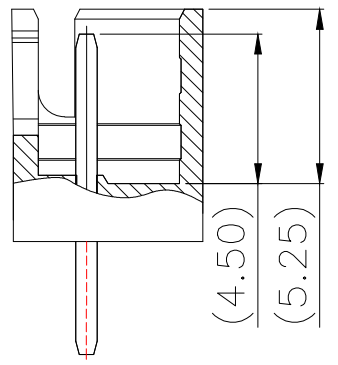

SECTION A-A

Part No	Pin	A	B
WAFER-XH2.54-2PZZ-R62	2	2.5	7.5
WAFER-XH2.54-3PZZ-R62	3	5.0	10.0
WAFER-XH2.54-4PZZ-R62	4	7.5	12.5
WAFER-XH2.54-5PZZ-R62	5	10.0	15.0
WAFER-XH2.54-6PZZ-R62	6	12.5	17.5
WAFER-XH2.54-7PZZ-R62	7	15.0	20.0
WAFER-XH2.54-8PZZ-R62	8	17.5	22.5
WAFER-XH2.54-9PZZ-R62	9	20.0	25.0
WAFER-XH2.54-10PZZ-R62	10	22.5	27.5
WAFER-XH2.54-11PZZ-R62	11	25.0	30.0
WAFER-XH2.54-12PZZ-R62	12	27.5	32.5
WAFER-XH2.54-13PZZ-R62	13	30.0	35.0
WAFER-XH2.54-14PZZ-R62	14	32.5	37.5
WAFER-XH2.54-15PZZ-R62	15	35.0	40.0
WAFER-XH2.54-16PZZ-R62	16	37.5	42.5

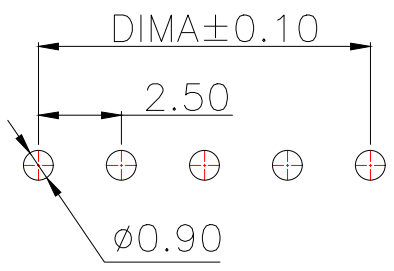
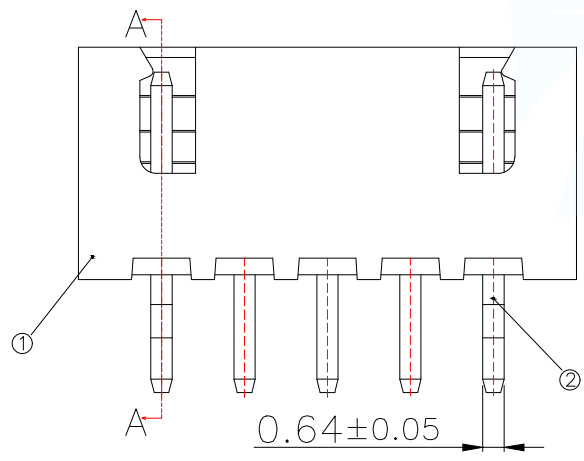

适用线路板(PCB LAYOUT)

Technical Index:
 1. Temperature range: -25°C~85°C.
 2. Rated voltage: 250V DC/AC(rms).
 3. Rated current: 3.0A.
 4. Contact resistance: ≤20mΩ.
 5. Withstanding voltage: 1000V AC/minute.
 6. Insulation resistance: ≥1000MΩ.

序号	品名	材质
1	XH2.5 嵌芯	PA66 UL94V-2 Red
2	XH2.5 直针 端子	Copper Alloy/ Tin Plating

MANUFACTURE DWG			东莞市讯普电子科技有限公司 DongGuan XunPu Electronics Co.,Ltd	
UNLESS OTHERWISE SPECIFIED TOLERANCES			TITLE: XH2.5 直针	
DECIMALS:	ANGLES:		PAR	WAFER-XH2.54-NPZZ-R62
.X:±0.50	X':±5°		DWN	
.X:±0.20	X.X':±3°	CHKD		
.XX:±0.10	X.XX':±1°	APVD		
CUSTOMER COPY		SCALE:1:1	UNIT:MM	
		SIZE:A4	SHEET:1F1	REV:A