

Technical Index:
 1. Temperature range: $-25^{\circ}\text{C}\sim 85^{\circ}\text{C}$.
 2. Rated voltage: 200V DC/AC(rms).
 3. Rated current: 2.0A.
 4. Contact resistance: $\leq 25\text{m}\Omega$.
 5. Withstanding voltage: 500V AC/minute.
 6. Insulation resistance: $\geq 1000\text{M}\Omega$.

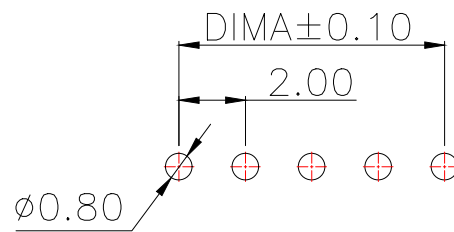
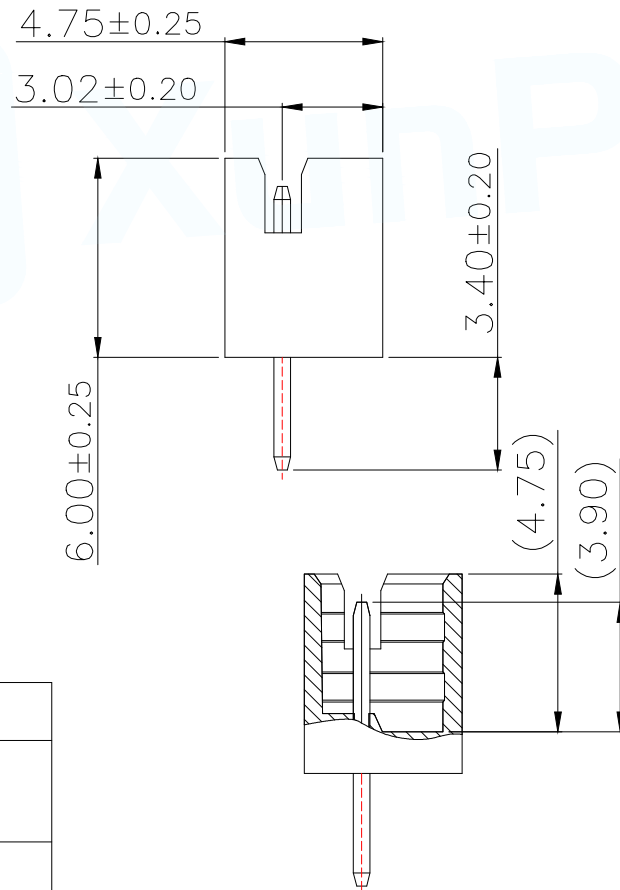
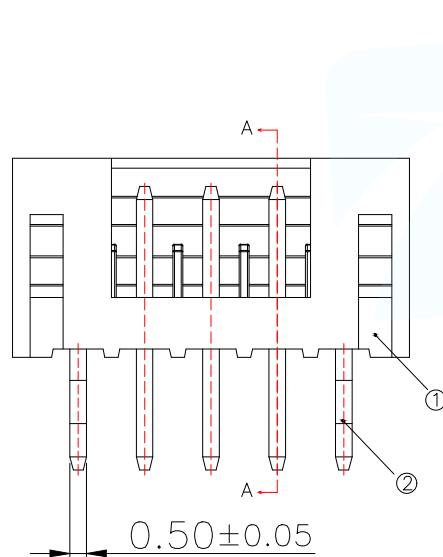

适用线路板(PCB LAYOUT)

Part No	Pin	A	B
WAFER-PH2.0-2PZZ-H62	2	2.00	6.00
WAFER-PH2.0-3PZZ-H62	3	4.00	8.00
WAFER-PH2.0-4PZZ-H62	4	6.00	10.00
WAFER-PH2.0-5PZZ-H62	5	8.00	12.00
WAFER-PH2.0-6PZZ-H62	6	10.00	14.00
WAFER-PH2.0-7PZZ-H62	7	12.00	16.00
WAFER-PH2.0-8PZZ-H62	8	14.00	18.00
WAFER-PH2.0-9PZZ-H62	9	16.00	20.00
WAFER-PH2.0-10PZZ-H62	10	18.00	22.00
WAFER-PH2.0-11PZZ-H62	11	20.00	24.00
WAFER-PH2.0-12PZZ-H62	12	22.00	26.00
WAFER-PH2.0-13PZZ-H62	13	24.00	28.00
WAFER-PH2.0-14PZZ-H62	14	26.00	30.00
WAFER-PH2.0-15PZZ-H62	15	28.00	32.00
WAFER-PH2.0-16PZZ-H62	16	30.00	34.00
WAFER-PH2.0-17PZZ-H62	17	32.00	36.00
WAFER-PH2.0-18PZZ-H62	18	34.00	38.00
WAFER-PH2.0-19PZZ-H62	19	36.00	40.00
WAFER-PH2.0-20PZZ-H62	20	38.00	42.00

序号	品名	材质
1	PH2.0 直针 胶芯	PA66 UL94V-2 Yellow
2	PH2.0 直针 端子	Copper Alloy/ Tin Plating

SECTION A-A

MANUFACTURE DWG			东莞市讯普电子科技有限公司 DongGuan XunPu Electronics Co.,Ltd	
UNLESS OTHERWISE SPECIFIED TOLERANCES			TITLE: PH2.0 直针	
DECIMALS:	ANGLES:	CUSTOMER COPY	PAR	WAFER-PH2.0-NPZZ-H62
X.:±0.50	X'::±5°		DWN	
.X:±0.20	X.X'::±3°		CHKD	
.XX:±0.10	X.XX'::±1°		APVD	
		SCALE:1:1	UNIT:MM	
		SIZE:A4	SHEET:1F1	REV:A