

DIGITAL TRANSISTOR (NPN)

Digital Transistors (Built-in Resistors)

FEATURES

- Built-in bias resistors enable the configuration of an inverter circuit without connecting external input resistors(see equivalent circuit)
- The bias resistors consist of thin-film resistors with complete isolation to allow negative biasing of the input.They also have the advantage of almost completely eliminating parasitic effects
- Only the on/off conditions need to be set for operation, making device design easy

• Equivalent Circuit

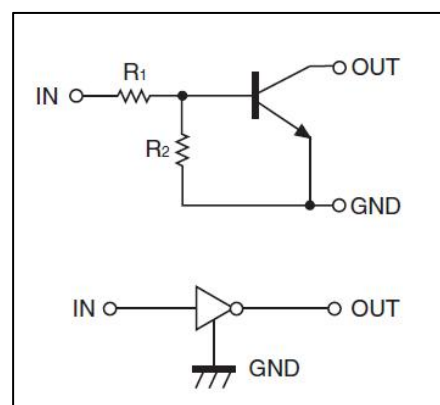

PIN CONNENCTIONS and MARKING

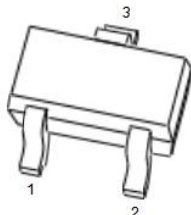
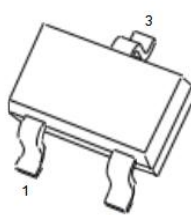
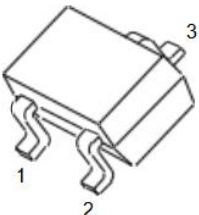
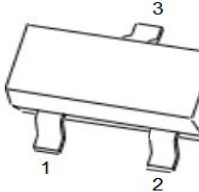
DTC124EE 	SOT-523 1. IN 2. GND 3. OUT	DTC124EUA 	SOT-323 1. IN 2. GND 3. OUT
DTC124EKA 	SOT-23-3L 1. IN 2. GND 3. OUT	DTC124ECA 	SOT-23 1. IN 2. GND 3. OUT

ORDERING INFORMATION

Part Number	MARKING ⁽¹⁾	Package	Packing Method	Pack Quantity
DTC124EE	25	SOT-523	Reel	3000pcs/Reel
DTC124EUA	25	SOT-323	Reel	3000pcs/Reel
DTC124EKA	25	SOT-23-3L	Reel	3000pcs/Reel
DTC124ECA	25	SOT-23	Reel	3000pcs/Reel

MAXIMUM RATINGS(Ta=25°C unless otherwise noted)

Symbol	Parameter	Limits(DTC124E□)						Unit
		M	E	UA	KA	CA	SA	
V _{CC}	Supply Voltage	50						V
V _{IN}	Input Voltage	-10~+40						V
I _O	Output Current	30						mA
I _{CM}	Peak Collector Current	100						mA
P _D	Power Dissipation	100	150	200	200	200	300	mW
T _J , T _{stg}	Operation Junction and Storage Temperature Range	-55~+150						°C

ELECTRICAL CHARACTERISTICS (Ta=25°C unless otherwise specified)

Parameter	Symbol	Conditions	Min	Typ	Max	Unit
Input voltage	V _{I(off)}	V _{CC} =5V, I _O =100μA	0.5			V
	V _{I(on)}	V _O =0.2V, I _O =5mA			3	V
Output voltage	V _{O(on)}	I _O /I _I =10mA/0.5mA		0.1	0.3	V
Input current	I _I	V _I =5V			0.36	mA
Output current	I _{O(off)}	V _{CC} =50V, V _I =0			0.5	μA
DC current gain	G _I	V _O =5V, I _O =5mA	56			
Input resistance	R ₁		15.4	22	28.6	kΩ
Resistance ratio	R ₂ /R ₁		0.8	1	1.2	
Transition frequency	f _T	V _O =10V, I _O =5mA, f=100MHz		250		MHz

Typical Characteristics

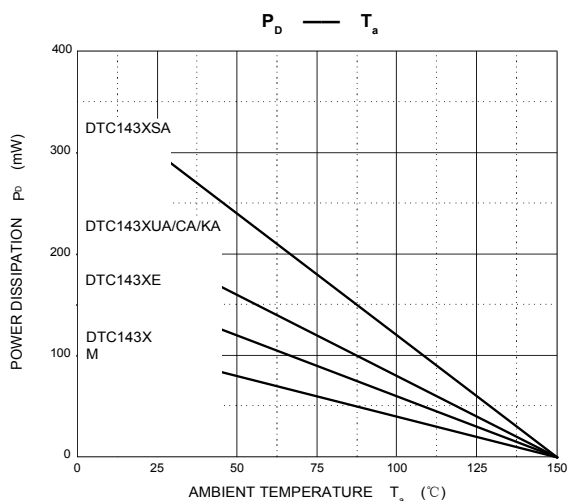
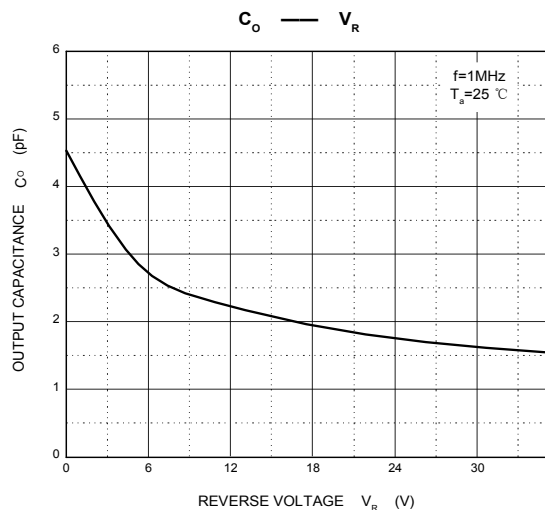
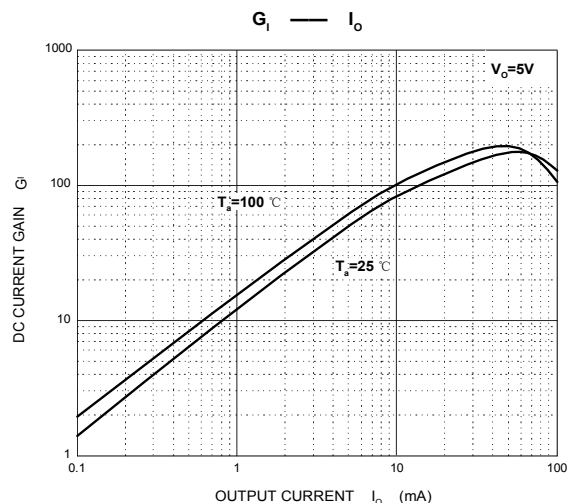
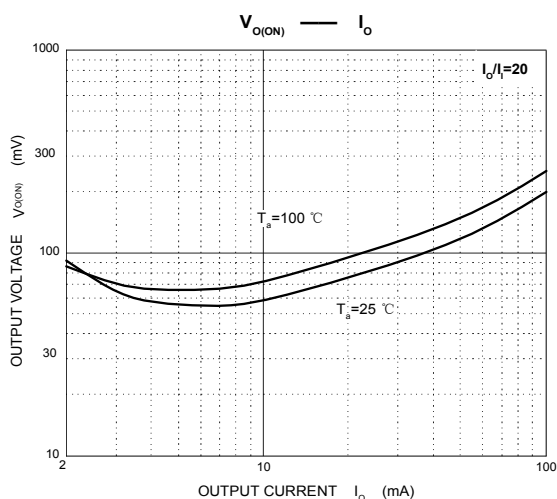
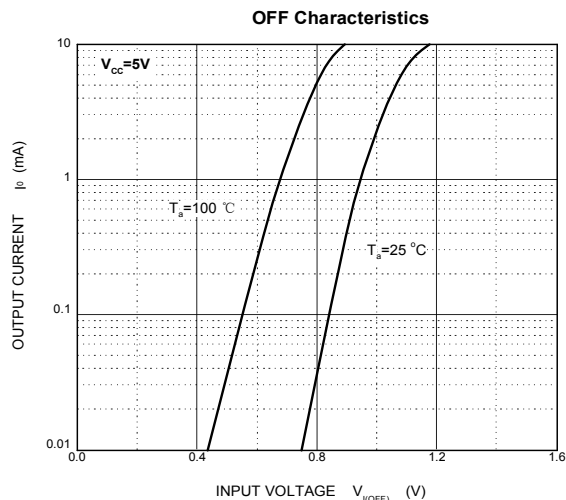
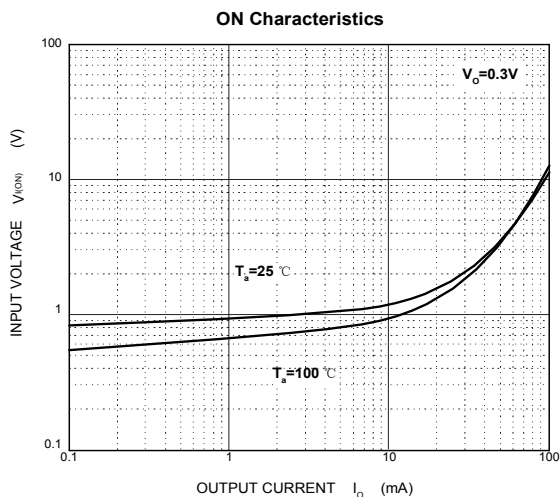

PACKAGE OUTLINE

Plastic surface mounted package; 3 leads

SOT-523

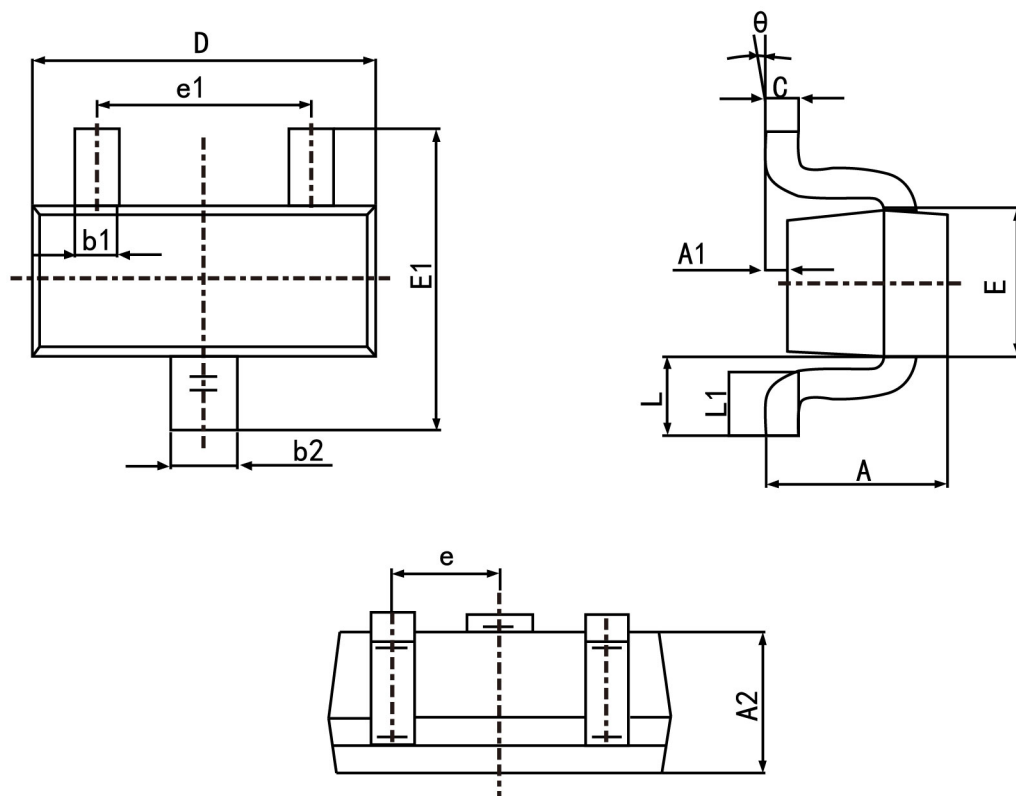

Symbol	Dimension in Millimeters	
	Min	Max
A	0.700	0.900
A1	0.000	0.100
A2	0.700	0.800
b1	0.150	0.250
b2	0.250	0.350
c	0.100	0.200
D	1.500	1.700
E	0.700	0.900
E1	1.450	1.750
e	0.500	TYP.
e1	0.900	1.100
L	0.400 REF.	
L1	0.260	0.460
θ	0°	8°

PACKAGE OUTLINE

Plastic surface mounted package; 3 leads

SOT-323

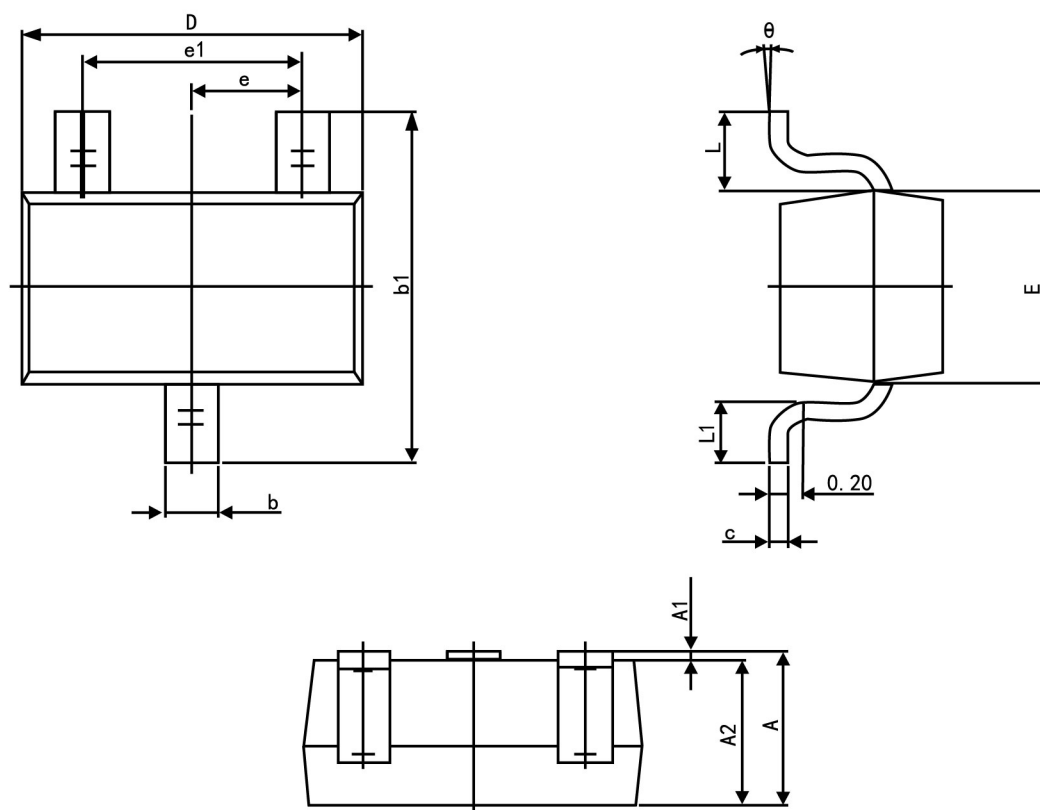

Symbol	Dimension in Millimeters	
	Min	Max
A	0.900	1.100
A1	0.000	0.100
A2	0.900	1.000
b	0.200	0.400
c	0.080	0.150
D	2.000	2.200
E	1.150	1.350
E1	2.150	2.450
e	0.650 TYP.	
e1	1.200	1.400
L	0.525 REF.	
L1	0.260	0.460
θ	0°	8°

Package outline dimensions SOT23-3L

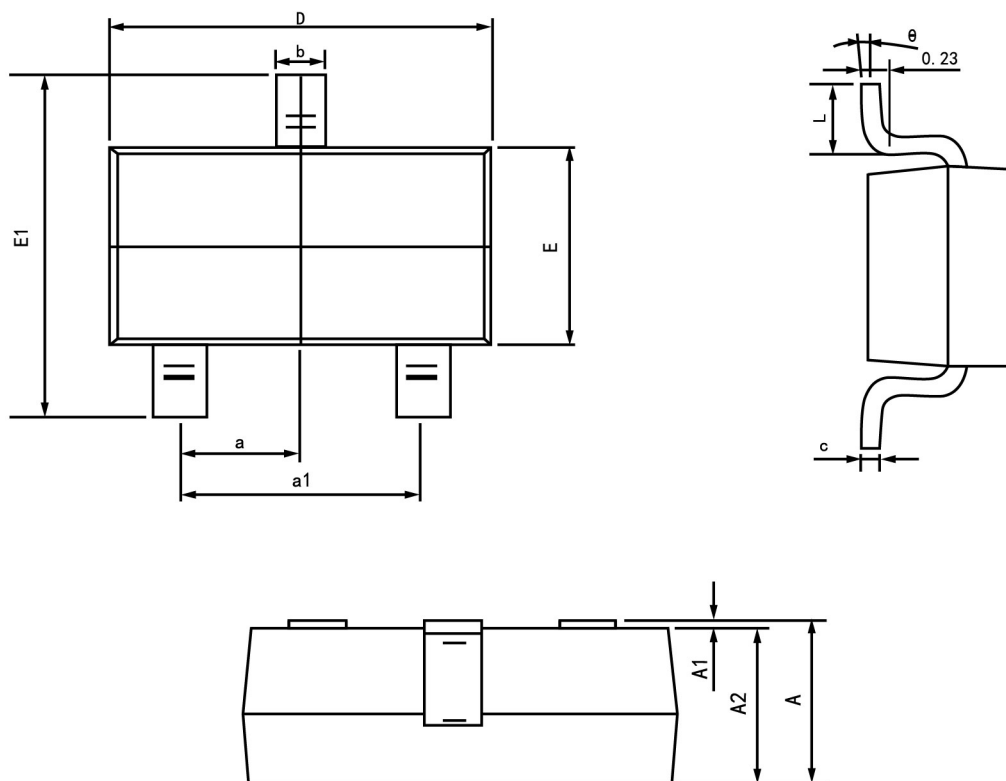

Symbol	Dimension in Millimeters	
	Min	Max
A	1.050	1.250
A1	0.000	0.100
A2	1.050	1.150
b	0.300	0.500
c	0.100	0.200
D	2.820	3.020
E	1.500	1.700
E1	2.650	2.950
e	0.950 (Basic)	
e1	1.800	2.000
L	0.300	0.600
θ	0°	8°

PACKAGE OUTLINE

Plastic surface mounted package; 3 leads

SOT-23

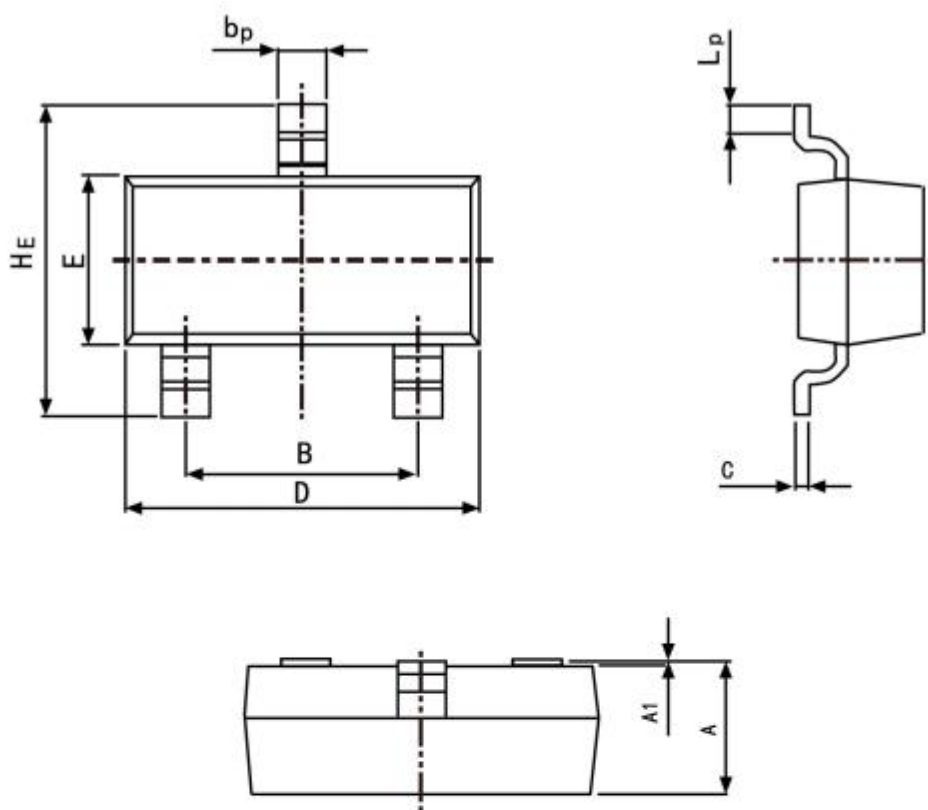

Symbol	Dimension in Millimeters	
	Min	Max
A	0.95	1.40
B	1.78	2.04
b_p	0.35	0.50
C	0.08	0.19
D	2.70	3.10
E	1.20	1.65
HE	2.20	3.00
A_1	0.100	0.013
L_p	0.20	0.50