



WGF13005

Features:

- High Voltage Capability
- High Switching Speed
- Suitable for Electronic Ballast and Switching Mode Power Supply
- 100% Avalanche Tested

TO-220F

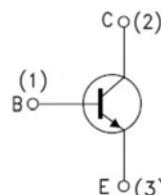

1. Base (B)
2. Collector (C)
3. Emitter (E)

Absolute Maximum Ratings*

T_c = 25°C unless otherwise noted

Symbol	Parameter	Value	Units
V _{CBO}	Collector-Base Voltage	720	V
V _{CEO}	Collector-Emitter Voltage	450	V
V _{EBO}	Emitter-Base Voltage	12	V
I _C	Collector Current (DC)	4	A
I _{CP}	Collector Current (Pulse)	8	A
I _B	Base Current	2	A
P _C	Collector Dissipation (T _C = 25°C)	70	W
T _J	Junction Temperature	150	°C
T _{STG}	Storage Temperature	-65 ~ 150	°C

Electrical Characteristics

T_c = 25°C unless otherwise noted

Symbol	Parameter	Test Condition	Min.	Typ.	Max.	Units
BV _{CBO}	Collector-Base Breakdown Voltage	I _C = 50μA, I _E = 0	850			V
BV _{CEO}	Collector-Emitter Breakdown Voltage	I _C = 5mA, I _B = 0	450			V
BV _{EBO}	Emitter-Base Breakdown Voltage	I _E = 1mA, I _C = 0	12			V
I _{CES}	Collector Cut-off Current	V _{CE} = 720V, V _{EB} = 0			1	mA
I _{CEO}	Collector Cut-off Current	V _{CE} = 400V, I _B = 0			5	mA
I _{EBO}	Emitter Cut-off Current	V _{EB} = 9V, I _C = 0			5	mA
h _{FE}	DC Current Gain	V _{CE} = 5V, I _C = 5mA V _{CE} = 5V, I _C = 2A	19 15		23 18	
V _{CE(sat)}	Collector-Emitter Saturation Voltage	I _C = 4.0A, I _B = 1.0A I _C = 5.0A, I _B = 1.0A			0.7 1.2	V
V _{BE(sat)}	Base-Emitter Saturation Voltage	I _C = 5.0A, I _B = 1.0A			1.2	V
V _f	Internal Diode Forward Voltage Drop	I _F = 2A			2.5	V

* Pulse Test: PW ≤ 300μs, Duty Cycle ≤ 2%

Thermal Characteristics

Symbol	Parameter	Max.	Units
R _{θJC}	Thermal Resistance, Junction to Case	1.78	°C/W
R _{θJA}	Thermal Resistance, Junction to Ambient	62.5	°C/W

Typical Performance Characteristics

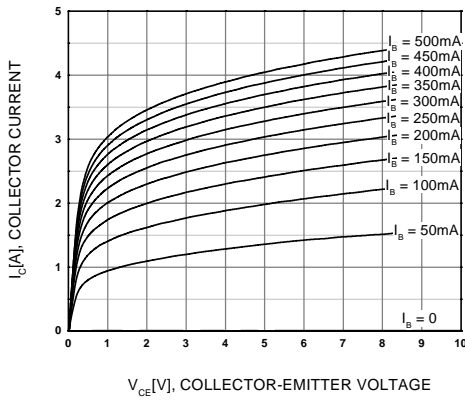

Figure 1. Static Characteristic

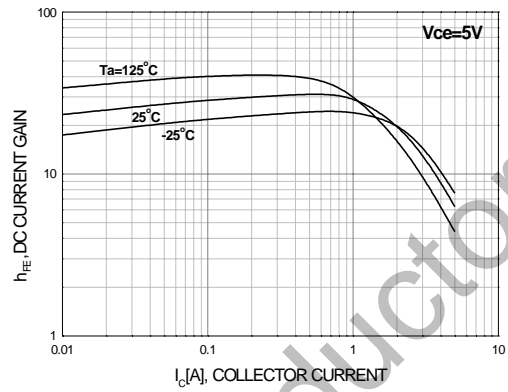

Figure 2. DC Current Gain

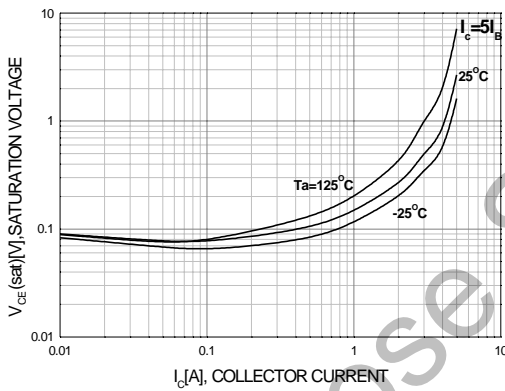

Figure 3. Collector-Emitter Saturation Voltage

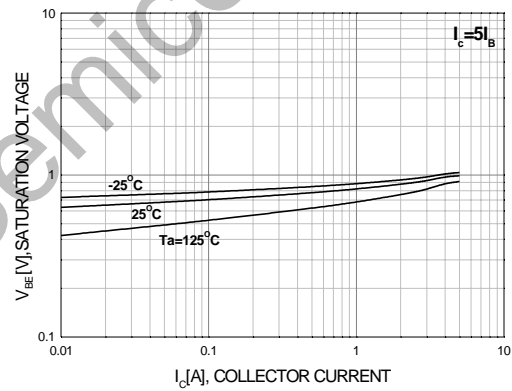

Figure 4. Base-Emitter Saturation Voltage

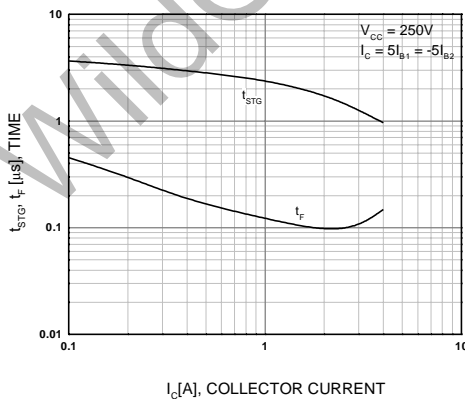

Figure 5. Resistive Load Switching Time

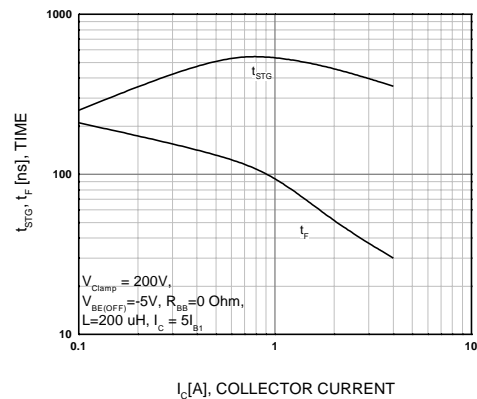

Figure 6. Inductive Load Switching Time

Typical Performance Characteristics

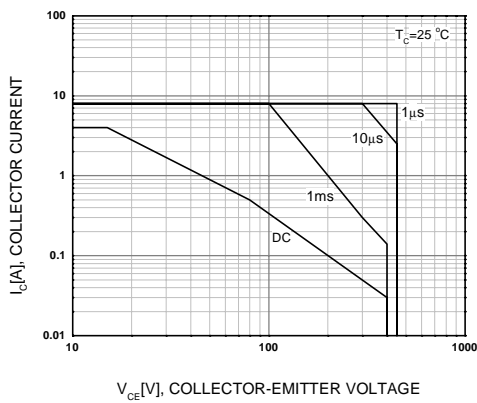

Figure 7. Forward Bias Safe Operating Area

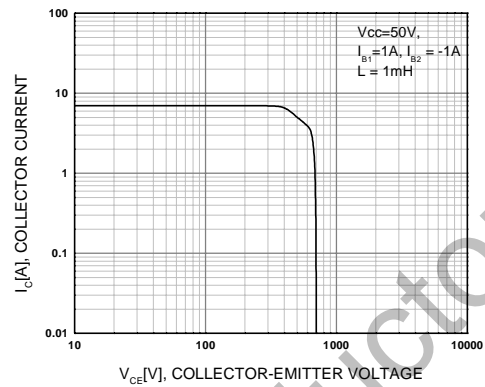

Figure 8. Reverse Bias Safe Operating Area

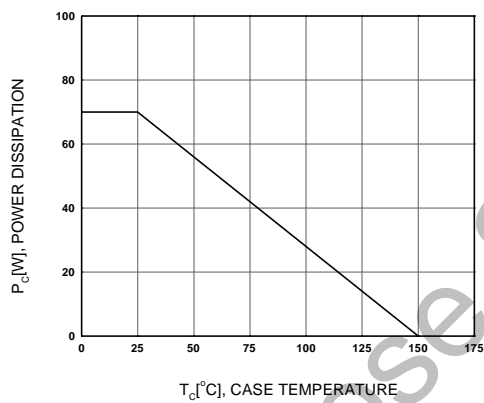
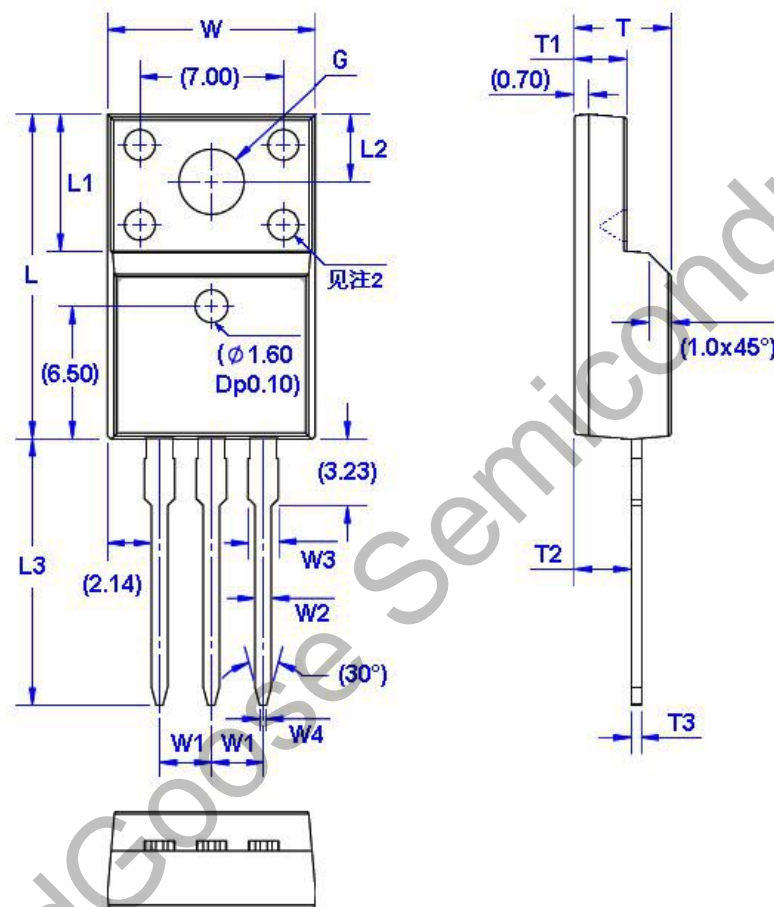

Figure 9. Power Derating

Package Dimension

TO-220F

Unit: mm



Symbol	Size		Symbol	Size		Symbol	Size		Symbol	Size	
	Min	Max		Min	Max		Min	Max		Min	Max
W	9.96	10.36	W4	0.25	0.45	L3	12.78	13.18	T3	0.45	0.60
W1	2.54 (TYP)		L	15.67	16.07	T	4.50	4.90	G(Φ)	3.08	3.28
W2	0.70	0.90	L1	6.48	6.88	T1	2.34	2.74			
W3	1.24	1.47	L2	3.20	3.40	T2	2.56	2.96			