



### ■ Features

- Bi-directional ESD protection of two lines
- 450Watts peak pulse power (tp = 8/20μs)
- Working voltage: 5V
- Ultra low leakage: nA level
- Low clamping voltage
- IEC 61000-4-2 ±30kV contact ±30kV air
- IEC61000-4-4 (EFT) 80A (5/50ns)
- IEC 61000-4-5 (Lightning) 30A (8/20μs)

### ■ Applications

- Cellular Handsets and Accessories
- Notebooks and Handhelds
- Portable Instrumentation
- Set Top Box
- Industrial Controls
- Server and Desktop PC

### ■ Mechanical Data

- Package:SOT-23
- Molding compound flammability rating: UL 94V-0
- RoHS/WEEE Compliant

### ■ Schematic & PIN Configuration

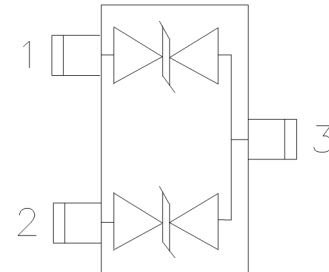

### ■ Ordering Information

Part Number	Package	Marking	Packing	Reel Size
PESD5V0L2BT	SOT-23	<p>M05C</p>	3000 Tape & Reel	7 inches

■ Absolute Maximum Rating( $T_A=25^{\circ}\text{C}$  unless otherwise Specified)

Parameter	Symbol	Value	Unit
Peak Pulse Power (8/20 $\mu\text{s}$ )	Ppk	450	W
Peak Pulse Current (8/20 $\mu\text{s}$ )	IPP	30	A
ESD per IEC 61000-4-2 (Air) ESD per IEC 61000-4-2 (Contact)	VESD	$\pm 30$ $\pm 30$	kV
Operating Temperature Range	TJ	-55 to +125	$^{\circ}\text{C}$
Storage Temperature Range	Tstg	-55 to +150	$^{\circ}\text{C}$

■ Electrical Characteristics( $T_A=25^{\circ}\text{C}$  unless otherwise Specified)

Parameter	Symbol	Test Condition	Min	Typ	Max	Unit
Reverse Working Voltage	VRWM				5.0	V
Breakdown Voltage	VBR	$I_T = 1\text{mA}$	6.0			V
Reverse Leakage Current	IR	VRWM = 5.0V			1.0	$\mu\text{A}$
Clamping Voltage	VC	IPP = 1A (8 x 20 $\mu\text{s}$ pulse)			8.0	V
Clamping Voltage	VC	IPP = 30A (8 x 20 $\mu\text{s}$ pulse)		12.5	15.0	V
Junction Capacitance	CJ	VR = 0V, f = 1MHz, IO-GND		60	100	pF

■ Electrical Parameters ( $T_A = 25^{\circ}\text{C}$  unless otherwise noted)

Symbol	Parameter
$I_T$	Test Current
IPP	Maximum Reverse Peak Pulse Current
Vc	Clamping Voltage @Ic

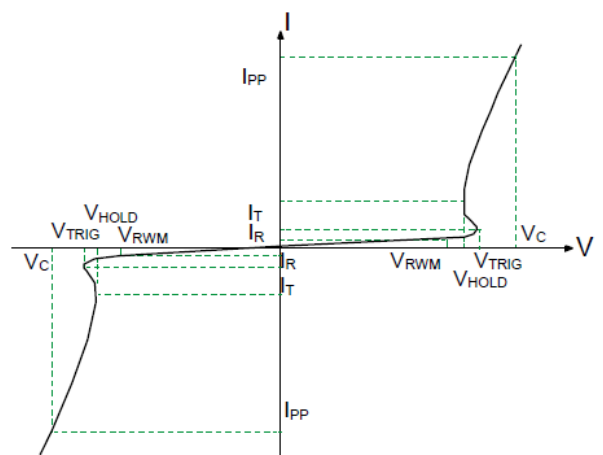



■ Typical Characteristics( $T_A=25^{\circ}\text{C}$  unless otherwise Specified)

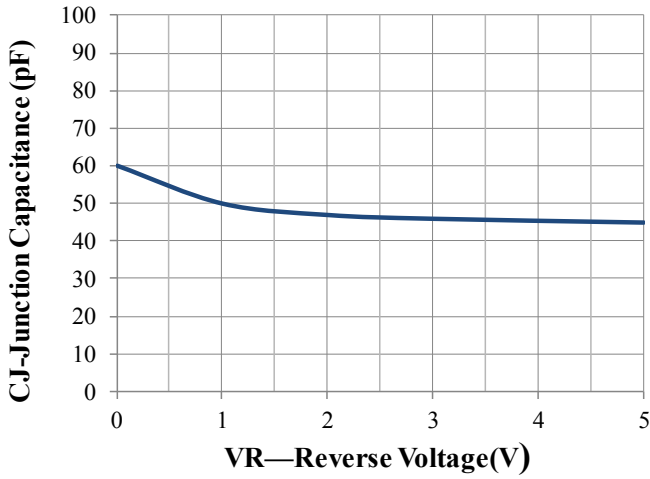

Junction Capacitance vs. Reverse Voltage

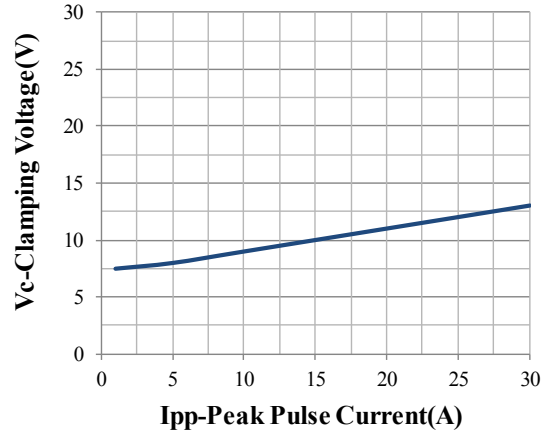

Clamping Voltage vs. Peak Pulse Current

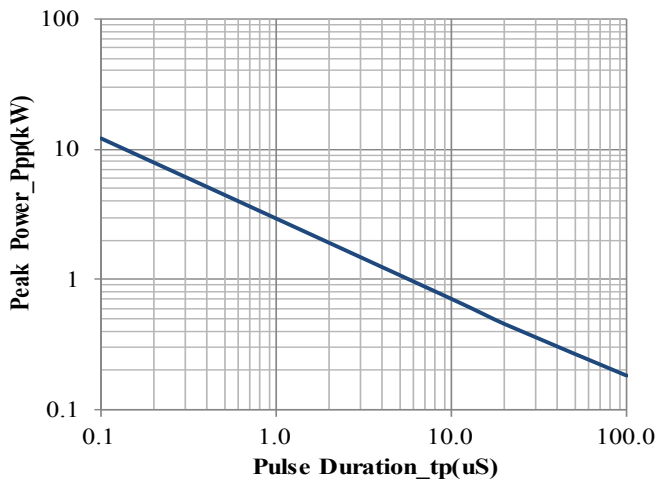

Peak Pulse Power vs. Pulse Time

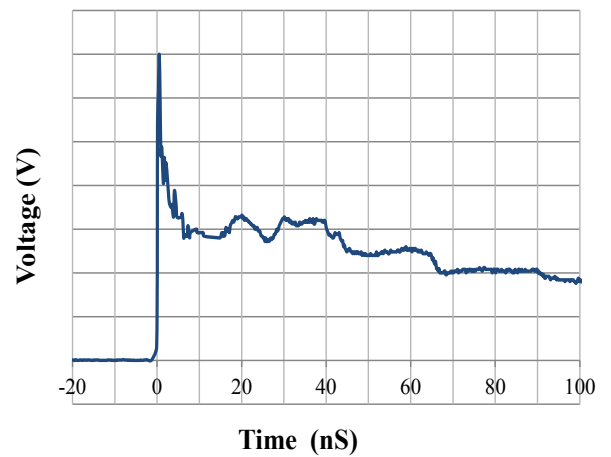

IEC61000-4-2 Pulse Waveform

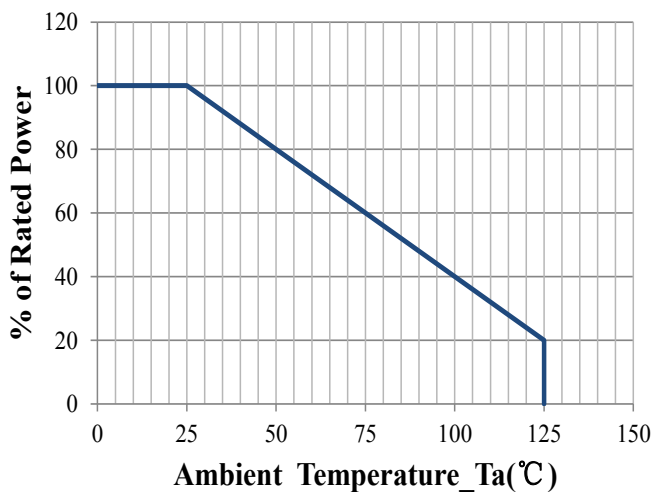

Power Derating Curve

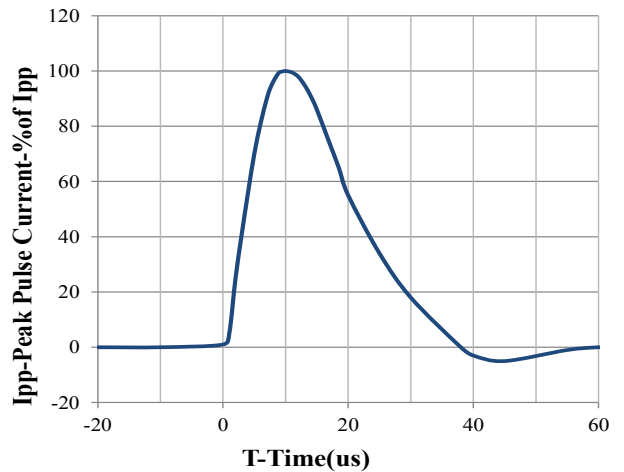

8 X 20us Pulse Waveform



■ Outline Drawing – SOT-23

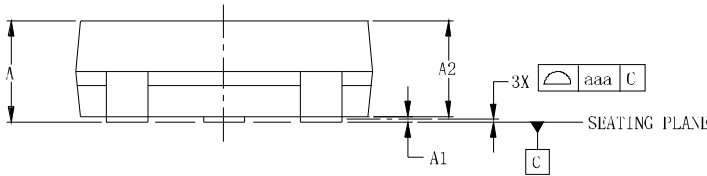
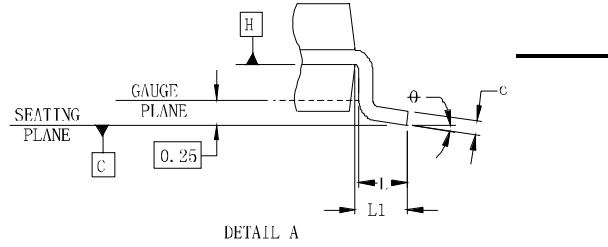
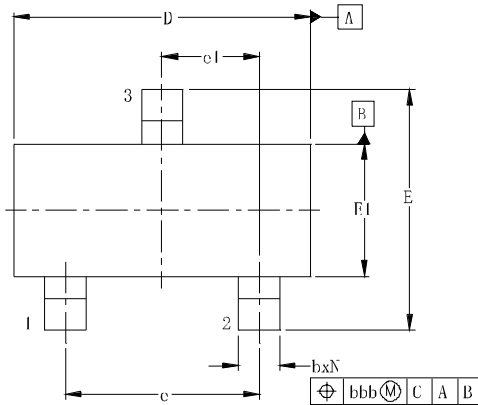

DIM	DIMENSIONS					
	INCHES			MILLIMETERS		
	MTN	NOM	MAX	MTN	NOM	MAX
A	.035	—	.044	0.89	—	1.12
A1	.000	—	.004	0.01	—	0.10
A2	.035	.037	.040	0.88	0.95	1.02
b	.012	—	.020	0.30	—	0.51
c	.003	—	.007	0.08	—	0.18
D	.110	.114	.120	2.80	2.90	3.04
E	.082	.093	.104	2.10	2.37	2.64
E1	.047	.051	.055	1.20	1.30	1.40
e	.075			1.90 BSC		
e1	.037			0.95 BSC		
L	.015	.020	.024	0.40	0.50	0.60
L1	.022			(0.55)		
N	3			3		
θ	0°	—	8°	0°	—	8°
aaa	.001			0.10		
bbb	.008			0.20		