

REVISION RECORD			
REV.	CONTENT	MOD.	DATE

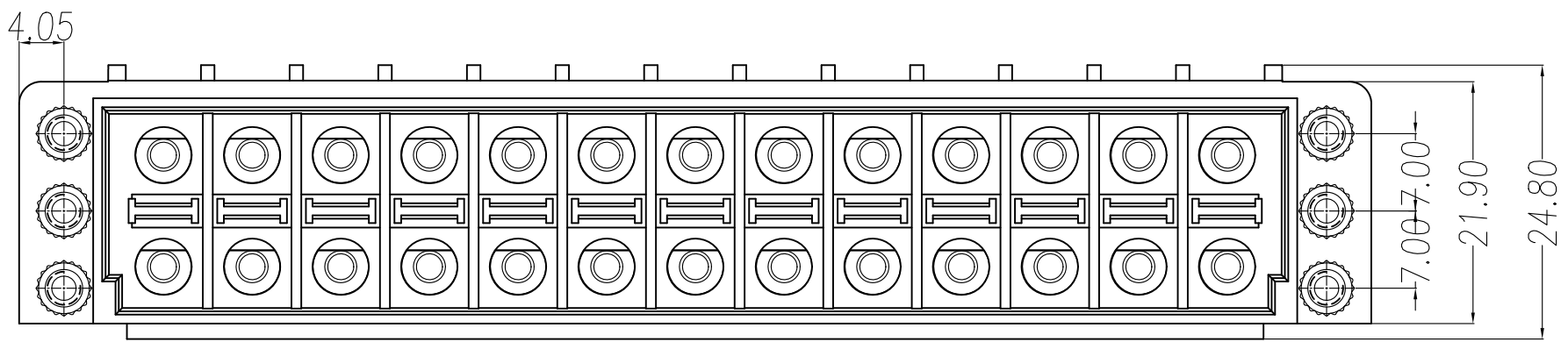
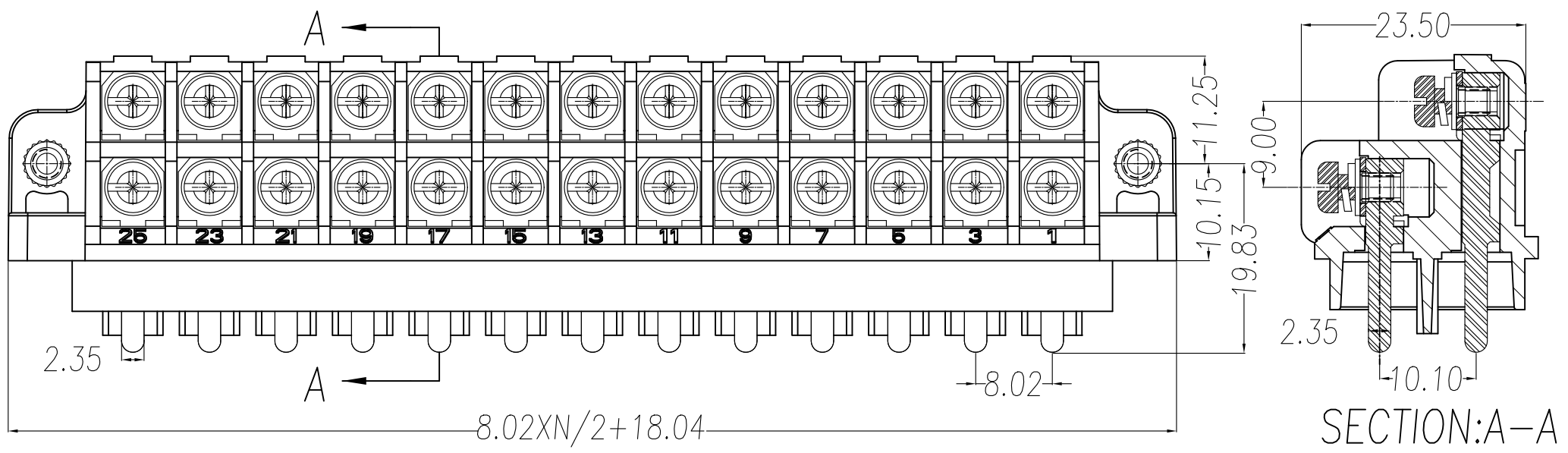

TOLERANCES EXCEPT AS NOTED

variable range	linear dimension					fillet	chamfer	∠ short angle sid			≡	—	□	//	⊥		
	to 6	over 6 to 30	over 30 to 120	over 120 to 480	over 480 to			to 6	to 10	to 30'						to 50'	to 10'
tolerance	±0.1	±0.2	±0.3	±0.5	±0.9	±0.2	±0.5	±1	1'	30'	20'	10'	0.5	0.025	0.06	0.12	0.4

NO.	NAME OF PART	NO. OF PART	Q'TY	MATERIAL	NOTES
DES.	jackchen	DATE 2014. 12. 29	UNITS mm	Third ANGLE PROJECTION	SHEET 1 of 1
CHK.	DATE	SIZE A4	SCALE 2:1	DWG NO.	
APP.	DATE	SCALE 2:1	DWG NO.		
拓宜(上海)工控电器设备有限公司 Topone (Shanghai) Industrial Control Electrical Equipment Co., LTD.				TITLE	TYCS12D-26-ZM TYCS12D