

## Features

- Transient protection for high-speed data lines  
IEC61000 -4-2 (ESD)  $\pm 20\text{kV}$  (Air)  
 $\pm 20\text{kV}$  (Contact)  
IEC 61000-4-5 (Lightning) 4.0A (8/20 $\mu\text{s}$ )
- Cable Discharge Event (CDE)
- Array of surge rated diodes with internal TVS diode
- Small package saves board space
- Protects four I/O lines
- Low capacitance: 0.5pF@0V(Typical)(I/O-GND)  
0.25pF@0V(Typical)(I/O-I/O)
- Low leakage current: 0.1 $\mu\text{A}$  @ VRWM (Typical)
- Low clamping voltage
- Each I/O pin can withstand over 1000 ESD strikes for  $\pm 8\text{kV}$  contact discharge

## Description

TT0514SPX is an ultra-low capacitance Transient Voltage Suppressor (TVS) designed to provide electrostatic discharge (ESD) protection for high-speed data interfaces. With typical capacitance of 0.5pF only, is designed to protect parasitic-sensitive systems against over-voltage and over-current transient events. It complies with IEC61000-4-2 (ESD), Level 4 ( $\pm 15\text{kV}$  air,  $\pm 8\text{kV}$  contact discharge), IEC61000-4-4 (electrical fast transient-EFT)(40A, 5/50ns), very fast charged device model (CDM) ESD and cable discharge event (CDE), etc.

The TT0514SPX comes in a RoHS compliant and Halogen Free 2.5mm x 1.0mm x 0.55mm DFN2510-10L package. This device incorporates eight surge rated, ultra-low capacitance steering diodes and a TVS in a single package. During transient conditions, the steering diodes direct the transient to either the positive side of the power supply line or to ground.

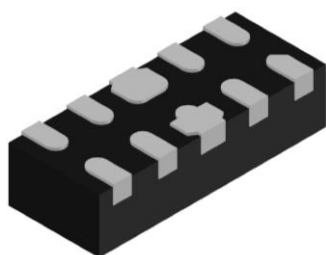

DFN2510-10L  
(Bottom View)

## Applications

- HDMI 1.4/2.0, USB 3.0/3.1, MDDI, SATA ports
- Monitors and flat panel displays
- Set-top box
- Video graphics cards
- Digital Video Interface (DVI)
- Notebook computers

## Mechanical Characteristics

- Package: DFN2510-10L
- Marking: Part number
- Packaging: Tape and Reel
- ROHS compliant

## Circuit Diagram

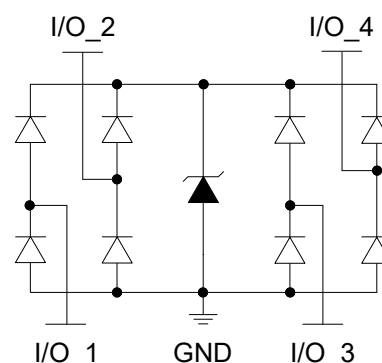

## Pin Configuration

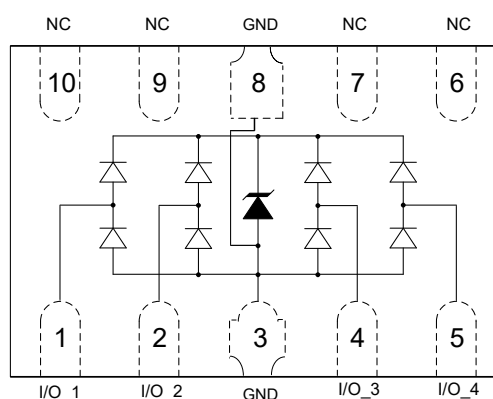

DFN2510-10L  
(Top View)

## Absolute Maximum Rating

Symbol	Parameter	Value	Units
$I_{PP}$	Peak Pulse Current (8/20 $\mu$ s)	4	A
$P_{PK}$	Peak Pulse Power (8/20 $\mu$ s)	40	W
$V_{ESD}$	ESD per IEC61000-4-2 (Air) ESD per IEC61000-4-2 (Contact)	$\pm 20$ $\pm 20$	kV
$T_{OPT}$	Operating Temperature	-55/+125	$^{\circ}$ C
$T_{STG}$	Storage Temperature	-55/+150	$^{\circ}$ C

## Electrical Characteristics (T = 25 $^{\circ}$ C)

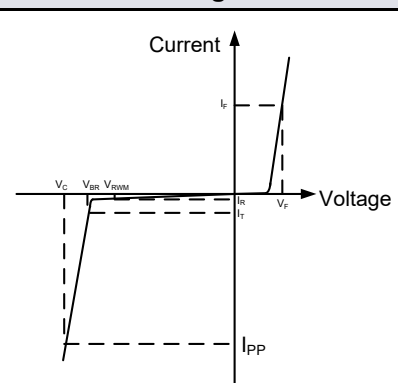
Symbol	Parameter	Diagram
$V_{RWM}$	Nominal Reverse Working Voltage	
$I_R$	Reverse Leakage Current @ $V_{RWM}$	
$V_{BR}$	Reverse Breakdown Voltage @ $I_T$	
$I_T$	Test Current for Reverse Breakdown	
$V_C$	Clamping Voltage @ $I_{PP}$	
$I_{PP}$	Maximum Peak Pulse Current	
$C_{ESD}$	Parasitic Capacitance	
$I_F$	Forward Current	
$V_F$	Forward Voltage @ $I_F$	

Symbol	Test Condition	Minimum	Typical	Maximum	Units
$V_{RWM}$				5.0	V
$I_R$	$V_{RWM} = 5V, T = 25^{\circ}C$ Between I/O and GND		0.1	1.0	$\mu$ A
$V_{BR}$	$I_T = 1mA$ Between I/O and GND	6.0	8.0	10.0	V
$V_C$	$I_{PP} = 4A, t_p = 8/20\mu s$ Between I/O and GND		10.0		V
$V_C$	$I_{PP} = 8.0A, t_p = 100ns^{(1)}$		10.7		V
	$I_{PP} = 16.0A, t_p = 100ns^{(1)}$		13.2		V
$R_{dyn}$	$I_{PP} = 12.0A, t_p = 100ns^{(1)}$		0.3		$\Omega$
$C_{ESD}$	$V_R = 0V, f = 1MHz$ Between I/O and GND		0.5		pF
$C_{ESD}$	$V_R = 0V, f = 1MHz$ Between I/O and I/O		0.25		pF

Notes:(1)Measurements performed using a 100ns Transmission Line Pulse(TLP) system,Between I/O and GND.

## Typical Performance Characteristics

**TLP Measurement of I/O to GND**

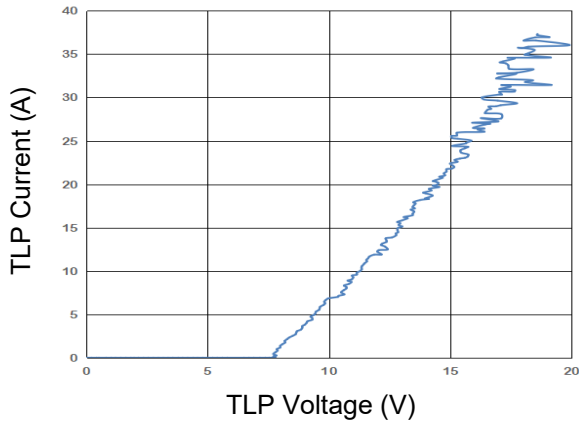

**TLP Measurement of I/O to I/O**

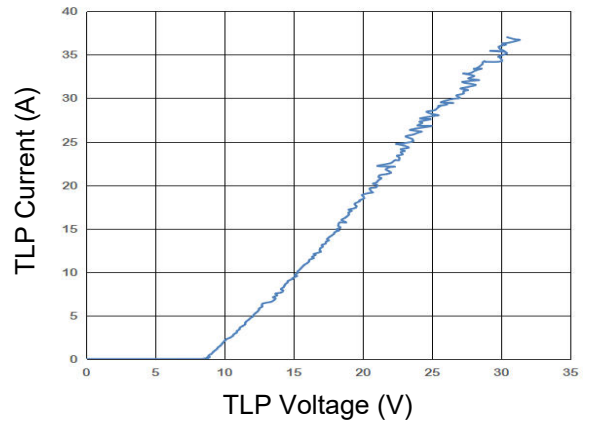

**Capacitance vs Reverse Voltage IO to GND**

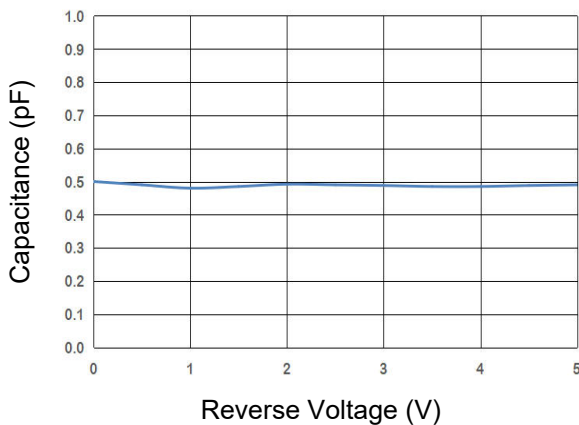

**Capacitance vs Reverse Voltage IO to IO**

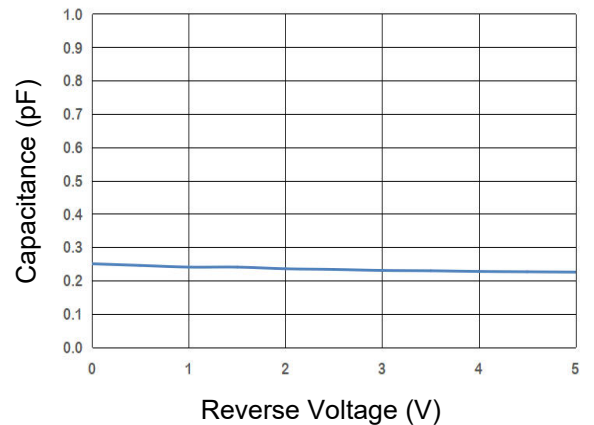

**8/20us Current IO to GND**

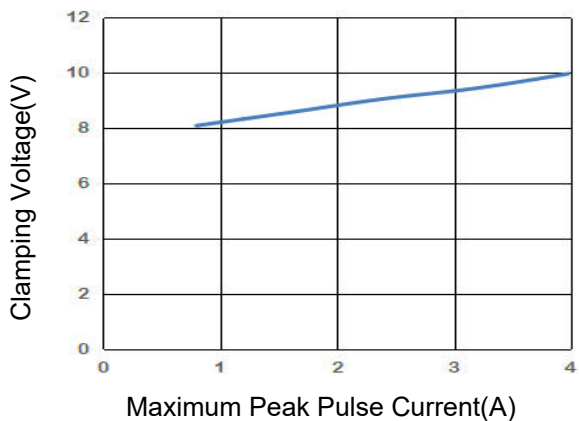

## Recommended Soldering Conditions

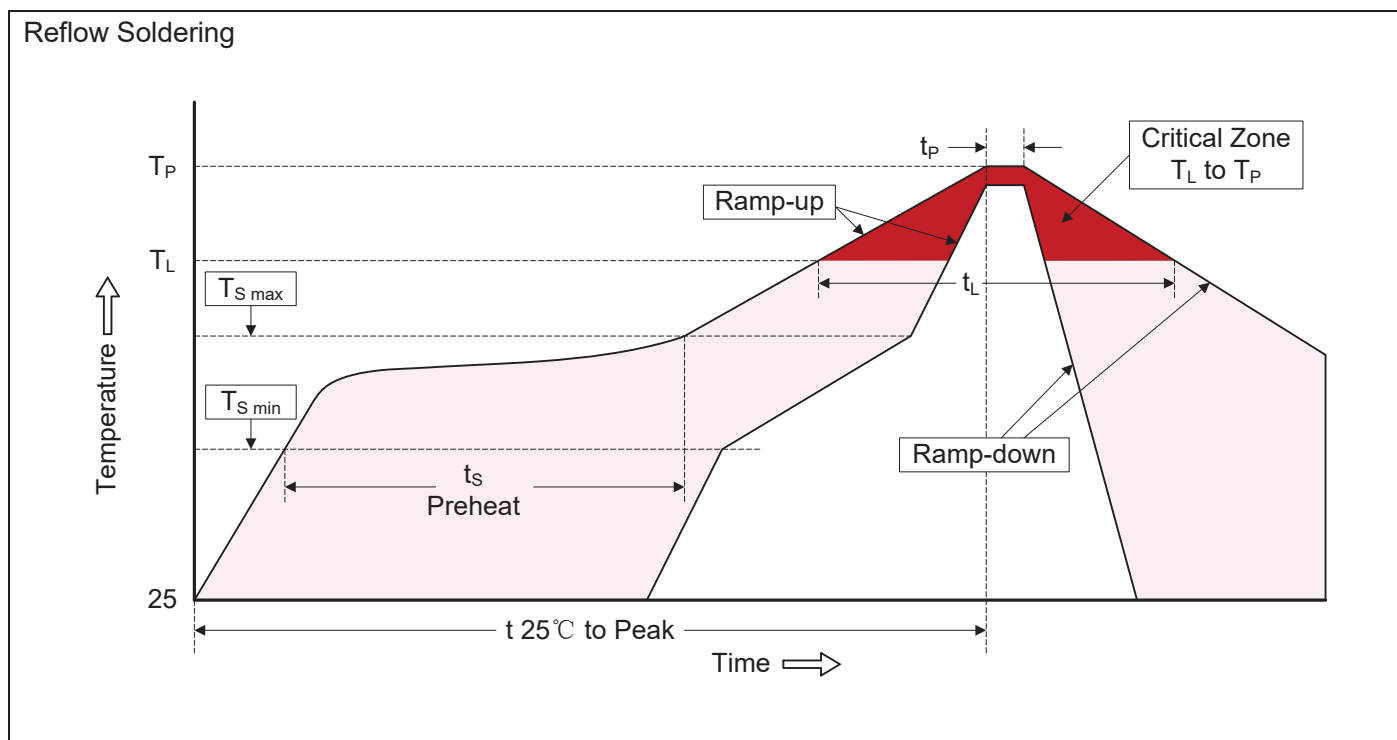

### Recommended Conditions

Profile Feature	Pb-Free Assembly
Average ramp-up rate ( $T_L$ to $T_P$ )	3°C/second max.
Preheat -Temperature Min ( $T_{S\ min}$ ) -Temperature Max ( $T_{S\ max}$ ) -Time (min to max) ( $t_s$ )	150°C 200°C 60-180 seconds
$T_{S\ max}$ to $T_L$ -Ramp-up Rate	3°C/second max.
Time maintained above: -Temperature ( $T_L$ ) -Time ( $t_L$ )	217°C 60-150 seconds
Peak Temperature ( $T_P$ )	260°C
Time within 5°C of actual Peak Temperature ( $t_p$ )	20-40 seconds
Ramp-down Rate	6°C/second max.
Time 25°C to Peak Temperature	8 minutes max.

## High Speed PCB Layout Guidelines

Printed circuit board layout is the key to achieving the highest level of surge immunity on power and data lines. The location of the protection devices on the PCB is the simplest and most important design rule to follow. The TT0514SPX devices should be located as close as possible to the noise source. The TT0514SPX device should be placed on all data and power lines that enter or exit the PCB at the I/O connector. In most systems, surge pulses occur on data and power lines that enter the PCB through the I/O connector. Placing the TT0514SPX devices as close as possible to the noise source ensures that a surge voltage will be clamped before the pulse can be coupled into adjacent PCB traces. In addition, the PCB should use the shortest possible traces. A short trace length equates to low impedance, which ensures that the surge energy will be dissipated by the TT0514SPX device. Long signal traces will act as antennas to receive energy from fields that are produced by the ESD pulse. By keeping line lengths as short as possible, the efficiency of the line to act as an antenna for ESD related fields is reduced. Minimize interconnecting line lengths by placing devices with the most interconnect as close together as possible. The protection circuits should shunt the surge voltage to either the reference or chassis ground. Shunting the surge voltage directly to the IC's signal ground can cause ground bounce. The clamping performance of TVS diodes on a single ground PCB can be improved by minimizing the impedance with relatively short and wide ground traces. The PCB layout and IC package parasitic inductances can cause significant overshoot to the TVS's clamping voltage. The inductance of the PCB can be reduced by using short trace lengths and multiple layers with separate ground and power planes. One effective method to minimize loop problems is to incorporate a ground plane in the PCB design.

The TT0514SPX ultra-low capacitance TVS is designed to protect four high speed data transmission lines from transient over-voltages by clamping them to a fixed reference. The low inductance and construction minimizes voltage overshoot during high current surges. When the voltage on the protected line exceeds the reference voltage the internal steering diodes are forward biased, conducting the transient current away from the sensitive circuitry. The TT0514SPX is designed for ease of PCB layout by allowing the traces to run underneath the device. The pinout of the TT0514SPX is designed to simply drop onto the IO lines of a High Definition Multimedia Interface (HDMI 1.4/2.0) or USB 3.0/3.1 design without having to divert the signal lines that may add more parasitic inductance. Pins 1, 2, 4 and 5 are connected to the internal TVS devices and pins 6, 7, 9 and 10 are no connects. The no connects was done so the package can be securely soldered onto the PCB surface.

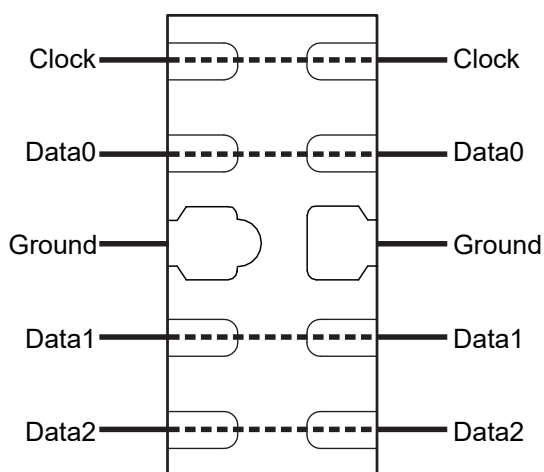

**Flow Through Layout for HDMI 1.4/2.0**

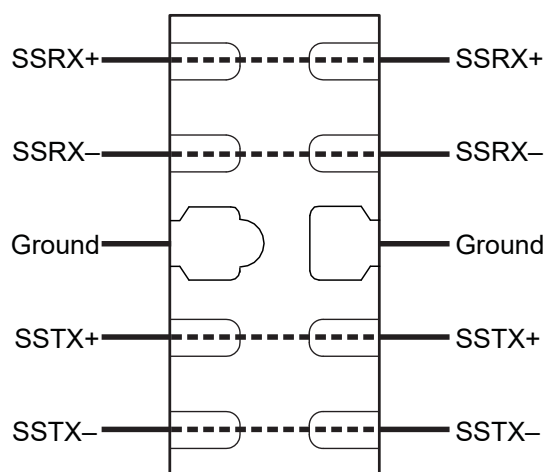

**Flow Through Layout for USB 3.0/3.1**

## Application Information

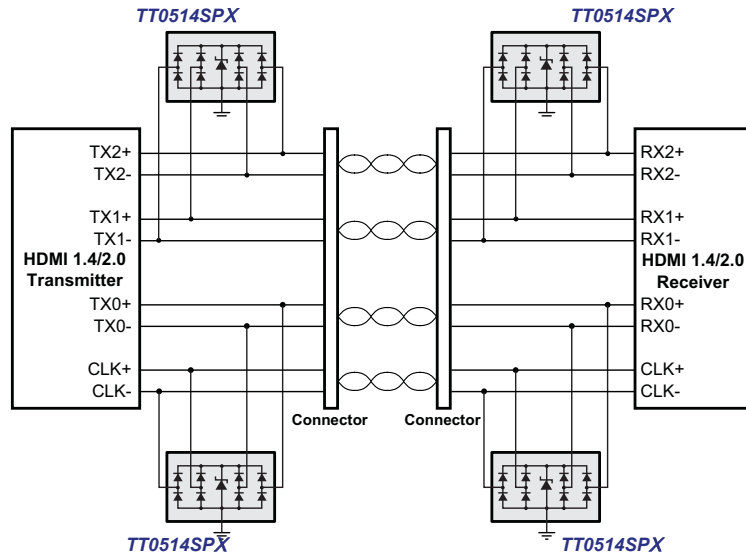

**HDMI 1.4/2.0 Ports**

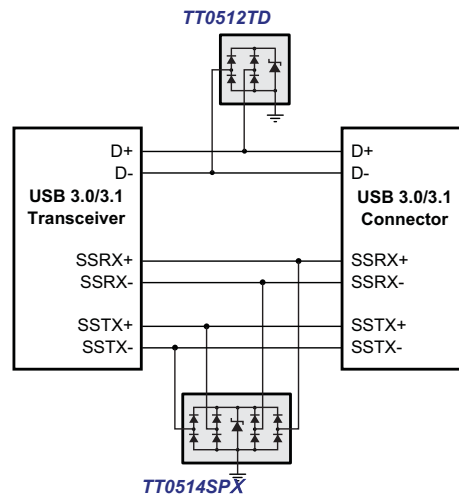

**USB 3.0/3.1 Ports**

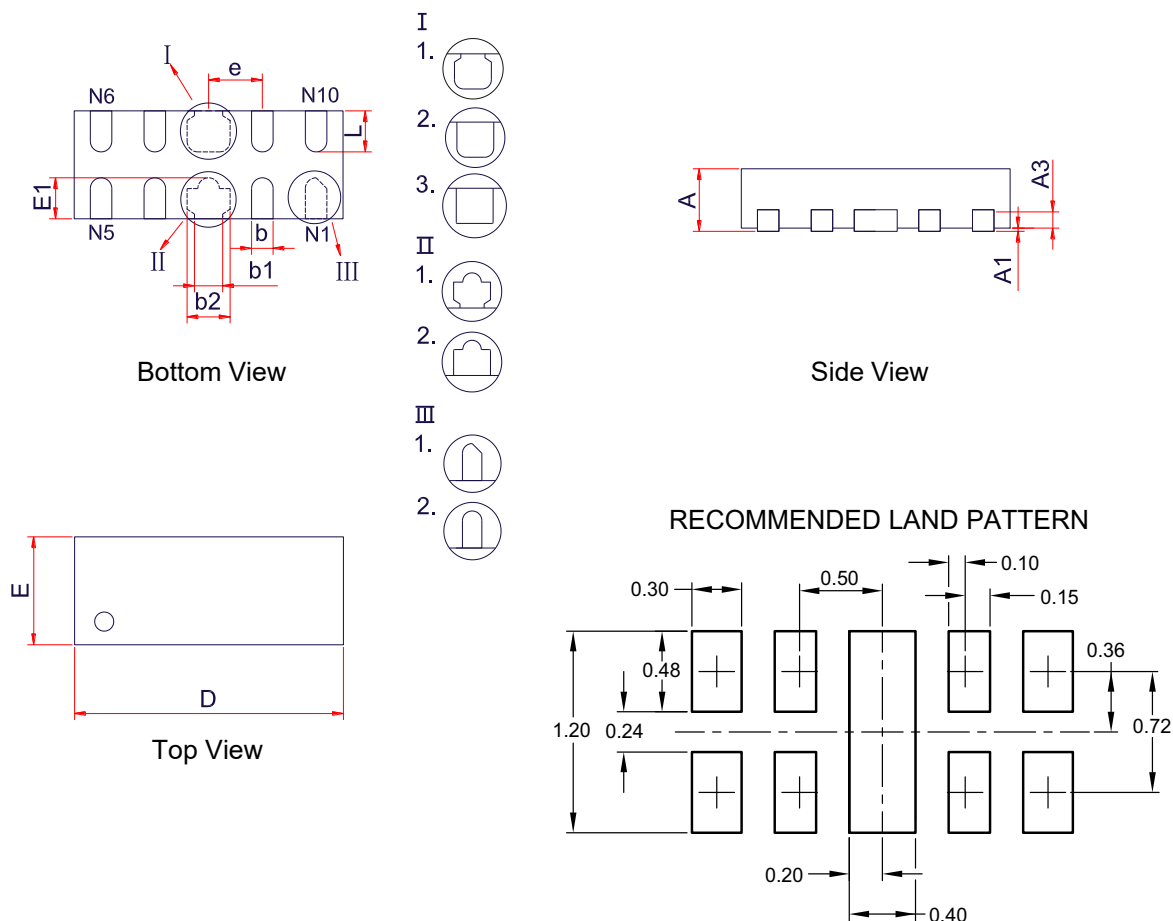
**Package Outline, DFN2510-10L**

Symbol	Dimensions in Millimeters		
	Min.	Typ.	Max.
A	0.45	0.52	0.60
A1	0.00	0.02	0.05
A3	0.15Ref		
D	2.40	2.50	2.60
E	0.90	1.00	1.10
E1	0.50Ref		
b	0.15	0.20	0.25
b1	0.13	0.18	0.23
b2	0.35	0.40	0.45
e	0.50BSC		
L	0.28	0.39	0.50

## Tape and Reel Specification

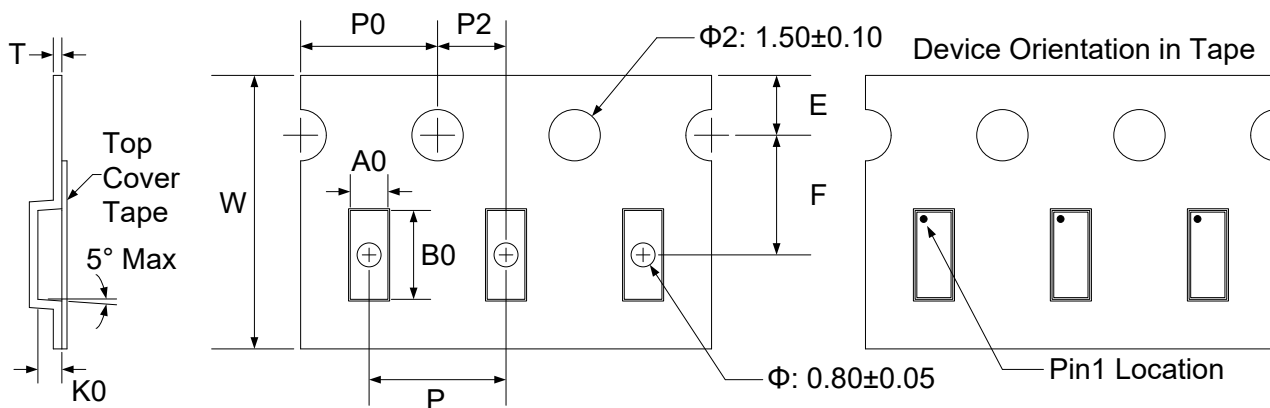

Symbol	W	A0	B0	K0	E	F	P	P0	P2	T
Dimensions (mm)	8.00+0.3 -0.1	1.23±0.05	2.7±0.05	0.7±0.05	1.75±0.1	3.5±0.05	4.0±0.1	4.0±0.1	2.0±0.05	0.25±0.02

## Marking Codes

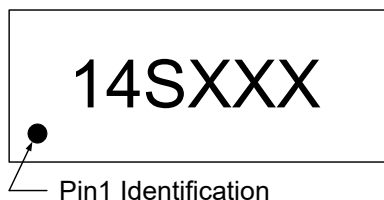

### Note:

- (1) "14S" is part number, fixed.
- (2) "XXX" is the identification number.

## Ordering Information

Part Number	Working Voltage	Quantity Per Reel	Reel Size
TT0514SPX	5V	3,000	7 Inch