

Features

- Transient protection for high-speed data lines
IEC61000-4-2 (ESD) $\pm 25\text{kV}$ (Air)
 $\pm 25\text{kV}$ (Contact)
IEC61000-4-5 (Lightning) 4.0A (8/20 μs)
- Small package saves board space
- Protects four I/O lines
- Low capacitance: 0.3pF (Typical)
- Low leakage current: 0.01 μA @ V_{RWM} (Maximum)
- Low clamping voltage

Description

TT0504SPX is an ultra-low capacitance Transient Voltage Suppressor (TVS) designed to provide electrostatic discharge (ESD) protection for high-speed data interfaces. With typical capacitance of 0.3pF only, it is designed to protect parasitic-sensitive systems against over-voltage and over-current transient events.

The TT0504SPX comes in a ROHS compliant and Halogen Free 2.5mm x 1.0mm x 0.55mm DFN2510-10L package.

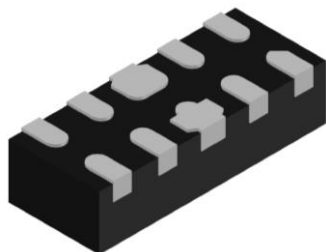

DFN2510-10L
(Bottom View)

Applications

- Portable applications
- Communication systems
- Computers and peripherals
- High speed data lines:
 - USB 2.0/3.1 (Gen 1)
 - HDMI 1.3/1.4/2.0
 - eSATA
 - DisplayPort

Mechanical Characteristics

- Package: DFN2510-10L
- Marking: Part number
- Packaging: Tape and Reel
- ROHS compliant
- Moisture Sensitivity Level (MSL Level-1)

Circuit Diagram

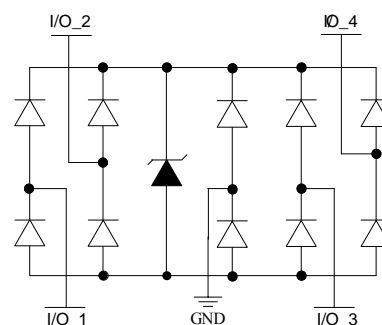

Pin Configuration

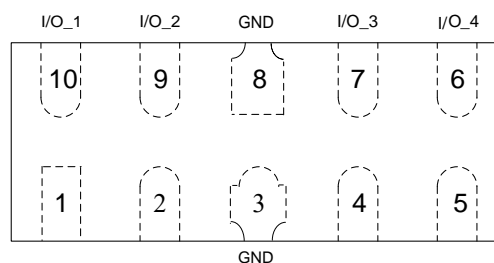

DFN2510-10L
(Top View)

Absolute Maximum Rating

Symbol	Parameter	Value	Units
I_{PP}	Peak Pulse Current (8/20 μ s)	4	A
V_{ESD}	ESD per IEC61000-4-2 (Air) ESD per IEC61000-4-2 (Contact)	± 25 ± 25	kV
T_{OPT}	Operating Temperature	-55/+125	°C
T_{STG}	Storage Temperature	-55/+150	°C

Electrical Characteristics (T = 25°C)

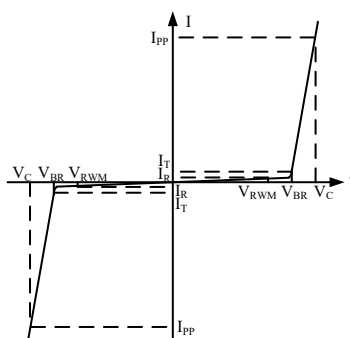
Symbol	Parameter	Diagram
V_{RWM}	Nominal Reverse Working Voltage	
I_R	Reverse Leakage Current @ V_{RWM}	
V_{BR}	Reverse Breakdown Voltage @ I_T	
I_T	Test Current for Reverse Breakdown	
V_C	Clamping Voltage @ I_{PP}	
I_{PP}	Maximum Peak Pulse Current	
C_{ESD}	Parasitic Capacitance	

Symbol	Test Condition	Minimum	Typical	Maximum	Units
V_{RWM}				5.0	V
I_R	$V_{RWM} = 5.0V$, T = 25°C Between I/O and GND		0.1	1.0	μ A
V_{BR}	$I_T = 1mA$ Between I/O and GND	6.0			V
V_C	$I_{PP} = 1A$, $t_p = 8/20\mu s$ Between I/O and GND		8.6		V
V_C	$I_{PP} = 4A$, $t_p = 8/20\mu s$ Between I/O and GND		12.5		V
V_C	$I_{PP} = 8.0A$, $t_p = 100ns^{(1)}$		12.8		V
	$I_{PP} = 16.0A$, $t_p = 100ns^{(1)}$		16.4		V
R_{dyn}	$I_{PP} = 12.0A$, $t_p = 100ns^{(1)}$		0.45		Ω
C_{ESD}	$V_R = 0V$, f = 1MHz Between I/O and I/O		0.2	0.3	pF
C_{ESD}	$V_R = 0V$, f = 1MHz Between I/O and GND		0.3	0.45	pF

Notes:(1)Measurements performed using a 100ns Transmission Line Pulse(TLP) system,Between I/O and GND.

Typical Performance Characteristics

TLP Measurement of I/O to GND

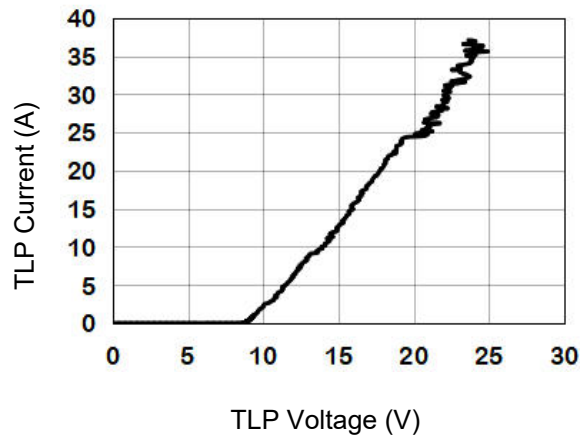

8/20us Current I/O to GND

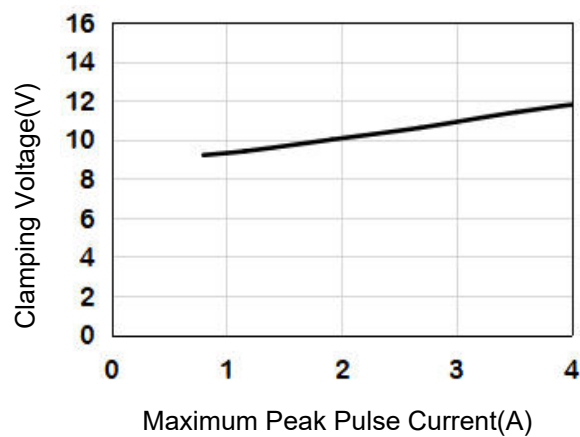

Recommended Soldering Conditions

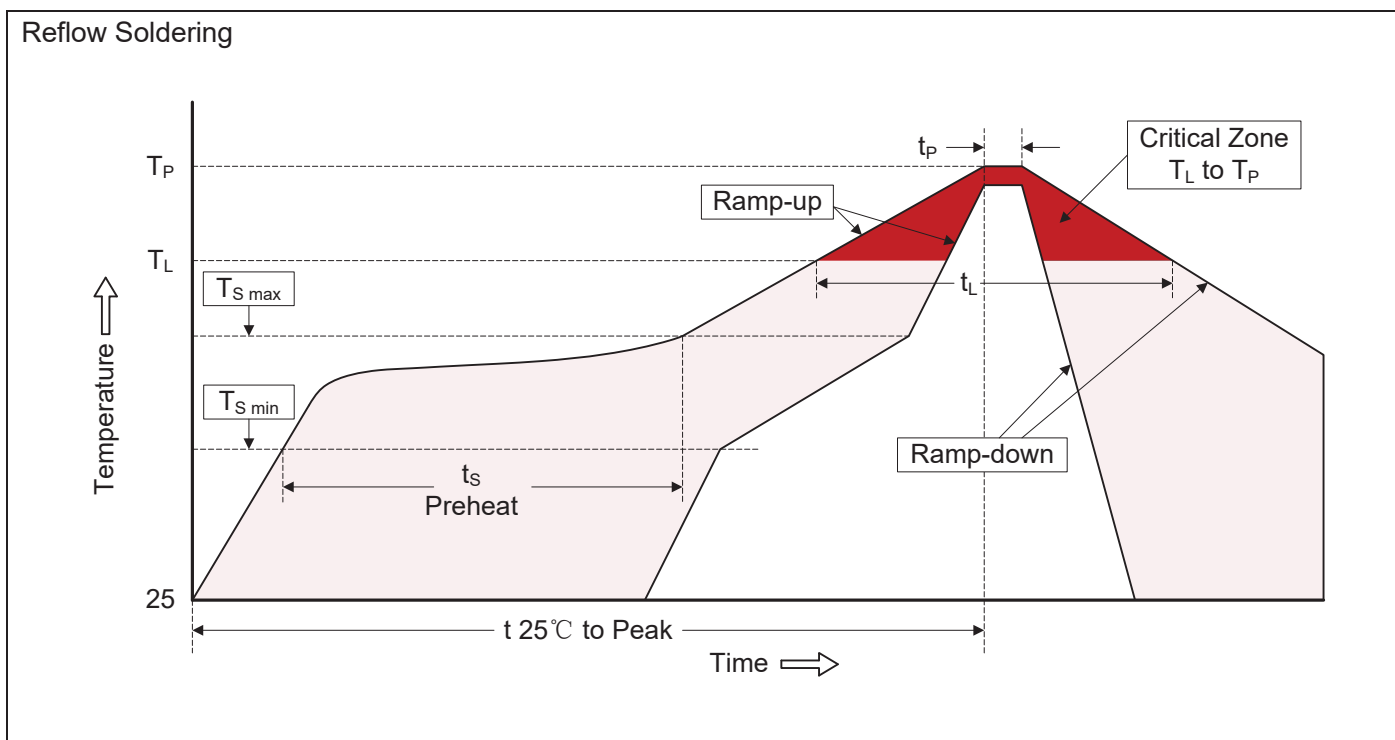

Recommended Conditions

Profile Feature	Pb-Free Assembly
Average ramp-up rate (T_L to T_P)	3°C/second max.
Preheat -Temperature Min ($T_{S\ min}$) -Temperature Max ($T_{S\ max}$) -Time (min to max) (t_s)	150°C 200°C 60-180 seconds
$T_{S\ max}$ to T_L -Ramp-up Rate	3°C/second max.
Time maintained above: -Temperature (T_L) -Time (t_L)	217°C 60-150 seconds
Peak Temperature (T_P)	260°C
Time within 5°C of actual Peak Temperature (t_P)	20-40 seconds
Ramp-down Rate	6°C/second max.
Time 25°C to Peak Temperature	8 minutes max.

Package Outline, DFN2510-10L

- DFN2510-10L package

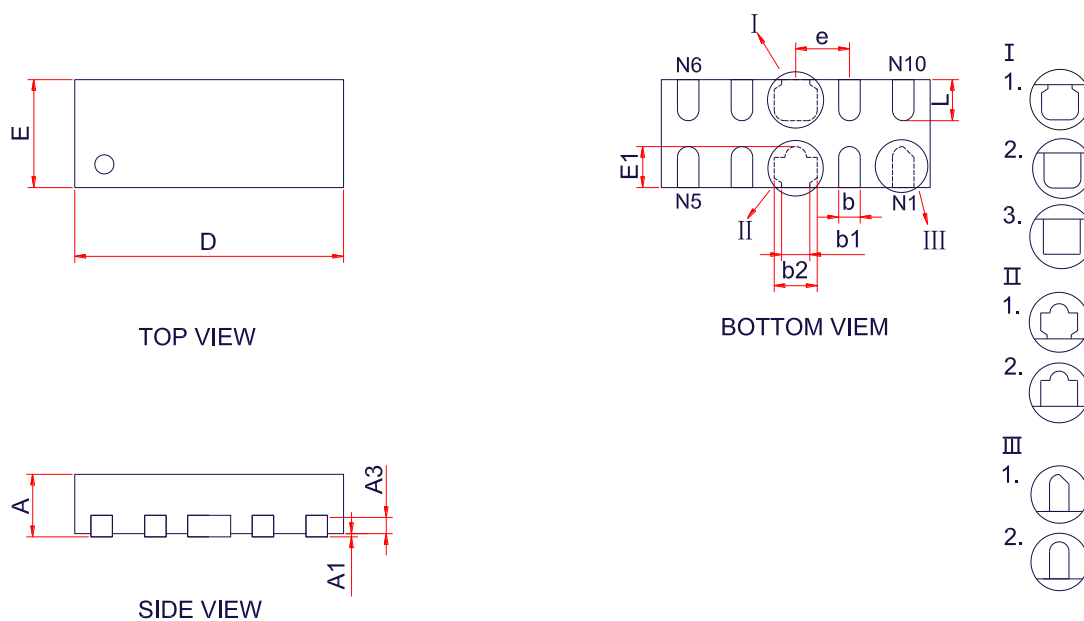

Symbol	Dimensions in Millimeters		
	Min.	Typ.	Max.
A	0.45	0.53	0.60
A1	0.00	0.02	0.05
A3	0.15Ref		
D	2.40	2.50	2.60
E	0.90	1.00	1.10
E1	0.50Ref		
b	0.15	0.20	0.25
b1	0.13	0.18	0.23
b2	0.35	0.40	0.45
e	0.50BSC		
L	0.28	0.39	0.50

Tape and Reel Specification

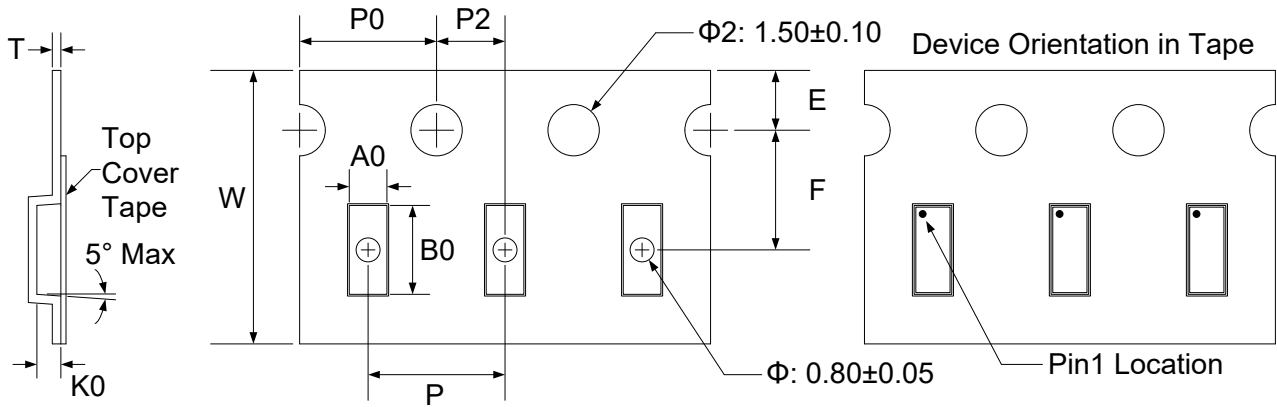

Symbol	W	A0	B0	K0	E	F	P	P0	P2	T
Dimensions (mm)	8.00+0.3 -0.1	1.23±0.05	2.7±0.05	0.7±0.05	1.75±0.1	3.5±0.05	4.0±0.1	4.0±0.1	2.0±0.05	0.25±0.02

Marking Codes

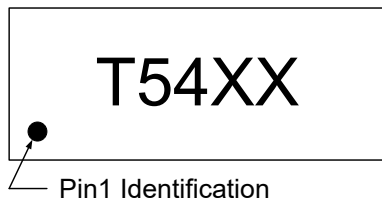

Note:

- (1) "T54" is part number, fixed.
- (2) "XX" is the identification number.

Ordering Information

Part Number	Working Voltage	Quantity Per Reel	Reel Size
TT0504SPX	5.0V	3,000	7 Inch