

Features

- Transient protection for high-speed data lines
 IEC61000-4-2 (ESD) $\pm 10\text{kV}$ (Air)
 $\pm 10\text{kV}$ (Contact)
 IEC61000-4-5 (Lightning) 3.0A (8/20 μs)
- Small package saves board space
- Protects four I/O lines
- Low capacitance: 0.38pF (Typical)
- Low leakage current: 0.01 μA @ V_{RWM} (Maximum)
- Low clamping voltage

Description

TT0214 SPX is an ultra -low capacitance Transient Voltage Suppressor (TVS) designed to provide electrostatic discharge (ESD) protection for high-speed data interfaces. With typical capacitance of 0.38pF only, it is designed to protect parasitic-sensitive systems against over-voltage and over-current transient events.

The TT0214 SPX comes in a ROHS compliant and Halogen Free 2.5mm x 1.0mm x 0.55mm DFN2510-10L package.

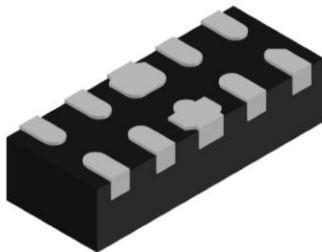

DFN2510-10L
(Bottom View)

Applications

- Portable applications
- Communication systems
- Computers and peripherals
- High speed data lines:
 - USB 2.0/3.1 (Gen 1)
 - HDMI 1.3/1.4
 - eSATA
 - DisplayPort

Mechanical Characteristics

- Package: DFN2510-10L
- Marking: Part number
- Packaging: Tape and Reel
- ROHS compliant
- Moisture Sensitivity Level (MSL Level-1)

Circuit Diagram

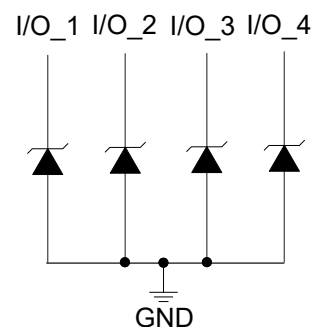

Pin Configuration

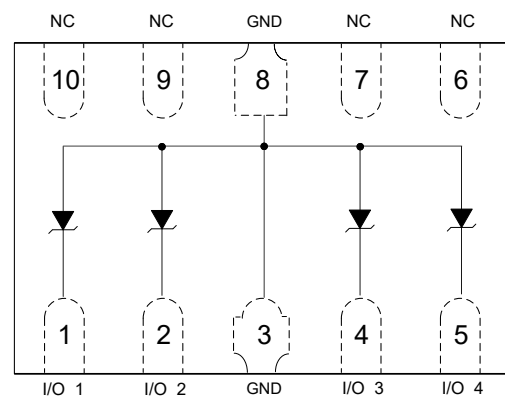

DFN2510-10L
(Top View)

Absolute Maximum Rating

Symbol	Parameter	Value	Units
I_{PP}	Peak Pulse Current (8/20 μ s)	3	A
V_{ESD}	ESD per IEC61000-4-2 (Air) ESD per IEC61000-4-2 (Contact)	± 10 ± 10	kV
T_{OPT}	Operating Temperature	-55/+125	°C
T_{STG}	Storage Temperature	-55/+150	°C

Electrical Characteristics (T = 25°C)

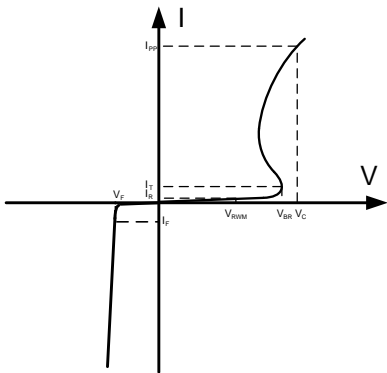
Symbol	Parameter	Diagram
V_{RWM}	Nominal Reverse Working Voltage	
I_R	Reverse Leakage Current @ V_{RWM}	
V_{BR}	Reverse Breakdown Voltage @ I_T	
I_T	Test Current for Reverse Breakdown	
V_C	Clamping Voltage @ I_{PP}	
I_{PP}	Maximum Peak Pulse Current	
C_{ESD}	Parasitic Capacitance	
I_F	Forward Current	
V_F	Forward Voltage @ I_F	

Symbol	Test Condition	Minimum	Typical	Maximum	Units
V_{RWM}				1.5	V
I_R	$V_{RWM} = 1.5V$, T = 25°C Between I/O and GND		1	10	nA
V_{BR}	$I_T = 1mA$ Between I/O and GND	2.5	3.3		V
V_C	$I_{PP} = 3A$, $t_p = 8/20\mu s$ Between I/O and GND		2.3		V
V_C	$I_{PP} = 8.0A$, $t_p = 100ns^{(1)}$		3.45		V
	$I_{PP} = 16.0A$, $t_p = 100ns^{(1)}$		5.70		V
R_{dyn}	$I_{PP} = 12.0A$, $t_p = 100ns^{(1)}$		0.28		Ω
C_{ESD}	$V_R = 1V$, f = 1MHz Between I/O and GND		0.38	0.45	pF

Notes:(1)Measurements performed using a 100ns Transmission Line Pulse(TLP) system,Between I/O and GND.

Typical Performance Characteristics

Capacitance vs Reverse Voltage I/O to GND

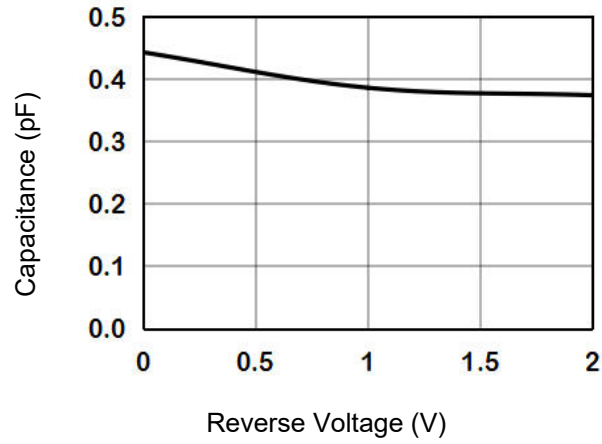

TLP Measurement of I/O to GND

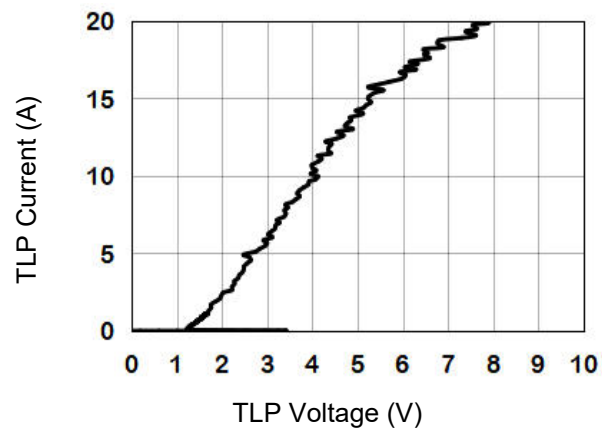

8/20us Current I/O to GND

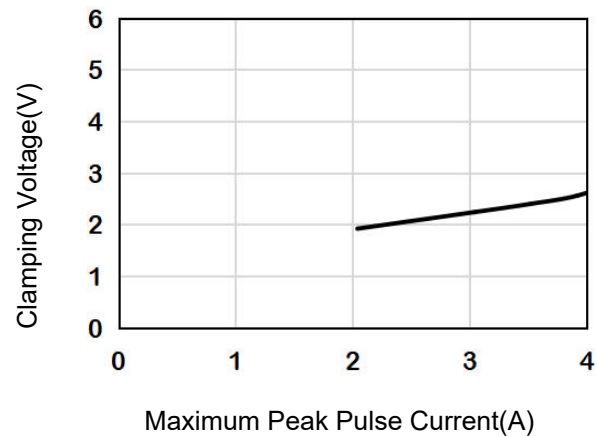

Recommended Soldering Conditions

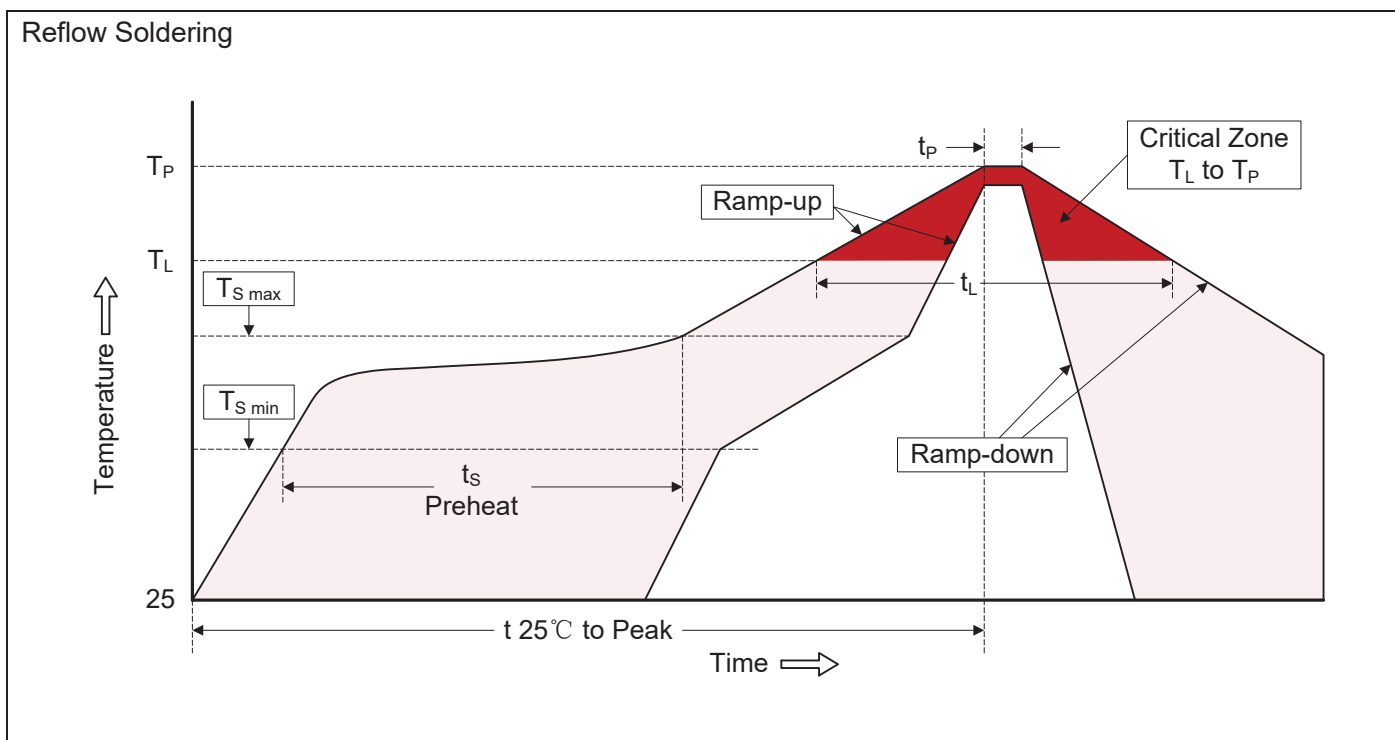

Recommended Conditions

Profile Feature	Pb-Free Assembly
Average ramp-up rate (T_L to T_P)	3°C/second max.
Preheat -Temperature Min ($T_{S\ min}$) -Temperature Max ($T_{S\ max}$) -Time (min to max) (t_s)	150°C 200°C 60-180 seconds
$T_{S\ max}$ to T_L -Ramp-up Rate	3°C/second max.
Time maintained above: -Temperature (T_L) -Time (t_L)	217°C 60-150 seconds
Peak Temperature (T_P)	260°C
Time within 5°C of actual Peak Temperature (t_P)	20-40 seconds
Ramp-down Rate	6°C/second max.
Time 25°C to Peak Temperature	8 minutes max.

Package Outline, DFN2510-10L

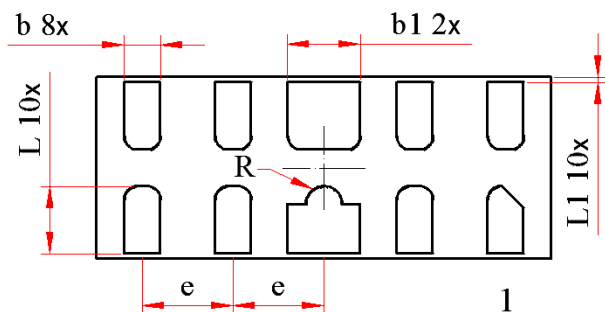

Bottom View

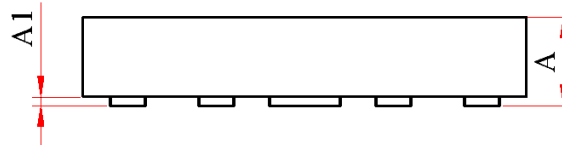

Side View

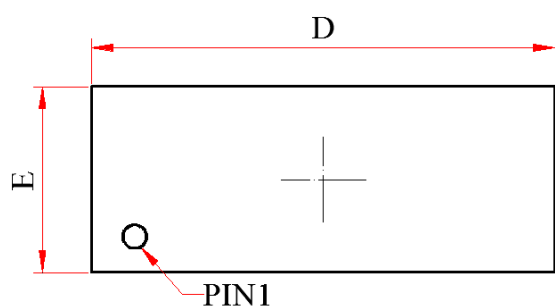

Top View

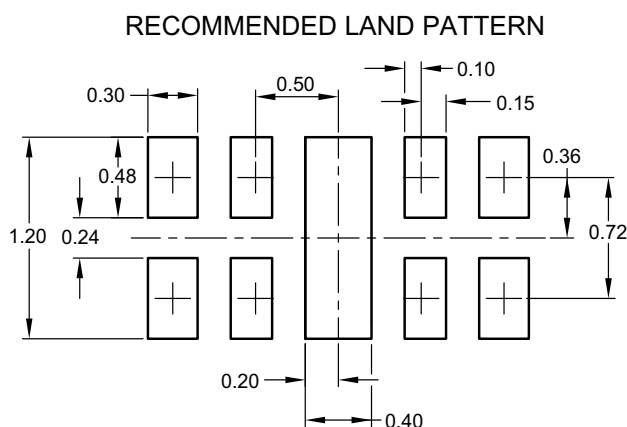

Symbol	Dimension In Millimeters			Dimension In Inches		
	Normal	Min	Max	Normal	Min	Max
A	--	0.450	0.550	--	0.018	0.026
A1	0.050	0.025	0.075	0.002	0.001	0.003
D	2.500	2.450	2.550	0.098	0.096	0.100
E	1.000	0.950	1.050	0.039	0.037	0.041
b	0.200	0.150	0.250	0.008	0.006	0.010
b1	0.400	0.350	0.450	0.016	0.014	0.018
L	0.370	0.320	0.420	0.015	0.013	0.017
L1	0.030	0.000	0.060	0.001	0.000	0.002
R	0.100 REF			0.004 REF		
e	0.500 BSC			0.020 BSC		

Tape and Reel Specification

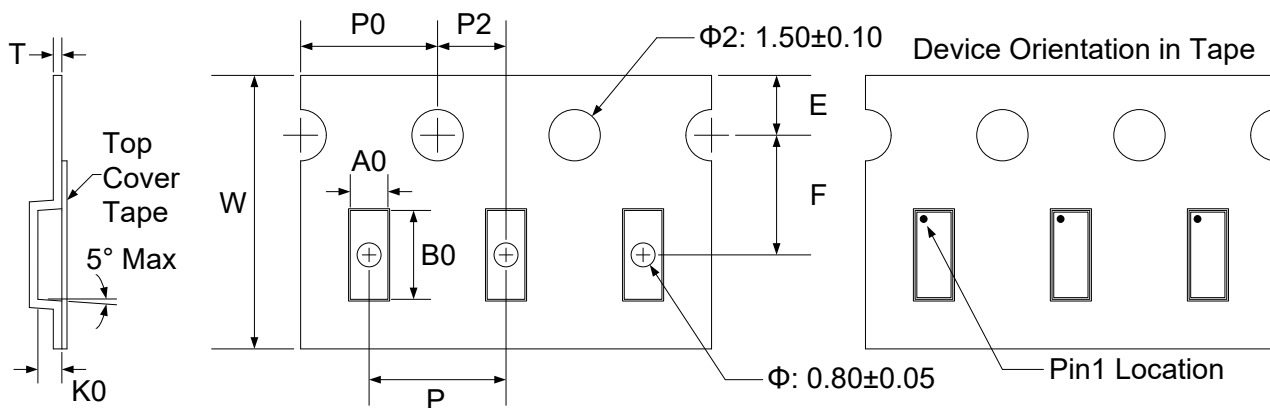

Symbol	W	A0	B0	K0	E	F	P	P0	P2	T
Dimensions (mm)	8.00 ± 0.3 -0.1	1.23 ± 0.05	2.7 ± 0.05	0.7 ± 0.05	1.75 ± 0.1	3.5 ± 0.05	4.0 ± 0.1	4.0 ± 0.1	2.0 ± 0.05	0.25 ± 0.02

Marking Codes

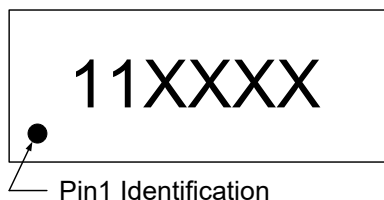

Note:

- (1) "11" is part number, fixed.
- (2) "XXXX" is the identification number.

Ordering Information

Part Number	Working Voltage	Quantity Per Reel	Reel Size
TT0214SPX	1.5V	3,000	7 Inch