

## Features

- Transient protection for high-speed data lines
 

IEC61000-4-2 (ESD)	±30kV (Air)
	±30kV (Contact)
IEC61000-4-5 (Lightning)	5.0A (8/20μs)
- Small package (1.6mm×1.6mm×0.75mm)
- Protects two I/O line (bidirectional)
- Low capacitance: 5.0pF@0V (Typical) (I/O-I/O)
- Low leakage current: 0.1μA@V<sub>RWM</sub> (Maximum)
- Low clamping voltage

## Description

TT0502PFX is a low capacitance Transient Voltage Suppressor (TVS) designed to provide electrostatic discharge (ESD) protection for high-speed data interfaces. With typical capacitance of 5.0pF only, TT0502PFX is designed to protect parasitic-sensitive systems against over-voltage and over-current transient events. It complies with IEC61000-4-2 (ESD), Level 4 (±15kVair, ±8kVcontact discharge), IEC61000-4-4 (electrical fast transient-EFT) (40A, 5/50 ns), very fast charged device model (CDM) ESD and cable discharge event (CDE), etc.

TT0502PFX uses small SOT-523 package. Each TT0502PFX device can protect two high-speed data lines. The low clamping voltage of the TT0502PFX guarantees a minimum stress on the protected IC.

## Applications

- Mobile Phones and accessories
- Desktops, Servers and Notebook
- Hand held portable
- Digital Cameras
- Computer Interfaces Protection
- Serial and Parallel Ports Protection
- Control Signal Lines Protection

## Mechanical Characteristics

- Package: SOT-523
- Marking: Part number
- Packaging: Tape and Reel
- ROHS compliant

## Circuit Diagram

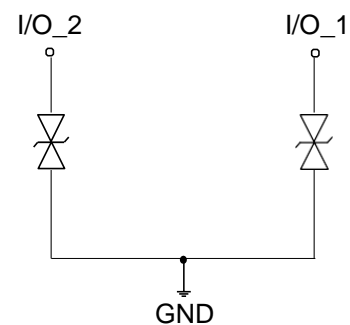

## Pin Configuration

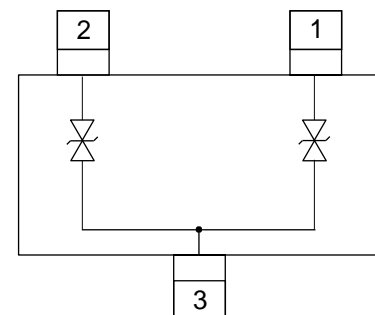

SOT-523  
(Top View)



## Typical Performance Characteristics

**TLP Measurement of I/O to I/O**

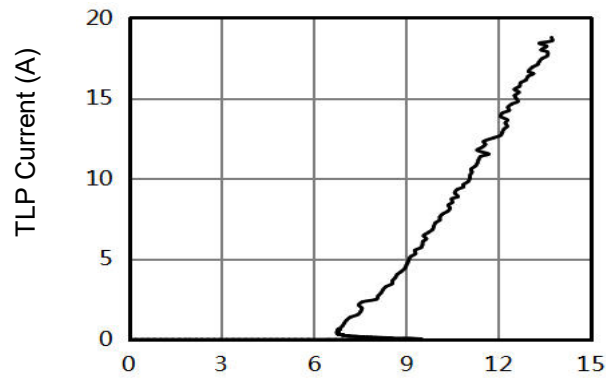

**Capacitance vs Reverse Voltage IO to IO**

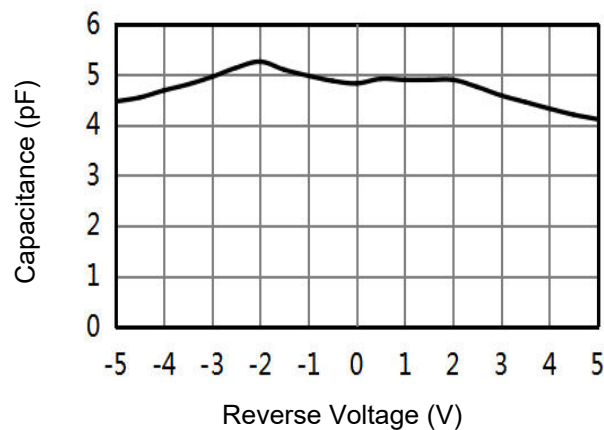

**8/20us Current IO to IO**

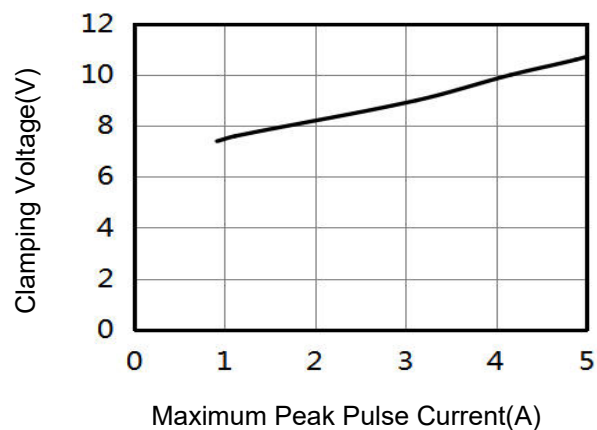

## Recommended Soldering Conditions

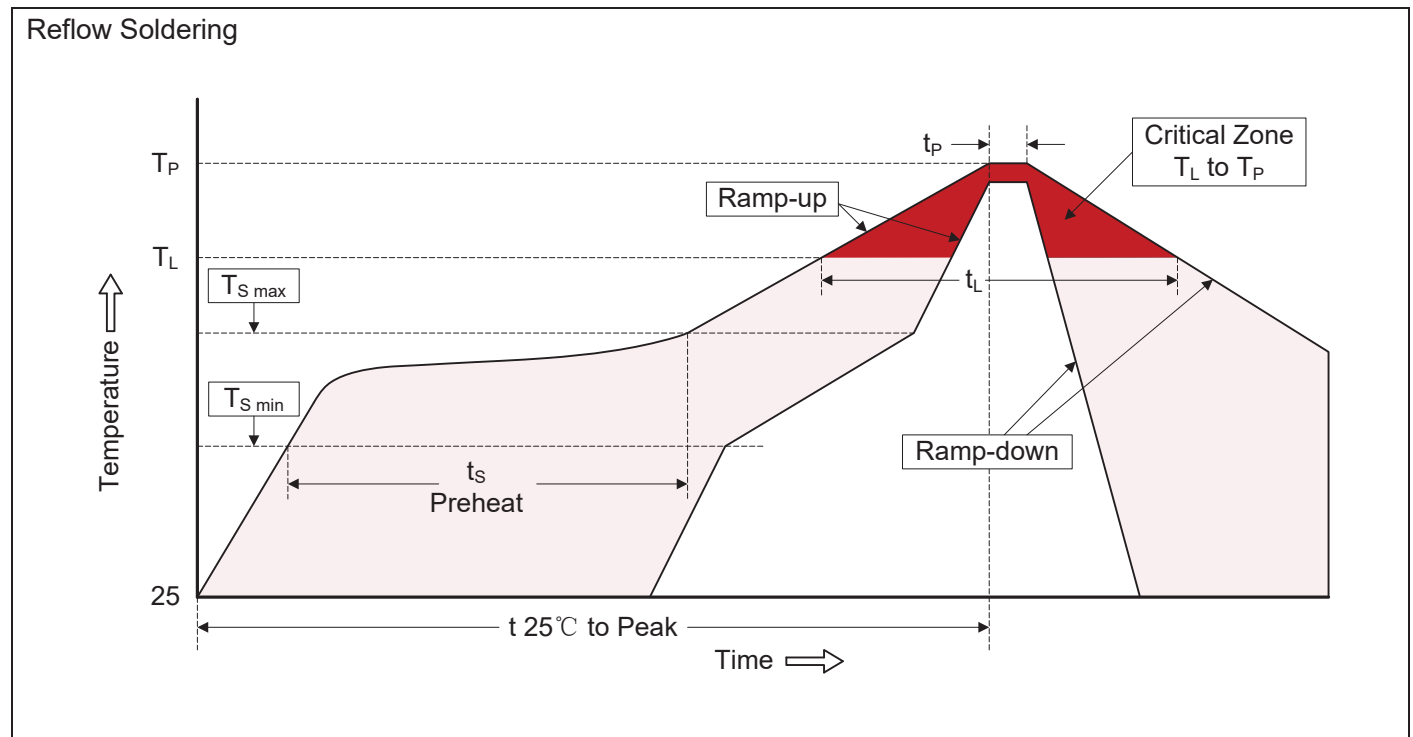

### Recommended Conditions

Profile Feature	Pb-Free Assembly
Average ramp-up rate ( $T_L$ to $T_P$ )	3°C/second max.
Preheat -Temperature Min ( $T_{S\ min}$ ) -Temperature Max ( $T_{S\ max}$ ) -Time (min to max) ( $t_s$ )	150°C 200°C 60-180 seconds
$T_{S\ max}$ to $T_L$ -Ramp-up Rate	3°C/second max.
Time maintained above: -Temperature ( $T_L$ ) -Time ( $t_L$ )	217°C 60-150 seconds
Peak Temperature ( $T_P$ )	260°C
Time within 5°C of actual Peak Temperature ( $t_P$ )	20-40 seconds
Ramp-down Rate	6°C/second max.
Time 25°C to Peak Temperature	8 minutes max.

## Package Outline

- SOT-523 package

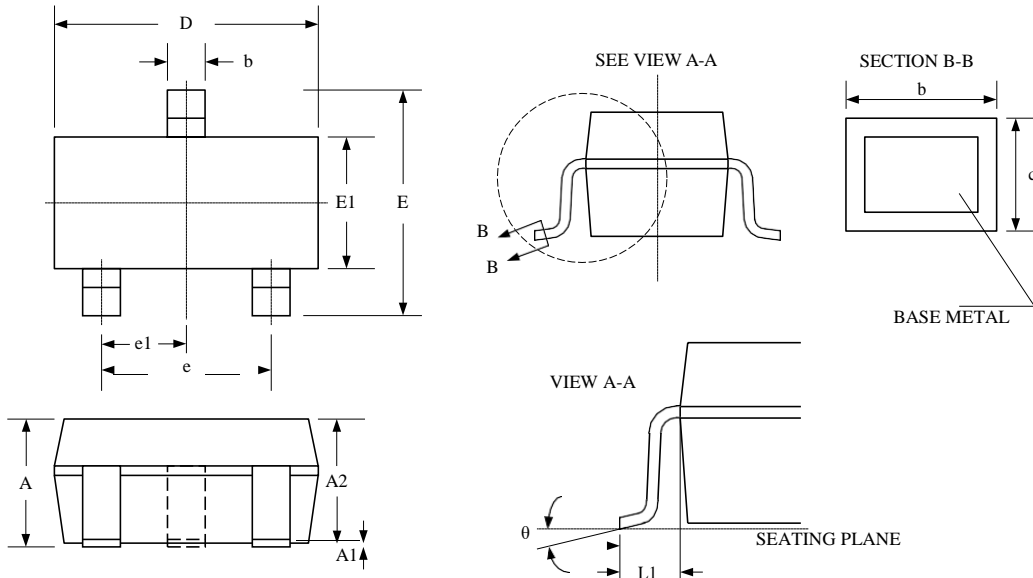

Package Dimensions (Controlling dimensions are in millimeters)

Symbol	Dimensions (mm)			Dimensions (Inches)		
	Minimum	Typical	Maximum	Minimum	Typical	Maximum
A	0.600	—	0.900	0.023	—	0.035
A1	0.000	—	0.100	0.000	—	0.004
A2	0.600	0.750	0.800	0.023	0.030	0.031
b	0.150	—	0.300	0.005	—	0.012
c	0.100	—	0.200	0.003	—	0.008
D	1.500	1.600	1.700	0.059	0.063	0.067
e	1.00 BSC			0.039 BSC		
e1	0.50 BSC			0.020 BSC		
E	1.450	1.600	1.750	0.057	0.063	0.069
E1	0.750	0.800	0.850	0.029	0.031	0.033
L1	0.220 REF			0.009 REF		
$\theta$	0°	—	8°	0°	—	8°

## Tape and Reel Specification

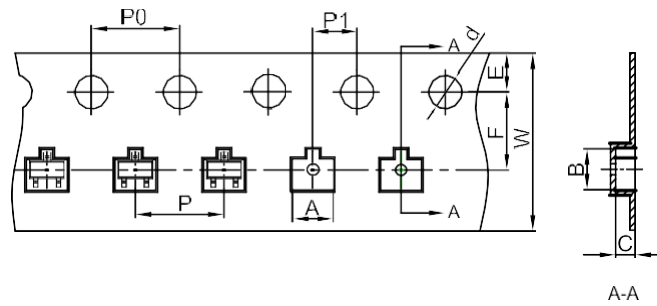

Dimensions are in millimeter										
Pkg type	A	B	C	d	E	F	P0	P	P1	W
SOT-523	1.85	1.85	0.875	Ø1.50	1.75	3.50	4.00	4.00	2.00	8.00

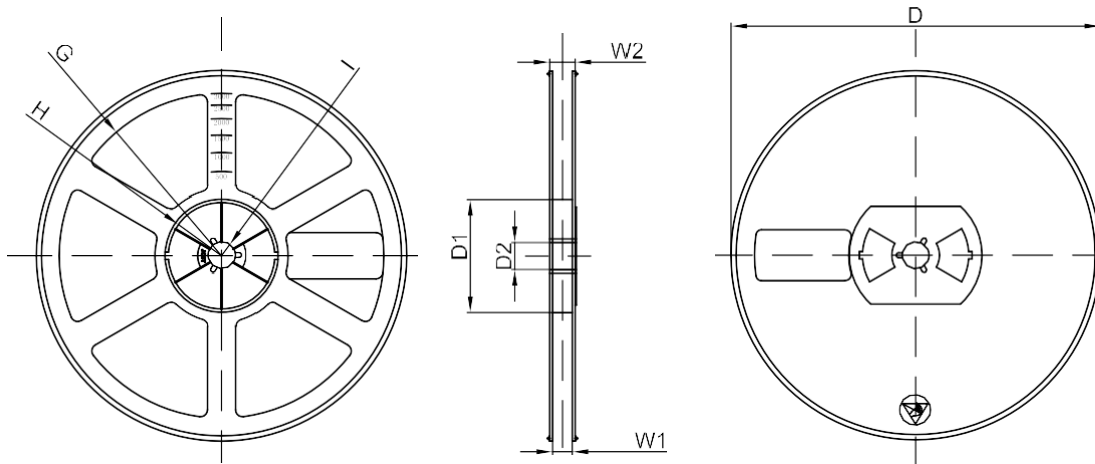

Dimensions are in millimeter								
Reel Option	D	D1	D2	G	H	I	W1	W2
7" Dia	Ø178.00	54.40	13.00	R78.00	R25.60	R6.50	9.50	12.30
Tolerance	+/-2	+/-1	+/-1	+/-1	+/-1	+/-1	+/-1	+/-1

## Marking Codes

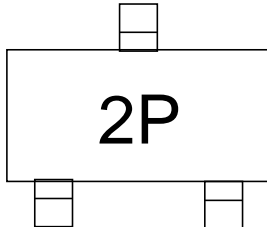

**Note:**

(1) "2P" is part number.

## Ordering Information

Part Number	Working Voltage	Quantity Per Reel	Reel Size
TT0502PFX	5.0V	3,000	7 Inch