

Features

- ❑ Transient protection for super-speed data lines
IEC 61000-4-2 (ESD) ±25kV (Air)
±17kV (Contact)
IEC 61000-4-4 (EFT) 40A (5/50 ns)
Cable Discharge Event (CDE)
- ❑ ESD protection for super-speed differential signal (above 5Gb/s) channels
- ❑ Fast turn-on and low clamping voltage
- ❑ Protects six data lines and one VCC line
- ❑ Ultra-low capacitance: 0.40 pF Typical (I/O-GND)
- ❑ Low leakage current: 0.1µA @ V_{RWM} (Typical)
- ❑ Back-drive protection for power-down mode
- ❑ Each I/O pin can withstand over 1000 ESD strikes for ±8kV contact discharge
- ❑ ROHS compliant

Description

TT0536STX is an ultra-low capacitance Transient Voltage Suppressor (TVS) designed to provide electrostatic discharge (ESD) protection for super-speed data interfaces. With typical capacitance of 0.4 pF only, TT0536STX is designed to protect parasitic-sensitive systems against over-voltage and over-current transient events. It complies with IEC 61000-4-2 (ESD), Level 4 (±15kV air, ±8kV contact discharge), IEC 61000-4-4 (electrical fast transient - EFT) (40A, 5/50 ns), very fast charged device model (CDM) ESD and cable discharge event (CDE), etc.

TT0536STX uses an DFN4120-10L package. Each TT0536STX device can protect six super-speed data lines and one VCC line. The combined features of ultra-low capacitance, small size and high ESD robustness make TT0536STX ideal for super-speed data ports and high-frequency lines (e.g., HDMI & DVI) applications. The low clamping voltage of the TT0536STX guarantees a minimum stress on the protected IC.

Applications

- ❑ USB3.0 Power and Data Line Protection
- ❑ Desktops, Servers and Notebooks
- ❑ MDDI Ports
- ❑ Display Ports
- ❑ High Definition Multi-Media Interface (HDMI)
- ❑ Digital Visual Interfaces (DVI)

Mechanical Characteristics

- ❑ DFN4120-10L package
- ❑ Flammability Rating: UL 94V-0
- ❑ Marking: Part number
- ❑ Packaging: Tape and Reel

Circuit Diagram

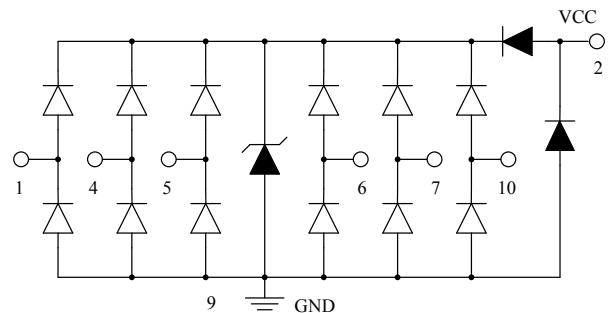

Pin Configuration

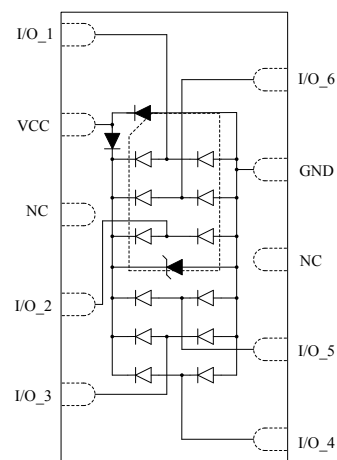

DFN4120-10L

(Top View, not to scale)



Absolute Maximum Rating

Symbol	Parameter	Value	Units
I_{PP}	Peak Pulse Current($t_p=8/20\mu s$) (I/O pins)	4.5	A
V_{ESD}	ESD per IEC 61000-4-2(Air) ESD per IEC 61000-4-2 (Contact)	± 25 ± 17	kV
T_{OPT}	Operating Temperature	-55/+125	°C
T_{STG}	Storage Temperature	-55/+150	°C

Electrical Characteristics (T = 25°C)

Symbol	Parameter
V_{RWM}	Nominal Reverse Working Voltage
I_R	Reverse Leakage Current @ V_{RWM}
V_{BR}	Reverse Breakdown Voltage @ I_T
I_T	Test Current for Reverse Breakdown
V_C	Clamping Voltage @ I_{PP}
I_{PP}	Maximum Peak Pulse Current
C_{ESD}	Parasitic Capacitance
V_R	Reverse Voltage
f	Small Signal Frequency
I_F	Forward Current
V_F	Forward Voltage @ I_F

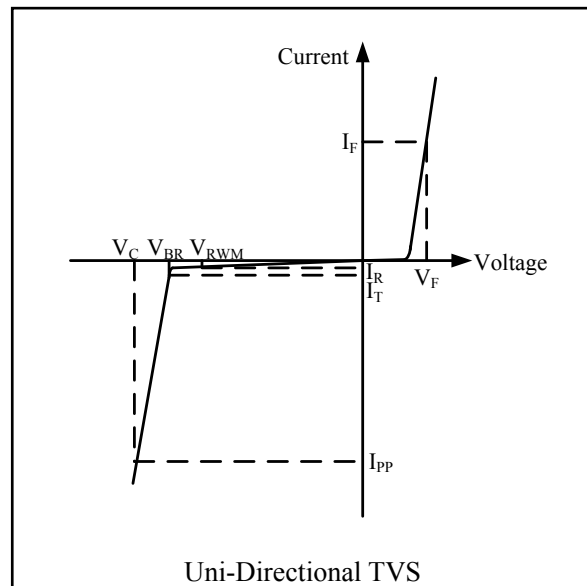

Symbol	Test Condition	Minimum	Typical	Maximum	Units
V_{RWM}				5.0	V
I_R	$V_{RWM} = 5V, T = 25^\circ C$ Between Any Pin and GND		0.1	1.0	μA
V_{BR}	$I_T = 1mA$ Between Any Pin and GND	6.0	8.0	10.0	V
V_C	$I_{PP} = 1A, t_p = 8/20\mu s$ Between Any I/O Pin and GND			12	V
C_{ESD}	$V_R = 0V, f = 1MHz$ Between Any I/O Pin and GND		0.4	0.6	pF
C_{ESD}	$V_R = 0V, f = 1MHz$ Between I/O and I/O		0.2	0.3	pF

Voltage Sweeping of I/O to GND

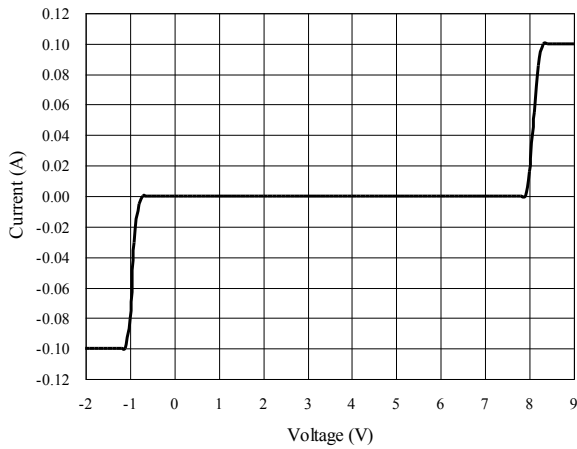

Insertion Loss S21 of I/O to GND

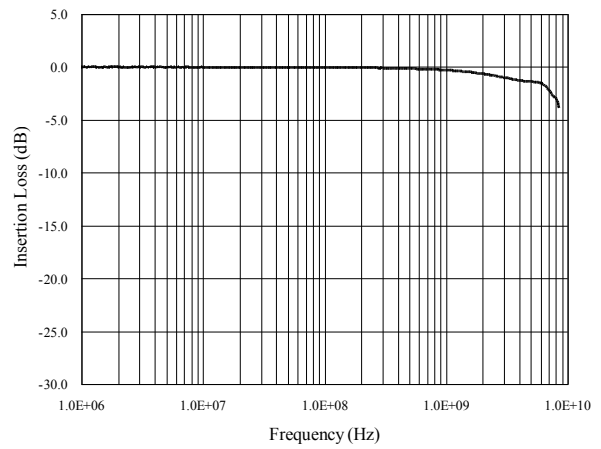

Capacitance vs. Voltage of I/O to GND (f = 1MHz)

Capacitance vs. Reverse Voltage

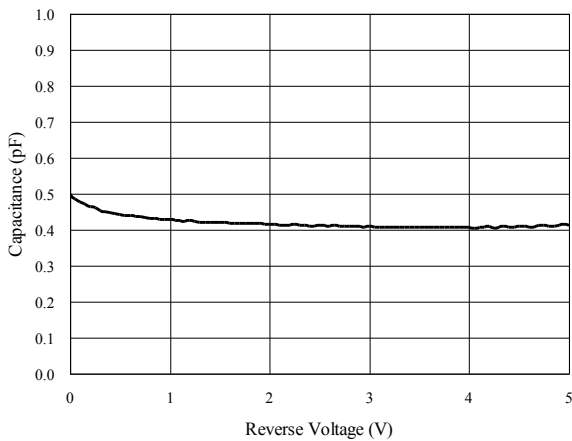

Normalized Capacitance vs. Reverse Voltage

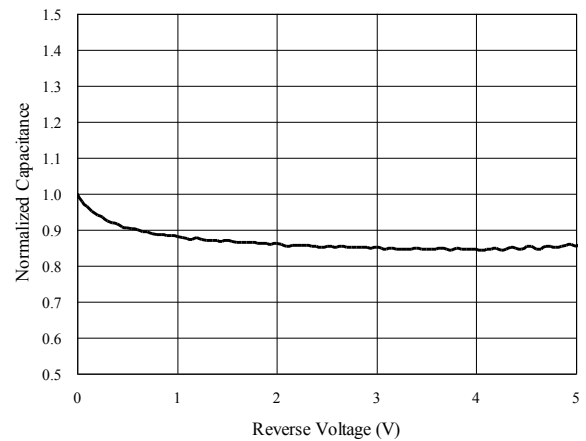

ESD Clamping of I/O to GND (+8kV Contact per IEC 61000-4-2)

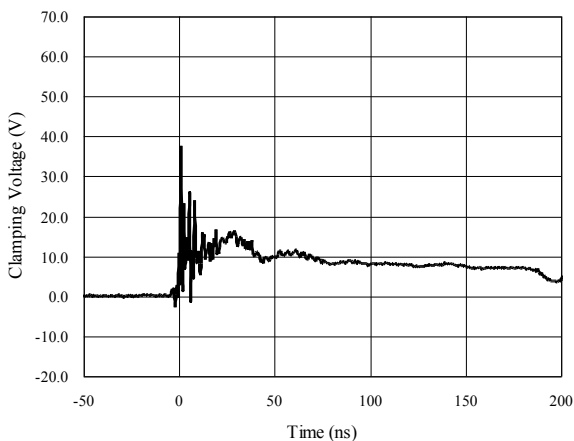

ESD Clamping of I/O to GND (-8kV Contact per IEC 61000-4-2)

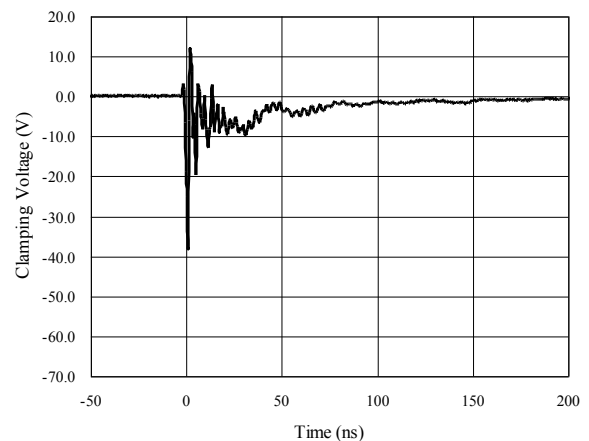

Application Information

Pin Connection in PCB

TT0536ST provides ESD protection for six data lines and one power rail line simultaneously. The pin connection is shown in Figure 1.

Six parallel data lines, from inner IC to I/O port connector, could connect to TT0536STX six I/O pins directly. Pin 9 of TT0536STX is the GND pin, which should connect to the GND of PCB. The wire should be as short as possible in order to minimize the parasitic inductance. Pin 2 of TT0536STX is the VCC pin, which should connect to the VCC rail of PCB.

In some cases, systems are not allowed to be reset or restart after zapping ESD stress at the I/O port connector. Under this situation, to enhance the sustainable ESD level, a 0.1 μ F capacitor can be used between the VCC and GND rails. Place the capacitor as close as possible to TT0536STX.

In some cases, VCC rail is not presented on the PCB. Under this situation, the pin 2 of TT0536STX can be left as floating. The pin connection is shown in Figure 2.

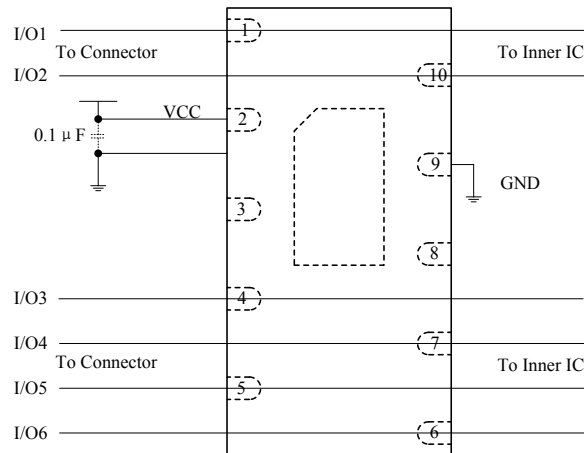

Figure 1 TT0536STX pin connection in PCB providing data lines and power rail line protection.

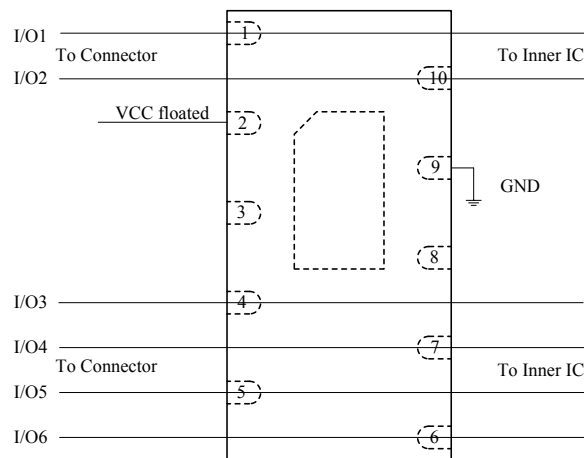

Figure 2 TT0536STX pin connection in PCB providing data line protection. VCC pin is left as floating when no VCC rail is presented in PCB.

Application Information

USB3.0 Protection for Super Speed Differential signals

TT0536STX provides ESD protection for super-speed data lines. Thus, a lot of kinds of high speed I/O ports can be the applications of TT0536STX, especially, the USB3.0 port.

USB3.0 is expected to transmit and receive above 5Gb/s data, which needs differential signaling. For differential signaling, keep the differential impedance at constant is the most importance.

ESD protection devices have an inherent junction capacitance. Usually, this added capacitance on a USB3.0 port will drop the impedance of the

differential pair to interfere with the signaling. TT 0536 ST X presents only 0.30 pF maximum capacitance to each differential signal while being rated to handle 8kV ESD contact/air discharges as outlined in IEC 61000-4-2 and providing a low clamping voltage to protect the downstream devices.

Therefore, TT0536STX is the most suitable ESD protector for USB3.0 I/O ports and other high speed, above 5Gb/s, I/O ports in any electronic product. Figure 3 shows the pin connection example for USB3.0 I/O ports.

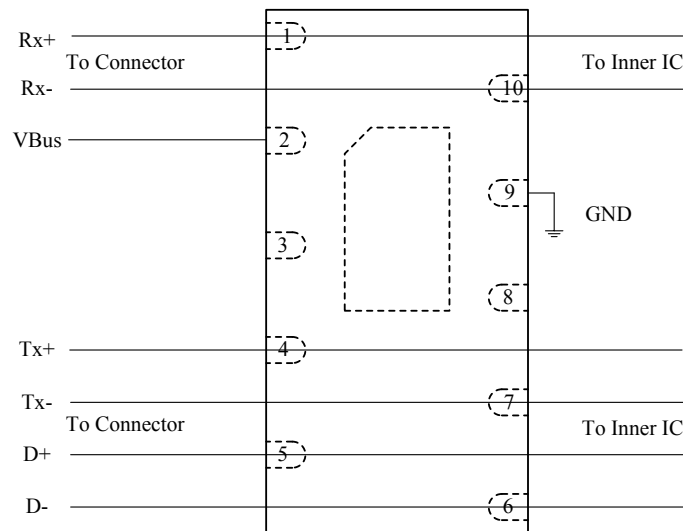
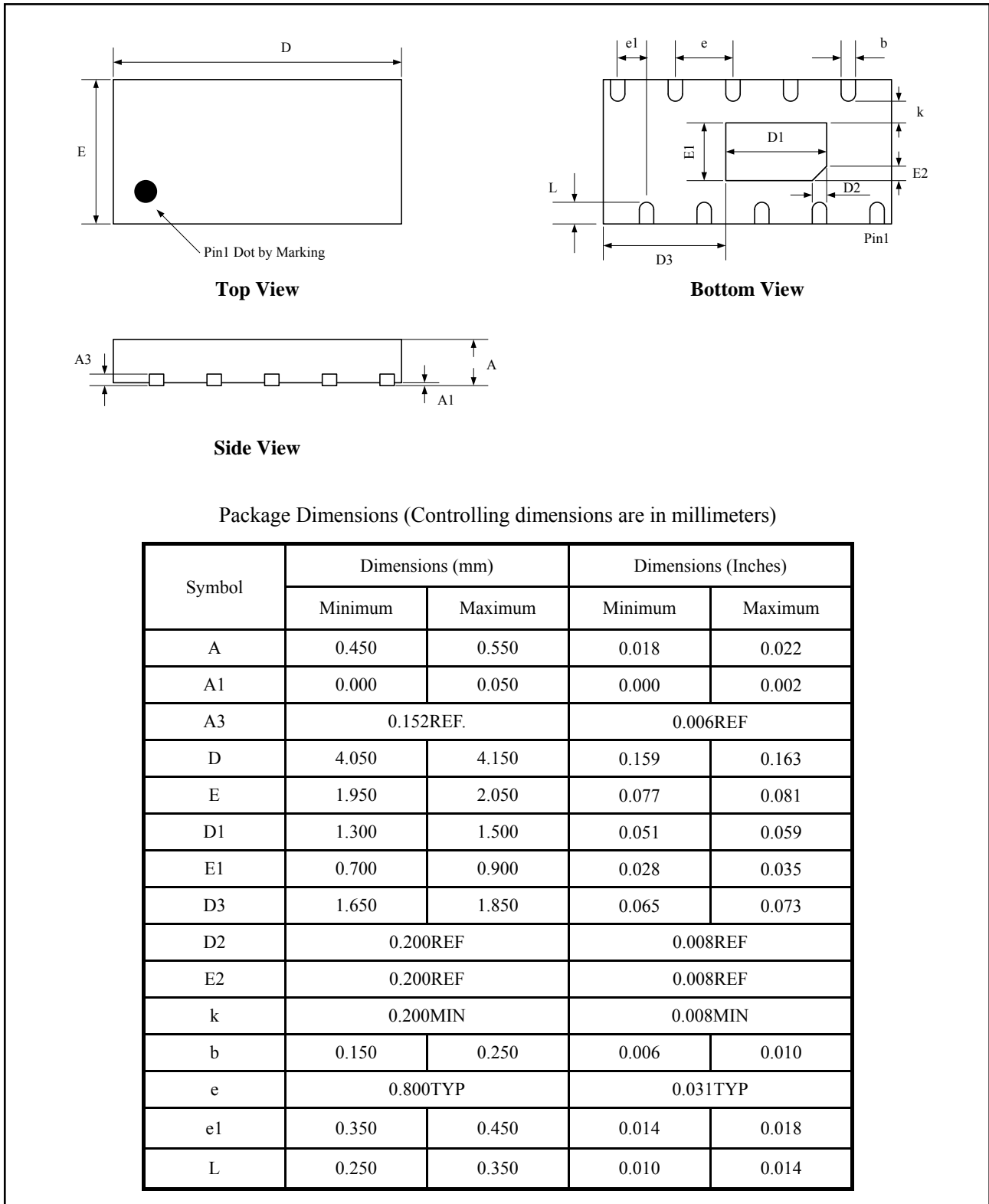

Figure 3 TT0536STX pin connection for USB3.0 protection.

Package Outline

- DFN4120-10L package
- MSL-1 Level



Tape and Reel Specification

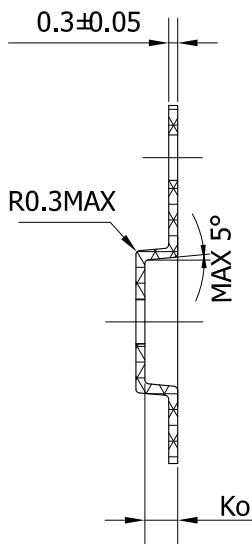
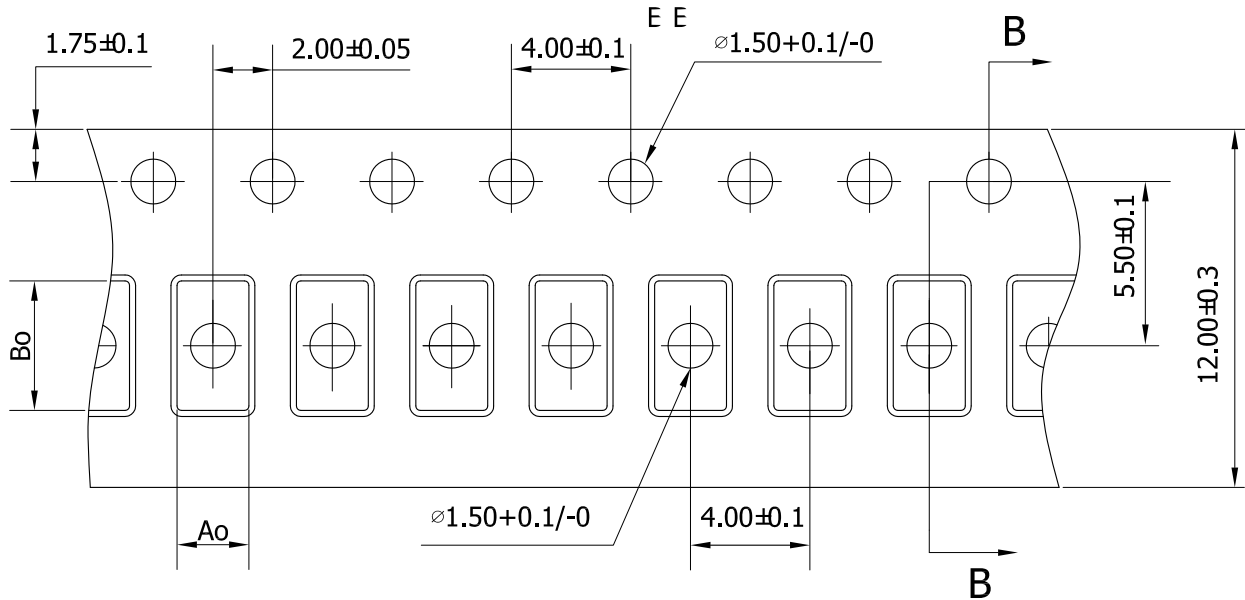

$A_o=2.30\pm0.1$
 $B_o=4.40\pm0.1$
 $K_o=0.80\pm0.1$

NOTES:
 1 10 SPROCKET HOLE PITCH CUMULATIVE TOLERANCE $\neq 0.2$
 2 CAMBER IN COMPLIANCE WITH EIA 481
 3 POCKET POSITION RELATIVE TO SPROCKET HOLE MEASURED
 AS TRUE POSITION OF POCKET, NOT POCKET HOLE

Marking Codes

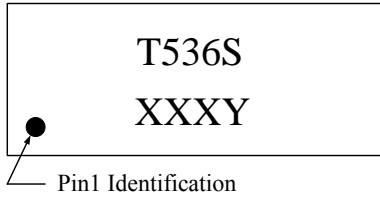

Note:

- (1) "T536S" is part number.
- (2) "XXX" is the last 3 characters of the wafer's Lot No.,
"Y" is the internal code.

Ordering Information

Part Number	Working Voltage	Quantity Per Reel	Reel Size
TT0536STX	5V	3,000	7 Inch