

Features

- ❑ Transient protection for high-speed data lines
IEC 61000-4-2 (ESD) ±15kV (Air)
±15kV (Contact)
IEC 61000-4-4 (EFT) 40A (5/50 ns)
Cable Discharge Event (CDE)
- ❑ Package optimized for high-speed lines
- ❑ Ultra-small package (1.0mm×0.6mm×0.55mm)
- ❑ Protects one data, control or power line
- ❑ Low capacitance: 2.0pF (Typical)
- ❑ Low leakage current: 0.1μA @ V_{RWM} (Typical)
- ❑ Low clamping voltage
- ❑ Each I/O pin can withstand over 1000 ESD strikes for ±15kV contact discharge

Description

TT0521VBX is a low- capacitance Transient Voltage Suppressor (TVS) designed to provide electrostatic discharge (ESD) protection for high-speed data interfaces. With typical capacitance of 2.0pF only, TT0521VBX is designed to protect parasitic-sensitive systems against over-voltage and over-current transient events. It complies with IEC 61000-4-2 (ESD), Level 4 (±15kV air, ±8kV contact discharge), IEC 61000-4-4 (electrical fast transient - EFT) (40A, 5/50 ns), very fast charged device model (CDM) ESD and cable discharge event (CDE), etc.

TT0521VBX uses ultra-small DFN1006-2L package. Each TT0521VBX device can protect one high-speed data line. It offers system designers flexibility to protect single data line where space is a premium concern. The combined features of low capacitance, ultra-small size and high ESD robustness make TT0521VB ideal for high-speed data port and high-frequency line (e.g., USB 2.0 & antenna line) applications, such as cellular phones and HD visual devices.

Applications

- ❑ Serial ATA
- ❑ PCI Express
- ❑ Desktops, Servers and Notebooks
- ❑ Cellular Phones
- ❑ MDDI Ports
- ❑ USB2.0 Power and Data Line Protection
- ❑ Display Ports
- ❑ Digital Visual Interfaces (DVI)

Mechanical Characteristics

- ❑ DFN1006-2L package
- ❑ Flammability Rating: UL 94V-0
- ❑ Marking: Part number
- ❑ Packaging: Tape and Reel

Circuit Diagram



Pin Configuration

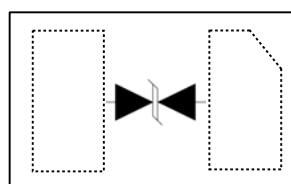

DFN1006-2L
(Top View)

Absolute Maximum Rating

Symbol	Parameter	Value	Units
I_{PP}	Peak Pulse Current (8/20 μ s)	2.5	A
P_{PK}	Peak Pulse Power (8/20 μ s)	40	W
V_{ESD}	ESD per IEC61000-4-2 (Air) ESD per IEC61000-4-2 (Contact)	± 15 ± 15	kV
T_{OPT}	Operating Temperature	-55/+125	$^{\circ}$ C
T_{STG}	Storage Temperature	-55/+150	$^{\circ}$ C

Electrical Characteristics (T = 25 $^{\circ}$ C)

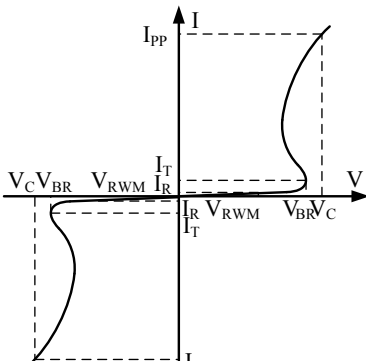
Symbol	Parameter	Diagram
V_{RWM}	Nominal Reverse Working Voltage	 <p>Bi-Directional TVS</p>
I_R	Reverse Leakage Current @ V_{RWM}	
V_{BR}	Reverse Breakdown Voltage @ I_T	
I_T	Test Current for Reverse Breakdown	
V_C	Clamping Voltage @ I_{PP}	
I_{PP}	Maximum Peak Pulse Current	
C_{ESD}	Parasitic Capacitance	
I_F	Forward Current	
V_F	Forward Voltage @ I_F	

Symbol	Test Condition	Minimum	Typical	Maximum	Units
V_{RWM}				5.0	V
I_R	$V_{RWM} = 5V, T = 25^{\circ}C$ Between I/O and I/O		0.1	1.0	μ A
V_{BR}	$I_T = 1mA$ Between I/O and I/O	6.0	8.0	10.0	V
V_C	$I_{PP} = 2.5A, t_p = 8/20\mu s$ Between I/O and I/O		11.0		V
V_C	$I_{PP} = 8.0A, t_p = 100ns^{(1)}$		12.7		V
	$I_{PP} = 16.0A, t_p = 100ns^{(1)}$		15.5		V
R_{dyn}	$I_{PP} = 12.0A, t_p = 100ns^{(1)}$		0.35		Ω
C_{ESD}	$V_R = 0V, f = 1MHz$ Between I/O and I/O		2.0	2.5	pF

Notes:(1)Measurements performed using a 100ns Transmission Line Pulse(TLP) system,Between I/O and GND.

Typical Performance Characteristics

TLP Measurement of I/O to I/O

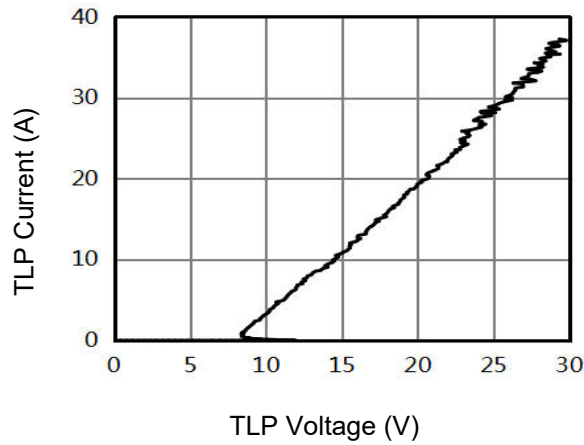

Capacitance vs Reverse Voltage I/O to I/O

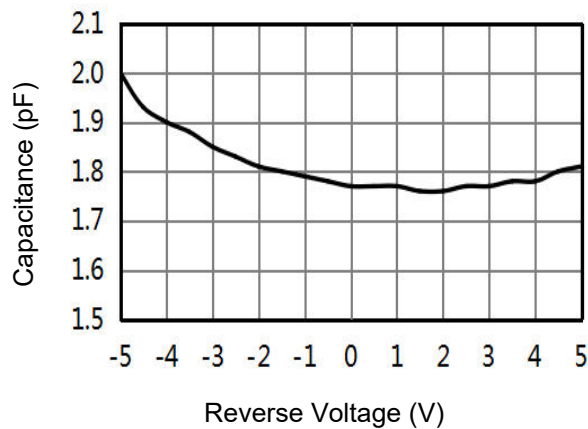

8/20us Current I/O to I/O

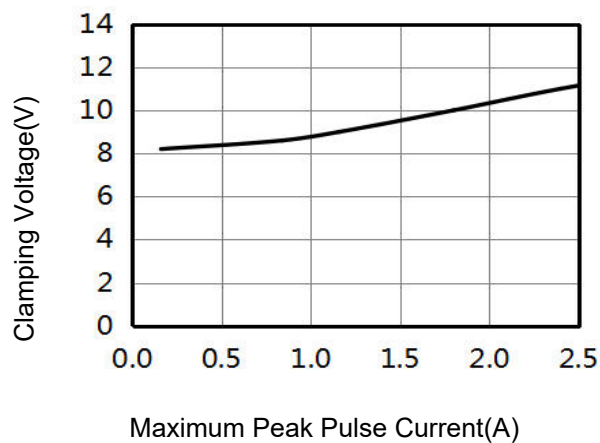

Package Outline

- ❑ DFN1006-2L package
- ❑ 2 leads, very small package
- ❑ MSL-1

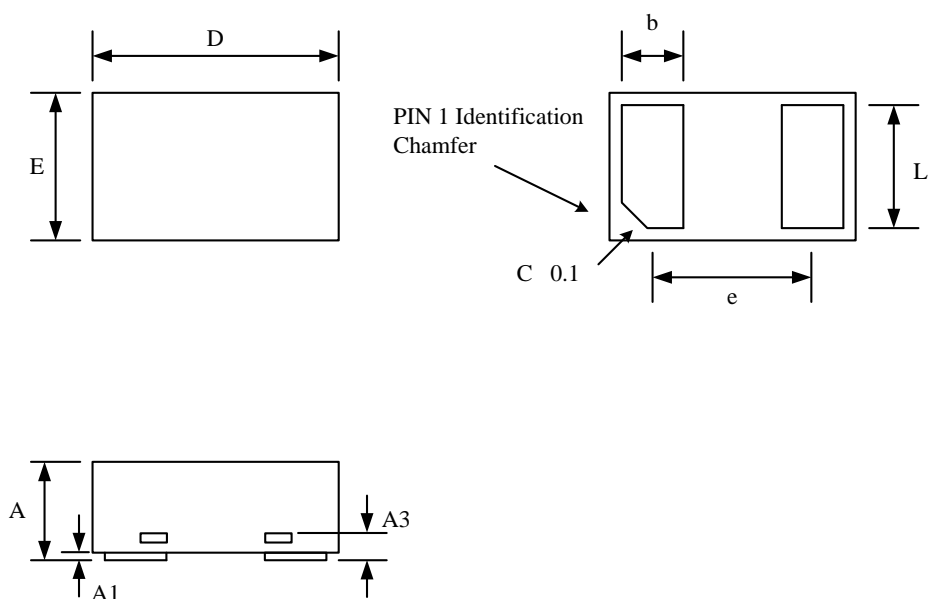

Package Dimensions (Controlling dimensions are in millimeters)

Symbol	Dimensions In Millimeters		Dimensions In Inches	
	Minimum	Maximum	Minimum	Maximum
A	0.400	0.550	0.016	0.022
A1	0.000	0.050	0.000	0.002
A3	0.125 REF		0.005 REF	
D	0.950	1.050	0.037	0.041
E	0.550	0.650	0.022	0.026
b	0.200	0.300	0.008	0.012
e	0.650 BSC		0.026 BSC	
L	0.450	0.550	0.018	0.022

Tape and Reel Specification

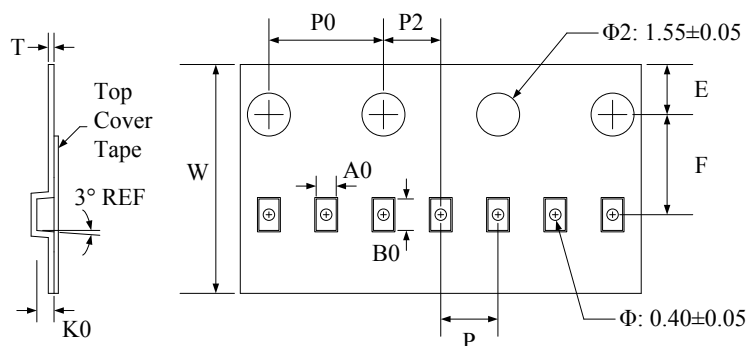

Symbol	W	A0	B0	K0	E	F	P	P0	P2	T
Dimensions (mm)	8.00±0.1	0.7±0.05	1.15±0.05	0.55±0.05	1.75±0.1	3.5±0.05	2.0±0.1	4.0±0.1	2.0±0.05	0.2±0.05

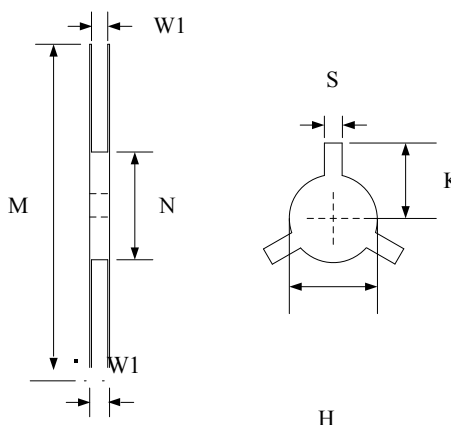
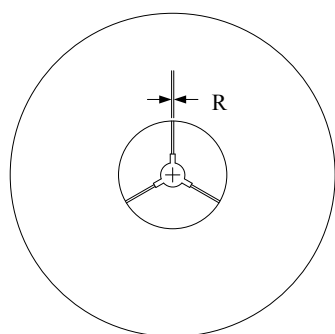

Symbol	Reel Size	M	N	W	W	H	S	K	R
Dimensions (mm)	Φ178	178.0±1.0	60.0±1.0	11.5±0.5	9.0±0.5	13.0±0.5	2.0±0.1	11.0±0.2	1.0±0.05

Marking Codes



Note:

- (1) "W" is part number, fixed
- (2) "X" is date code, which is the assembly month in three years, changing as (1~9, 0, A~Z)

Ordering Information

Part Number	Working Voltage	Quantity Per Reel	Reel Size
TT0521VBX	5V	10,000	7 Inch