

## Features

- ❑ Transient protection for high-speed data lines
  - IEC 61000-4-2 (ESD)  $\pm 27\text{kV}$  (Air)
  - $\pm 17\text{kV}$  (Contact)
  - IEC 61000-4-4 (EFT) 40A (5/50 ns)
  - Cable Discharge Event (CDE)
- ❑ Small package (2.9mm × 2.8mm × 1.4mm)
- ❑ Protects four data lines
- ❑ Low capacitance: 0.3pF Typical (I/O-I/O)
- ❑ Low leakage current: 0.1 $\mu\text{A}$  @  $V_{\text{RWM}}$  (Typical)
- ❑ Low clamping voltage
- ❑ Each I/O pin can withstand over 1000 ESD strikes for  $\pm 8\text{kV}$  contact discharge
- ❑ Green Part

## Description

TT0514TLX is an ultra-low capacitance Transient Voltage Suppressor (TVS) designed to provide electrostatic discharge (ESD) protection for high-speed data interfaces. With typical capacitance of 0.3pF only, TT0514TLX is designed to protect parasitic-sensitive systems against over-voltage and over-current transient events. It complies with IEC 61000-4-2 (ESD), Level 4 ( $\pm 15\text{kV}$  air,  $\pm 8\text{kV}$  contact discharge), IEC 61000-4-4 (electrical fast transient - EFT) (40A, 5/50 ns), very fast charged device model (CDM) ESD and cable discharge event (CDE), etc.

TT0514TLX uses small SOT23-6L package. Each TT0514TLX device can protect four high-speed data lines. The combined features of low capacitance, small size and high ESD robustness make TT0514TLX ideal for high-speed data ports and high-frequency lines (e.g., HDMI & DVI) applications. The low clamping voltage of the TT0514TLX guarantees a minimum stress on the protected IC.

## Applications

- ❑ Serial ATA
- ❑ PCI Express
- ❑ Desktops, Servers and Notebooks
- ❑ MDDI Ports
- ❑ USB 2.0/3.0 Power and Data Line Protection
- ❑ Display Ports
- ❑ High Definition Multi-Media Interface (HDMI)
- ❑ Digital Visual Interfaces (DVI)

## Mechanical Characteristics

- ❑ SOT23-6L package
- ❑ Flammability Rating: UL 94V-0
- ❑ Marking: Part number, Date
- ❑ Packaging: Tape and Reel

## Circuit Diagram

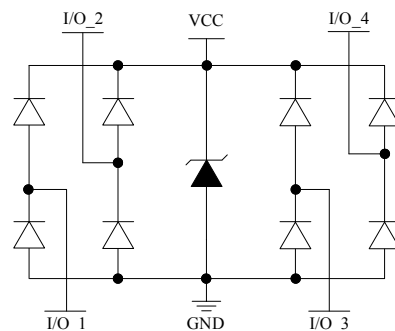

## Pin Configuration

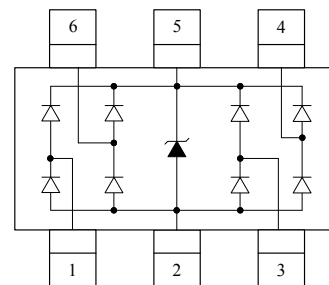

SOT23-6L  
(Top View)



### Absolute Maximum Rating

Symbol	Parameter	Value	Units
$I_{PP}$	Peak Pulse Current (8/20 $\mu$ s)	3	A
$P_{PK}$	Peak Pulse Power (8/20 $\mu$ s)	40	Watts
$V_{ESD}$	ESD per IEC 61000-4-2 (Air) ESD per IEC 61000-4-2 (Contact)	$\pm 27$ $\pm 17$	kV
$T_{OPT}$	Operating Temperature	-55 to +125	$^{\circ}$ C
$T_{STG}$	Storage Temperature	-55 to +150	$^{\circ}$ C

### Electrical Characteristics (T = 25 $^{\circ}$ C)

Symbol	Parameter
$V_{RWM}$	Nominal Reverse Working Voltage
$I_R$	Reverse Leakage Current @ $V_{RWM}$
$V_{BR}$	Reverse Breakdown Voltage @ $I_T$
$I_T$	Test Current for Reverse Breakdown
$V_C$	Clamping Voltage @ $I_{PP}$
$I_{PP}$	Maximum Peak Pulse Current
$C_{ESD}$	Parasitic Capacitance
$V_R$	Reverse Voltage
f	Small Signal Frequency
$I_F$	Forward Current
$V_F$	Forward Voltage @ $I_F$

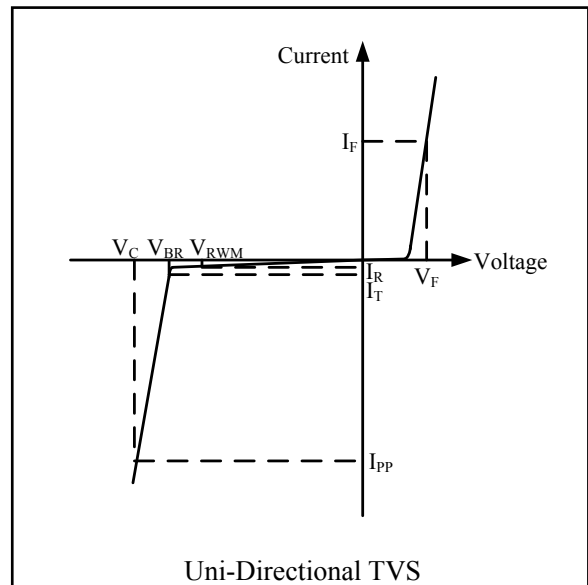

Symbol	Test Condition	Minimum	Typical	Maximum	Units
$V_{RWM}$				5.0	V
$I_R$	$V_{RWM} = 5V, T = 25^{\circ}C$ Between I/O and GND		0.1	1.0	$\mu$ A
$V_{BR}$	$I_T = 1mA$ Between I/O and GND	6.0	8.0	10.0	V
$V_C$	$I_{PP} = 1A, t_p = 8/20\mu s$ Between I/O and GND			12	V
$V_C$	$I_{PP} = 3A, t_p = 8/20\mu s$ Between I/O and GND			13	V
$R_{dyn}$	IEC61000-4-2 0-8KV, T=25 $^{\circ}$ C Contact, I/O to GND		0.44		$\Omega$
$R_{dyn}$	IEC61000-4-2 0-8KV, T=25 $^{\circ}$ C Contact, VCC to GND		0.18		$\Omega$
$C_{ESD}$	$V_R = 0V, f = 1MHz$ Between I/O and GND		0.6	0.8	pF
$C_{ESD}$	$V_R = 0V, f = 1MHz$ Between I/O and I/O		0.3	0.4	pF

### Voltage Sweeping of I/O to GND

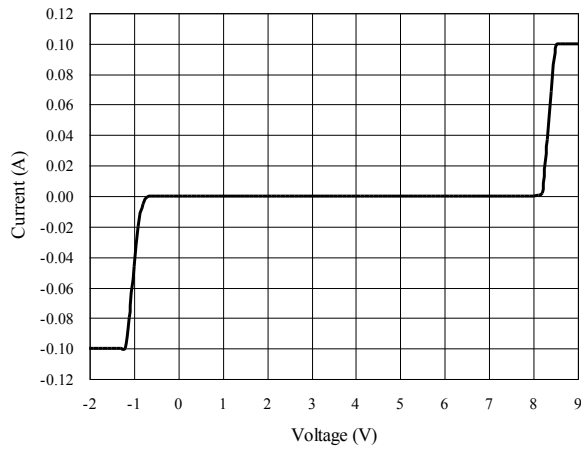

### Insertion Loss S21 of I/O to GND

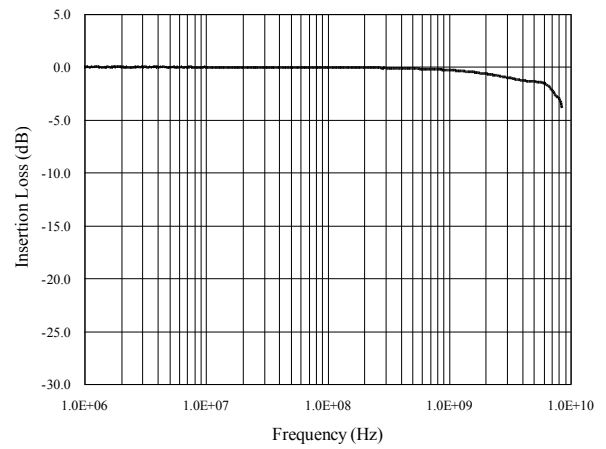

### Capacitance vs. Voltage of I/O to GND (f = 1MHz)

Capacitance vs. Reverse Voltage

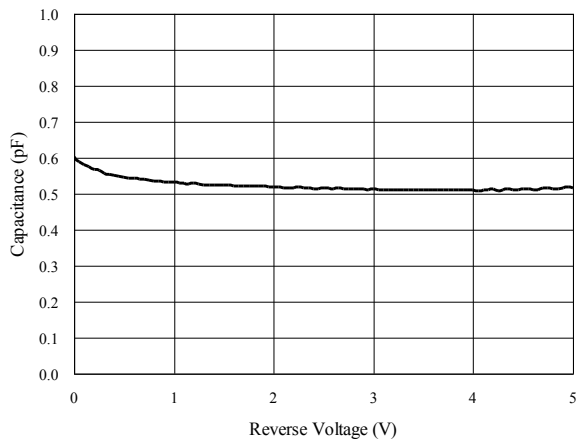

Normalized Capacitance vs. Reverse Voltage

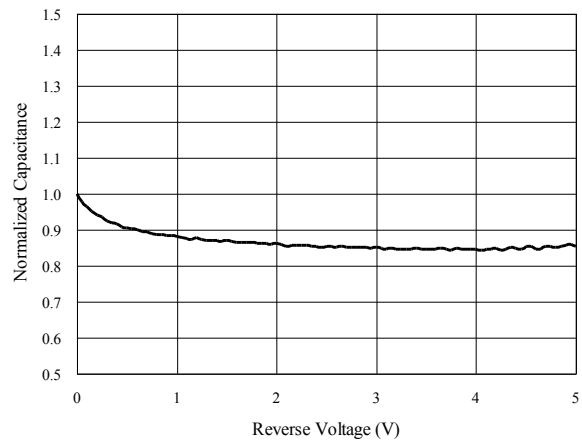

### ESD Clamping of I/O to GND (+8kV Contact per IEC 61000-4-2)

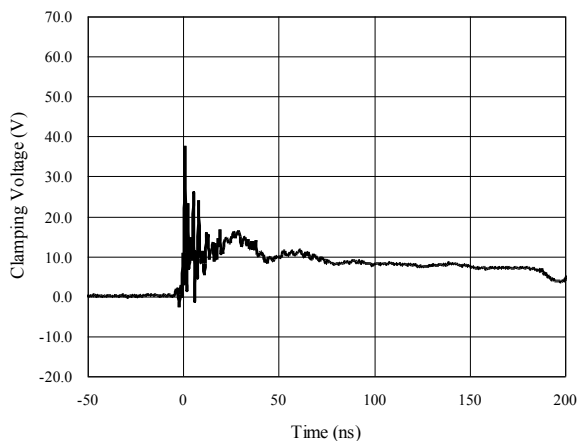

### ESD Clamping of I/O to GND (-8kV Contact per IEC 61000-4-2)

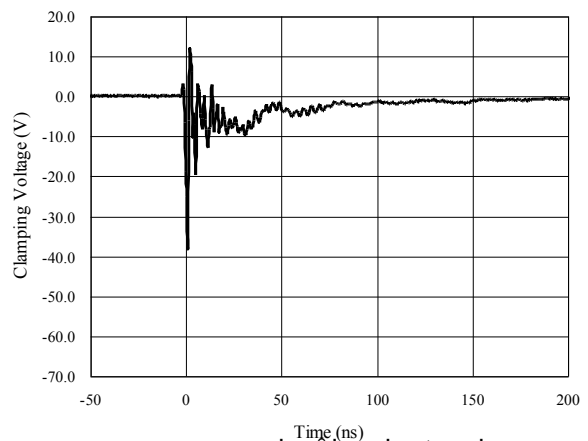

## Application Information

### Pin Connection in PCB

TT0514TLX is capable to provide ESD protection for four data lines simultaneously. The pin connection is shown in Figure 1.

Four parallel data lines, from inner IC to I/O port connector, could connect to TT0514TLX four I/O pins directly. Pin 2 of TT0514TLX is the negative reference pin, which should connect to the GND of PCB. The connection wires should be as short as possible in order to minimize the parasitic inductance.

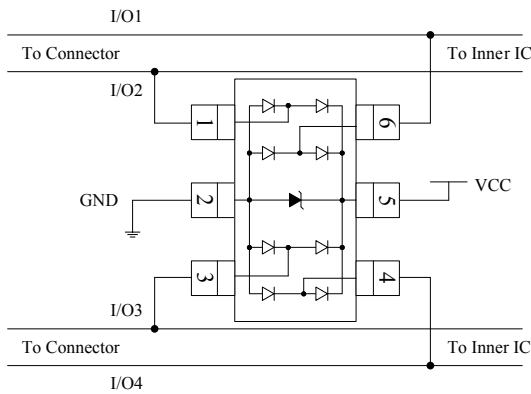

Figure 1 TT0514TLX pin connection in PCB

### PCB Layout Guidelines

For optimum ESD protection and the whole circuit performance, the following PCB layout guidelines are recommended:

- ❑ TT0514TLX GND pin to the PCB GND rail path should be as short as possible. It could reduce the ESD transient return path to GND.
- ❑ The vias connecting TT0514TLX VCC & GND pins to the PCB VCC & GND should be wide.
- ❑ Place TT0514TLX as close to the connector port as possible. It could reduce the parasitic inductance and restrict ESD coupling into adjacent traces.
- ❑ Avoid running critical signals near board edges.

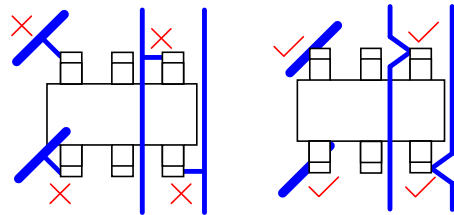
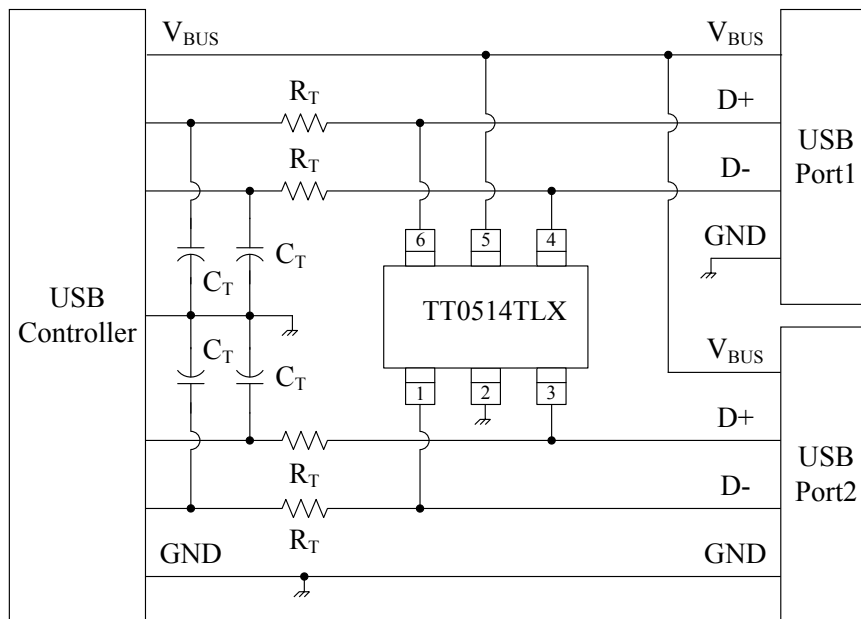

Figure 2 TT0514TLX Layout Guideline

## Universal Serial Bus ESD Protection



service@jy-electronics.com.cn

**Application Information (continued)**

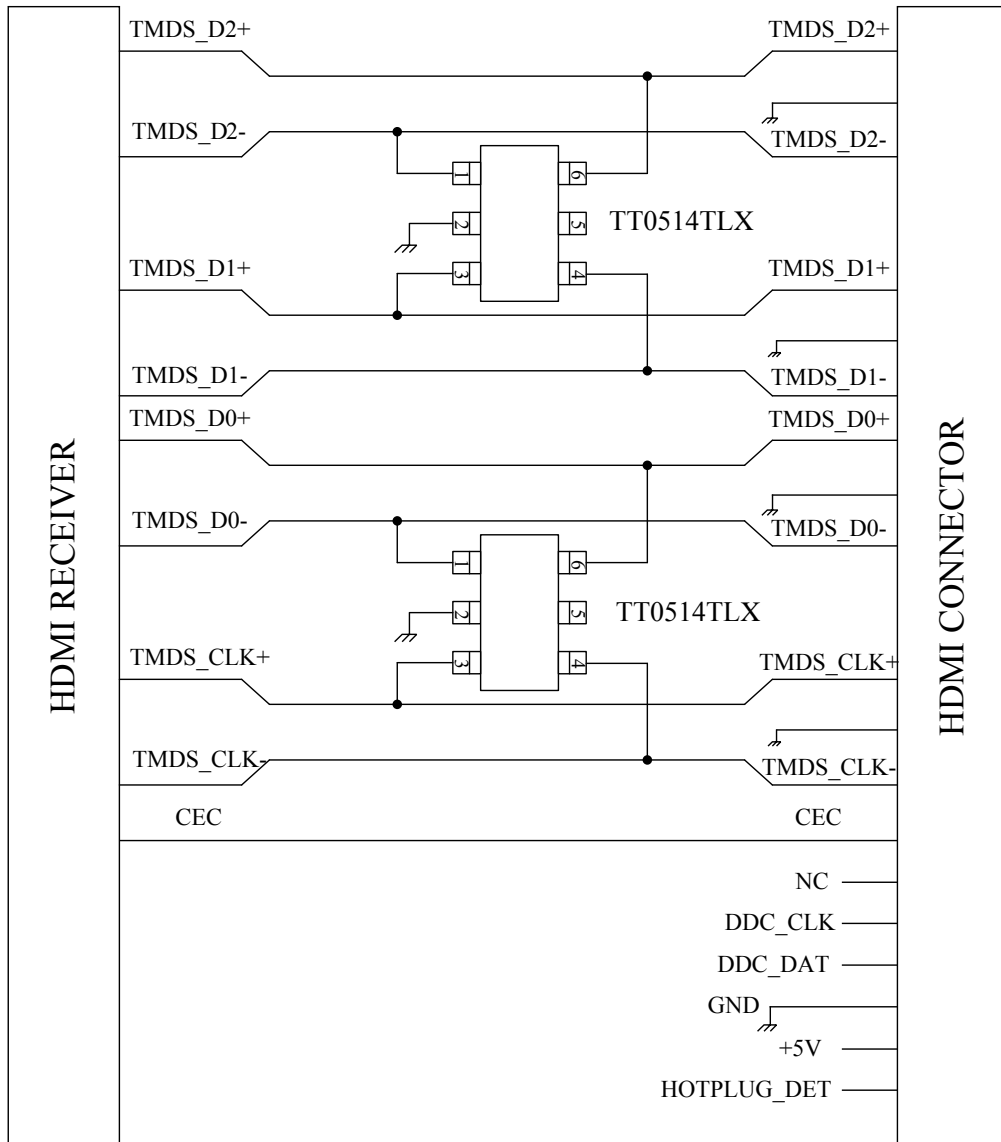

Layout Top View for HDMI Interface with TT0514TL

## Package Outline

□ SOT23-6L package

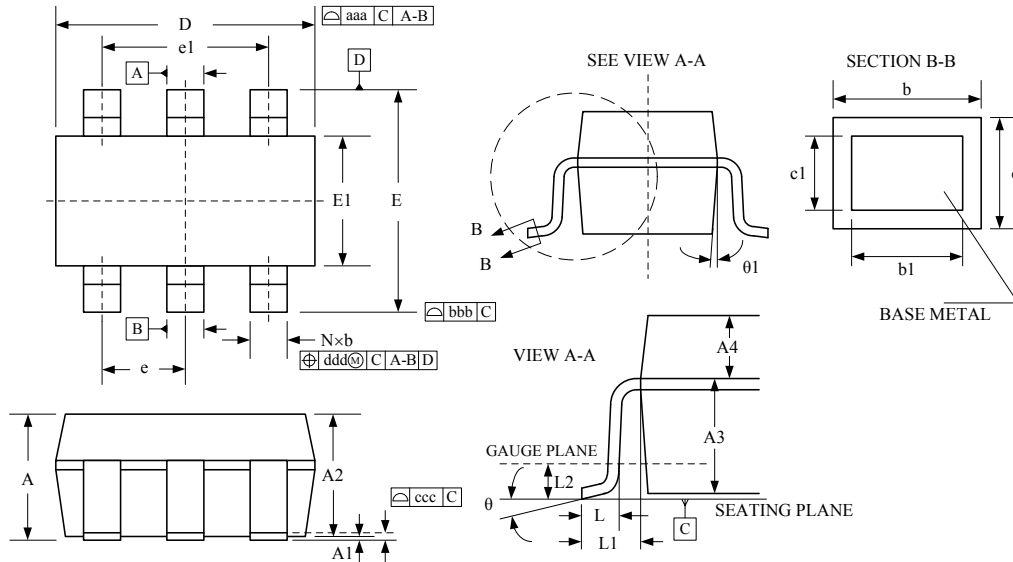

Package Dimensions (Controlling dimensions are in millimeters)

Symbol	Dimensions (mm)			Dimensions (Inches)		
	Minimum	Typical	Maximum	Minimum	Typical	Maximum
A	—	—	1.450	—	—	0.057
A1	0.000	—	0.150	0.000	—	0.006
A2	0.900	1.200	1.300	0.035	0.047	0.012
A3	0.637	0.787	0.837	0.025	0.031	0.033
A4	0.263	0.413	0.463	0.010	0.016	0.018
b	0.300	—	0.500	0.012	—	0.020
b1	0.300	0.400	0.450	0.012	0.016	0.018
c	0.080	—	0.220	0.003	—	0.009
c1	0.080	0.130	0.200	0.003	0.005	0.008
D	2.820	2.90	3.020	0.111	0.114	0.119
e	0.90	0.95	1.00	0.035	0.037	0.039
e1	1.80	1.90	2.00	0.035	0.037	0.039
E	2.65	2.80	2.95	0.104	0.110	0.116
E1	1.50	1.60	1.70	0.059	0.063	0.067
L	0.300	0.450	0.600	0.012	0.018	0.024
L1	0.600 REF			0.024 REF		
L2	0.250 BSC			0.010 BSC		
θ	0°	4°	8°	0°	4°	8°
θ1	5°	10°	15°	5°	10°	15°
aaa	0.150			0.006		
bbb	0.200			0.008		
ccc	0.100			0.004		
ddd	0.100			0.004		

### Tape and Reel Specification

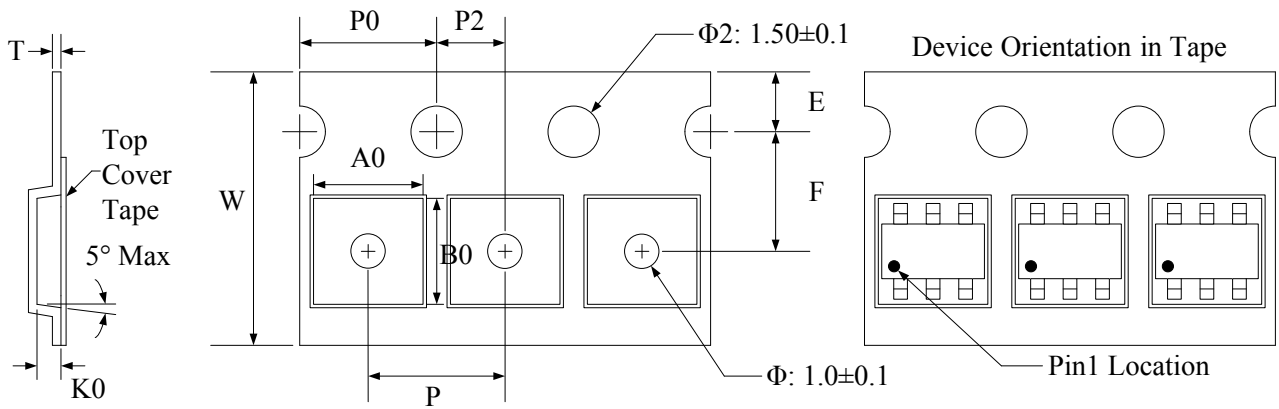

Symbol	W	A0	B0	K0	E	F	P	P0	P2	T
Dimensions (mm)	8.00+0.3 -0.1	3.23±0.05	3.17±0.05	1.37±0.05	1.75±0.1	3.5±0.05	4.0±0.1	4.0±0.1	2.0±0.05	0.25±0.02

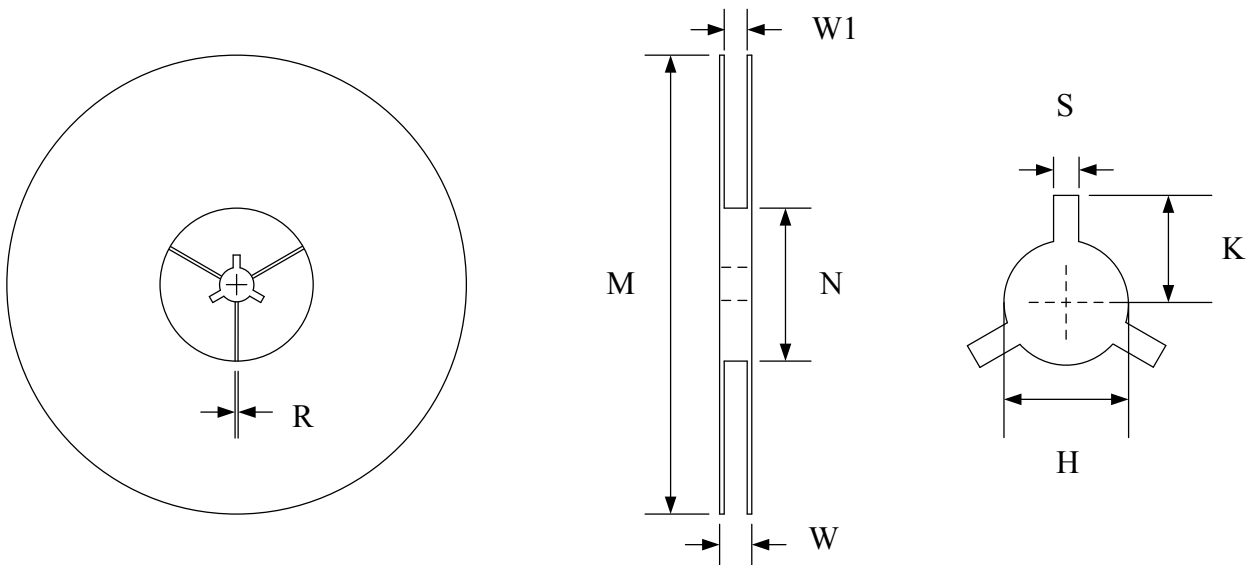

Symbol	Reel Size	M	N	W	W1	H	S	K	R
Dimensions (mm)	$\Phi 178$	178.0±1.0	60.0±1.0	11.5±0.5	9.0±0.5	13.0±0.5	2.0±0.1	11.0±0.2	1.0±0.05

### Marking Codes

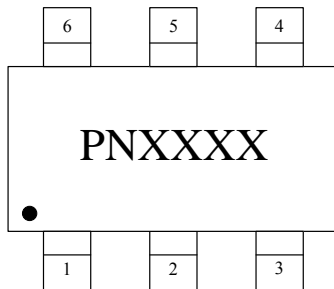

**Note:**

- (1) PN is “16” or “6U”, and is part number.
- (2) “XXXX” is the internal code, 3-4 characters.

### Ordering Information

Part Number	Working Voltage	Quantity Per Reel	Reel Size
TT0514TLX	5V	3,000	7 Inch

### Footprint: SOT23-6L

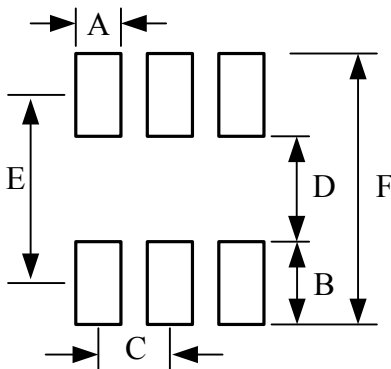

Symbol	Dimensions	
	Millimeters	Inches
A	0.60	0.024
B	1.10	0.043
C	0.95	0.037
D	1.40	0.055
E	2.50	0.098
F	3.60	0.141