

P.C.B LAYOUT

H=8.0 mm

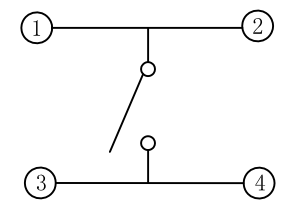

SCHEMATIC

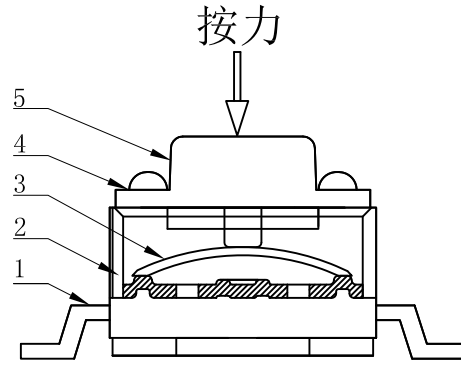
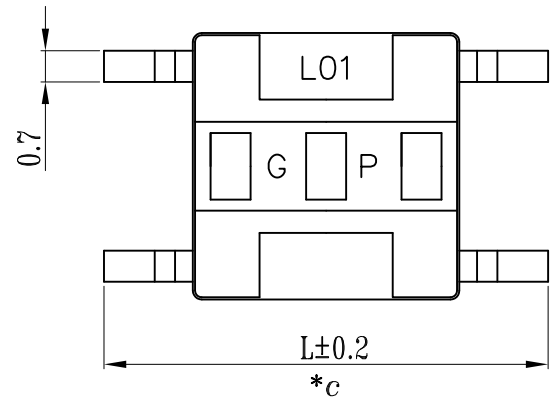

SPECIFICATION

1. Rating : DC12V 50mA.
 2. Contact resistance: ≤100mΩ.
 3. Insulation resistance: ≥100MΩ (DC100V).
 4. Withstanding voltage: 250VAC .
 5. Operating Force: 200±100gf.
 6. Travel: 0.25±0.1mm.
 7. life test: 100,000 cycles.
 8. Operation temperature range: -25℃~85℃.
 9. Sign "*" is importance dimension.
- TEL: 0769-82310510-867

脚距 L
8.0 mm
8.8 mm
9.8 mm

				TOLERANCE UNLESS SPECIFIED							
				<1.5: ±0.1mm	ANGULAR						
				>1.5~5.0: ±0.25mm	±1°	NO	DATE	REVISIONS		BY	APPD
				>5.0: ±0.3mm							
5	KNOB	PA9T	1	BLACK/RED	TITLE: TACT SWITCH		UNIT : MM	ROHS COMPLIANT	DWN		
4	COVER	BRASS/SUS	1	Sn-Plating	MODEL: TC-06104-080E		SCALE: 1:1		CHK'D		
3	CONTACT	SUS	1	Ag-Plated	 DONGGUANG HAOYU ELECTRONICS CO., LTD 皓宇 HOOYA 东莞市弘皓电子有限公司		APPD		PRO.AGL:   REV :AO		
2	CASE	PA9T	1	BLACK							
1	TERMINAL	BRASS	1	Ag-Plated							
NO.	PART NAME	MATERIAL	QTY	FINISHING							