



## Features

- ❑ Transient protection for high-speed data lines
  - IEC 61000-4-2 (ESD) ±25kV (Air)
  - ±17kV (Contact)
  - IEC 61000-4-4 (EFT) 40A (5/50 ns)
  - Cable Discharge Event (CDE)
- ❑ Protects four data lines
- ❑ Low capacitance: 0.3pF Typical (I/O-I/O)
- ❑ Low leakage current: 0.1µA @ V<sub>RWM</sub> (Typical)
- ❑ Low clamping voltage
- ❑ Each I/O pin can withstand over 1000 ESD strikes for ±8kV contact discharge
- ❑ Green Part

## Description

TT0535TJX is a low capacitance Transient Voltage Suppressor (TVS) designed to provide electrostatic discharge (ESD) protection for high-speed data interfaces. With typical capacitance of 0.6pF only, TT0535TJX is designed to protect parasitic-sensitive systems against over-voltage and over-current transient events. It complies with IEC 61000-4-2 (ESD), Level 4 (±15kV air, ±8kV contact discharge), IEC 61000-4-4 (electrical fast transient - EFT) (40A, 5/50 ns), very fast charged device model (CDM) ESD and cable discharge event (CDE), etc.

TT0535TJX uses small SOT363 package. Each TT0535TJX device can protect four high-speed data lines. The combined features of low capacitance, small size and high ESD robustness make ideal for TT0535TJX high-speed data ports and high-frequency lines (e.g., HDMI & DVI) applications. The low clamping voltage of the guarantees TT0535TJX a minimum stress on the protected IC.

## Applications

- ❑ Video Graphics Cards
- ❑ Desktops, Servers and Notebooks
- ❑ IEEE 1394 Ports
- ❑ USB2.0 Power and Data Line Protection
- ❑ Display Ports
- ❑ SIM Ports

## Mechanical Characteristics

- ❑ SOT363 package
- ❑ Flammability Rating: UL 94V-0
- ❑ Marking: Part number
- ❑ Packaging: Tape and Reel

## Circuit Diagram

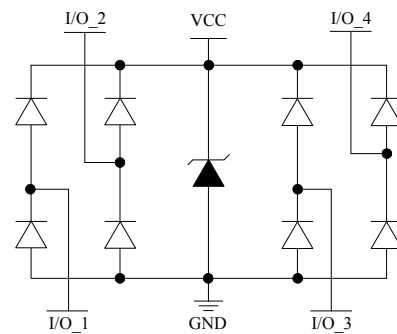

## Pin Configuration

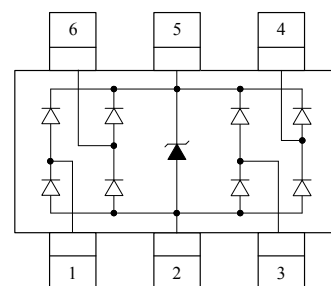

SOT 363  
(Top View)



### Absolute Maximum Rating

Symbol	Parameter	Value	Units
$I_{PP}$	Peak Pulse Current( $t_p=8/20\mu s$ ) (I/O-GND)	5.0	A
$V_{ESD}$	ESD per IEC 61000-4-2(Air) ESD per IEC 61000-4-2 (Contact)	$\pm 25$ $\pm 17$	kV
$T_{OPT}$	Operating Temperature	-55/+125	°C
$T_{STG}$	Storage Temperature	-55/+150	°C

### Electrical Characteristics (T = 25°C)

Symbol	Parameter
$V_{RWM}$	Nominal Reverse Working Voltage
$I_R$	Reverse Leakage Current @ $V_{RWM}$
$V_{BR}$	Reverse Breakdown Voltage @ $I_T$
$I_T$	Test Current for Reverse Breakdown
$V_C$	Clamping Voltage @ $I_{pp}$
$I_{pp}$	Maximum Peak Pulse Current
$C_{ESD}$	Parasitic Capacitance
$V_R$	Reverse Voltage
f	Small Signal Frequency

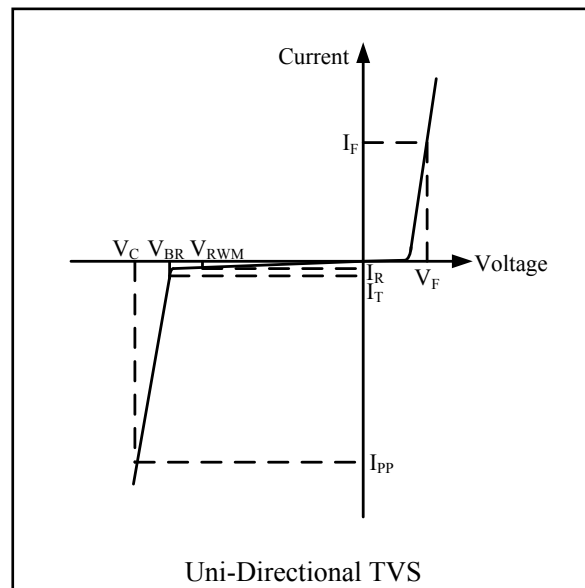

Symbol	Test Condition	Minimum	Typical	Maximum	Units
$V_{RWM}$				5.0	V
$I_R$	$V_{RWM} = 5V, T = 25^\circ C$ Between I/O and GND, Between VCC and GND		0.1	1.0	$\mu A$
$V_{BR}$	$I_T = 1mA$ Between I/O and GND, Between VCC and GND	6.0		9.0	V
$V_C$	$I_{pp} = 5A, t_p = 8/20\mu s$ Between I/O and GND			12.0	V
$V_C$	$I_{pp} = 10A, t_p = 8/20\mu s$ Between VCC and GND			12.0	V
$C_{ESD}$	$V_R = 0V, f = 1MHz$ Between VCC and GND			150	pF
$C_{ESD}$	$V_R = 0V, f = 1MHz$ Between I/O and GND		0.6	0.8	pF
$C_{ESD}$	$V_R = 0V, f = 1MHz$ Between I/O and I/O		0.3	0.4	pF



#### TLP Measurement of I/O to GND

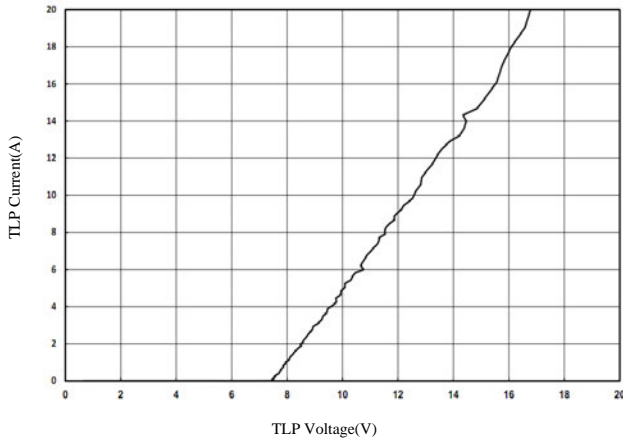

#### Insertion Loss S21 of I/O to GND

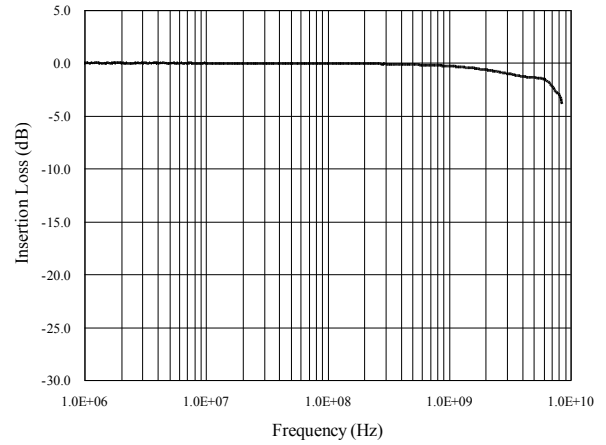

#### Capacitance vs. Voltage of I/O to GND (f = 1MHz)

Capacitance vs. Reverse Voltage

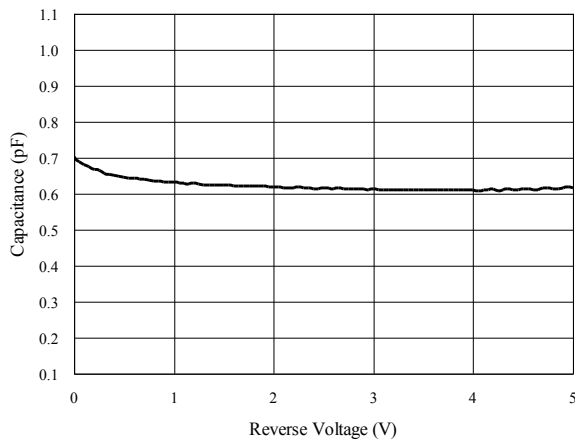

Normalized Capacitance vs. Reverse Voltage

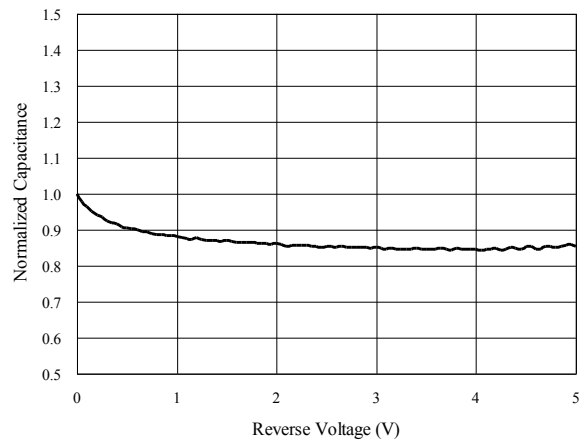

#### ESD Clamping of I/O to GND (+8kV Contact per IEC 61000-4-2)

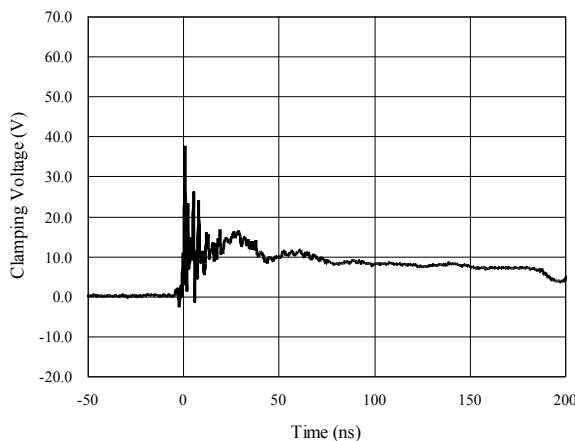

#### ESD Clamping of I/O to GND (-8kV Contact per IEC 61000-4-2)

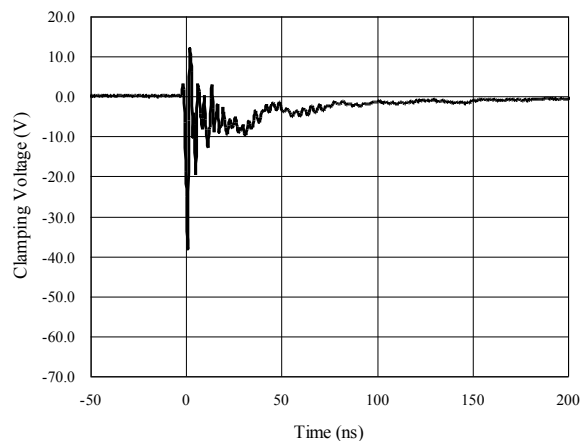



### Typical Application

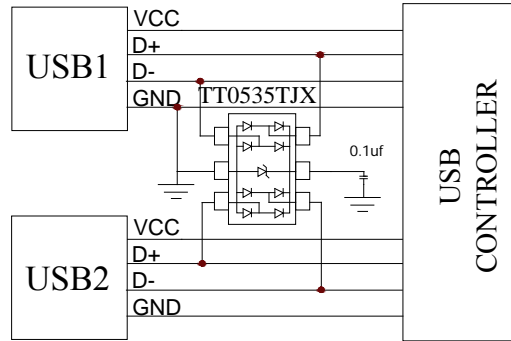

DUAL USB PROTECTION FOR ESD

### ESD protection for USB port

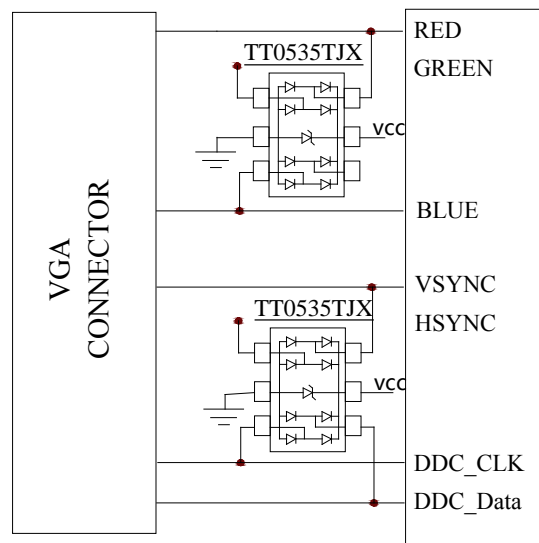

ESD protection for VGA port



Package Outline

(Units: mm)

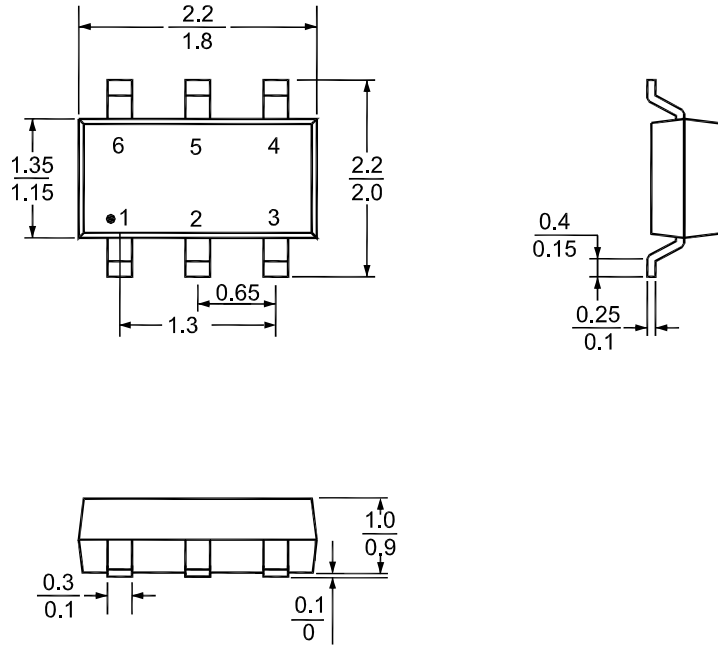

Recommended Soldering Footprint

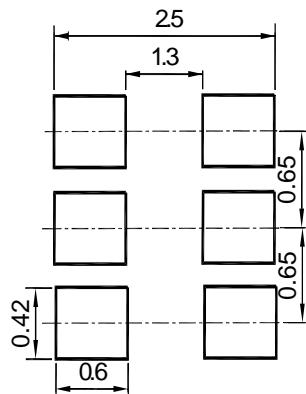

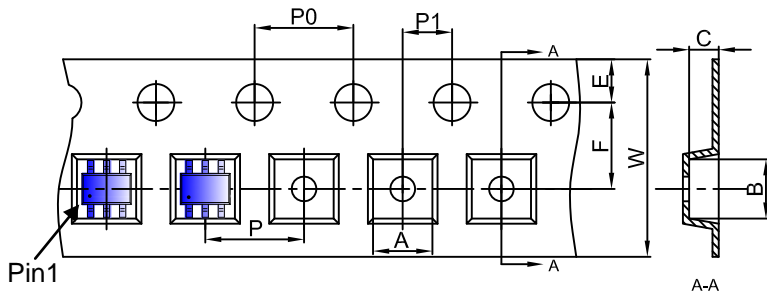
**SOT-363 Embossed Carrier Tape**

Dimensions are in millimeter										
Pkg type	A	B	C	d	E	F	P0	P	P1	W
SOT-363	2.25	2.55	1.20	Ø1.50	1.75	3.50	4.00	4.00	2.00	8.00

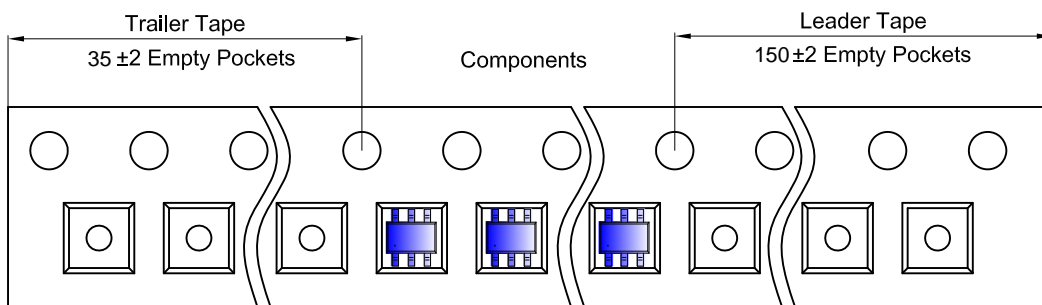
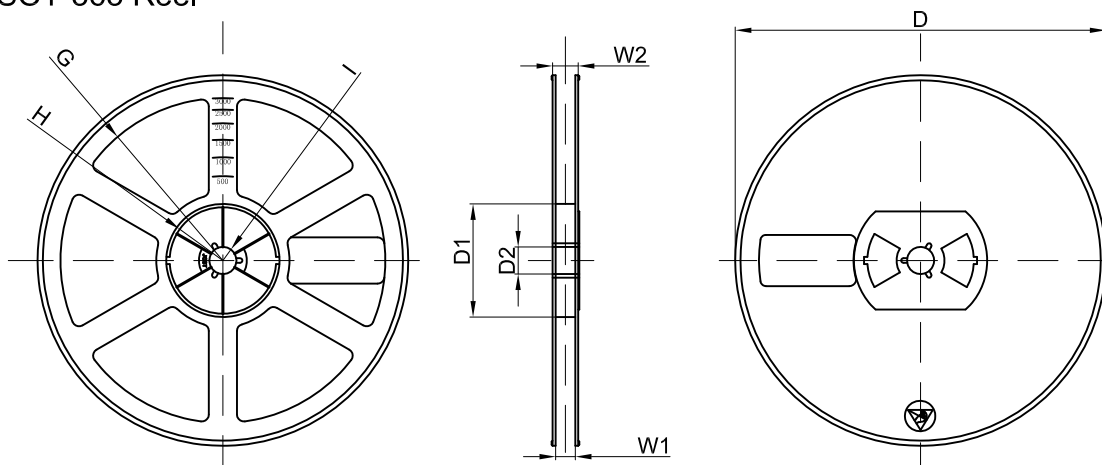
**SOT-363 Tape Leader and Trailer**

**SOT-363 Reel**

Dimensions are in millimeter								
Reel Option	D	D1	D2	G	H	I	W1	W2
7" Dia	Ø178.00	54.40	13.00	R78.00	R25.60	R6.50	9.50	12.30

REEL	Reel Size	Box	Box Size(mm)	Carton	Carton Size(mm)	G.W.(kg)
3000 pcs	7 inch	30,000 pcs	195x128x190	240,000 pcs	525x205x400	

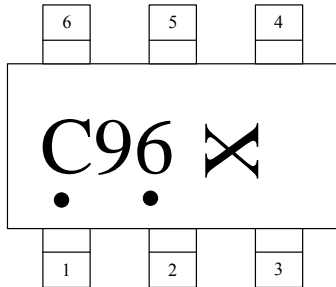
### Marking Codes



**Note:**

- (1) “C96” is part number, fixed.
- (2) X is internal code
- (3) A dot under the C and 6

### Ordering Information

Part Number	Working Voltage	Quantity Per Reel	Reel Size
TT0535TJX	5V	3,000	7 Inch

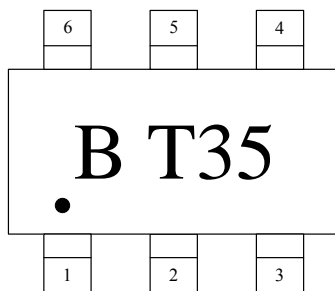

**Note:**

- (1) “B T35” is part number, fixed.