



# MAX485ESA (LX) Low-Power 10Mbps Full Fail-Safe RS-485 Transceiver

## Product Specification

### Specification Revision History:

Version	Date	Description
2022-05-A1	2022-05	New



## 1、General Description

The MAX485ESA is 3V~5.5V powered transceiver that meets the RS-485 standards for balanced communication. It features the larger output voltage and higher data rate up to 10Mbps required by high speed PROFIBUS applications.

This transceiver delivers at least a 2.1V differential output voltage on 5V supply condition, into the RS-485 required 54Ω load, for better noise immunity, or to allow up to three 120Ω terminations in “star” topologies, at the exceptional 10Mbps data rate. This device has very low bus currents so that presents a true “1/8 unit load” to the RS-485 bus. This allows up to 256 transceivers on the network without using repeaters.

Receiver (Rx) inputs feature a “Full Fail-Safe” design, which ensures a logic high Rx output if Rx inputs are floating, shorted, or on a terminated but undriven bus.

### Features:

- Wide supply voltage 3V to 5.5V
- Hot plug circuitry-Tx and Rx outputs remain three-state during power-up/power-down
- High Data Rate: 10Mbps At 5V Supply
- Full fail-safe (open, short, terminated) receivers
- Up to 256 nodes on a bus (1/8 unit load)
- Bus-Pin Protection: ±15kV HBM protection
- Specified from -40°C to +85°C
- Packaging information: SOP8/MSOP8/DFN8

### Ordering Information:

#### Reel packing specifications:

Part number	Packaging form	Marking code	Reel quantity	Boxed reel quantity	Notes
MAX485ESA(LX)	SOP8	MAX485ESA	2500PCS/reel	5000PCS/box	Dimensions of plastic enclosure: 4.9mm×3.9mm Pin spacing:1.27mm
MAX485ESA(LX)	MSOP8	MAX485ESA	5000PCS/reel	10000PCS/box	Dimensions of plastic enclosure: 3.0mm×3.0mm Pin spacing:0.65mm

Note: If the physical information is inconsistent with the ordering information, please refer to the actual product.



## 2、Block Diagram And Pin Description

### 2.1、Pin Configurations

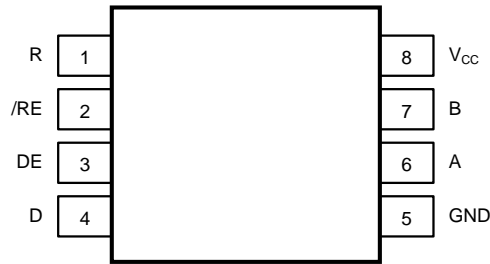

### 2.2、Pin Description

Pin No.	Pin Name	I/O	Description
1	R	digital output	receiver output
2	/RE	digital input	receiver output enable
3	DE	digital input	driver output enable
4	D	digital input	driver input
5	GND	ground	ground
6	A	bus input/output	noninverting receiver input A and noninverting driver output A
7	B	bus input/output	inverting receiver input A and inverting driver output A
8	V <sub>CC</sub>	power	power supply

### 2.3、Function Table

#### 2.3.1、Driver Function Table

Input	Enable	Outputs		Description
		A	B	
<b>Normal Mode</b>				
H	H	H	L	actively drives bus High
L	H	L	H	actively drives bus Low
X	L	Z	Z	driver disabled
X	open	Z	Z	driver disabled by default
open	H	H	L	actively drives bus High by default

#### 2.3.2、Receiver Function Table

Differential Input	Enable	Outputs	Description
V <sub>ID</sub> =V <sub>A</sub> -V <sub>B</sub>	/RE	R	
<b>Normal Mode</b>			
V <sub>IT+</sub> <V <sub>ID</sub>	L	H	receive valid bus High
V <sub>IT-</sub> <V <sub>ID</sub> <V <sub>IT+</sub>	L	-	indeterminate bus state
V <sub>ID</sub> <V <sub>IT-</sub>	L	L	receive valid bus Low
X	H	Z	receiver disabled
X	open	Z	receiver disabled by default
open, short, idle bus	L	H	fail-safe high output



### 3、Electrical Parameter

#### 3.1、Absolute Maximum Ratings

( $T_{amb}=25^{\circ}\text{C}$ , all voltage referenced to GND, unless otherwise specified)

Characteristic	Symbol	Conditions	Value	Unit
supply voltage	$V_{CC}$	-	-0.3 to +7	V
input voltage	$V_I$	D, DE, /RE	-0.3 to $V_{CC}+0.3$	V
Input/output voltage	$V_{IO}$	A, B	-15 to +15	V
		A, B (transient pulse through 100 $\Omega$ )	$\pm 100$	V
		R	-0.3 to $V_{CC}+0.3$	V
short circuit duration	-	A, B	continuous	-

#### 3.2、Recommended Operating Conditions

Characteristic	Symbol	Conditions	Value	Unit
supply voltage	$V_{CC}$	-	3 to 5.5	V
bus pin common mode voltage	$V_{CM}$	-	-7 to 12	V
High-level input voltage	$V_{IH}$	driver, driver enable, and receiver enable inputs	2 to $V_{CC}$	V
Low-level input voltage	$V_{IL}$	driver, driver enable, and receiver enable inputs	0 to 0.8	V
differential input voltage	$V_{ID}$	-	-7 to 12	V
differential load resistance	$R_L$	-	>54	$\Omega$
operating temperature	$T_{amb}$	-	-40 to 85	$^{\circ}\text{C}$
storage temperature	$T_{stg}$	-	-65 to 150	$^{\circ}\text{C}$

#### 3.3、ESD Rating

HBM Model	Value	Unit
bus pins(A,B)	$\pm 15$	kV
all other pins	$\pm 15$	kV



3.4、Electrical Characteristics

3.4.1、DC Characteristics

( $T_{amb}=-40$  to  $85^{\circ}C$ ,  $V_{CC}=5V$ , unless otherwise specified)

Parameter	Symbol	Conditions	Min.	Typ.	Max.	Unit	
driver differential-output voltage magnitude	$ V_{OD} $	$R_L=60\Omega@VA\&VB(-7\sim 12V)$ $V_{CC}=4.5$ to $5.5V$	Figure 1B	2.1	3.5	-	V
		$R_L=60\Omega@VA\&VB(-7\sim 12V)$ $V_{CC}=3.0$ to $3.6V$		1.5	2.2	-	V
		$R_L=54\Omega, V_{CC}=5V$	Figure 1A	2	3.6	-	V
		$R_L=54\Omega, V_{CC}=3V$		1.5	1.9	-	V
		$R_L=100\Omega, V_{CC}=5V$		2.7	4.0	-	V
		$R_L=100\Omega, V_{CC}=3V$		2	2.3	-	V
change in magnitude of driver differential-output voltage	$\Delta V_{OD} $	$R_L=54\Omega, V_{CC}=5V, C_L=50pF$	Figure 1A	-50	2	50	mV
steady-stage common-mode output voltage	$V_{OC(SS)}$			1	$V_{CC}/2$	3	V
change in differential driver common-mode output voltage	$\Delta V_{OC}$	center of two $27\Omega$ load resistors	Figure 1A	-	50	-	mV
peak-to-peak driver common-mode output voltage	$V_{OC(PP)}$			-	500	-	mV
differential output capacitance	$C_{OD}$	-	-	8	-	pF	
positive-going receiver differential-input voltage threshold	$V_{IT+}$	$VA/VB$ : from $-7\sim 12V$	-	-120	-40	mV	
negative-going receiver differential-input voltage threshold	$V_{IT-}$	$VA/VB$ : from $-7\sim 12V$	-220	-170	-	mV	
receiver differential-input voltage threshold hysteresis ( $V_{IT+}-V_{IT-}$ )	$V_{HYS}$	-	-	50	-	mV	
logic Input High Voltage	$V_{IH}$	DI, DE, /RE	2	-	-	V	
logic Input Low Voltage	$V_{IL}$	DI, DE, /RE	-	-	0.8	V	
receiver high-level output voltage	$V_{OH}$	$I_{OH}=-8mA$	3	4.6	-	V	
receiver low-level output voltage	$V_{OL}$	$I_{OL}=8mA$	-	-	0.4	V	
driver input, driver enable	$I_i$	DI, DE, /RE	-5	-	5	$\mu A$	
receiver high-Z output current	$I_{OZ}$	$V_O=0/V_{CC}, /RE=V_{CC}$	-1	-	1	$\mu A$	
driver short-circuit output current	$ I_{OS} $	$ I_{OS} $ with $VA/VB$ from $-7$ to $12V$	-250	110	250	mA	
		bus pin A,B short current	-	-	150	mA	
bus input current(driver disabled)	$I_{IN}$	$V_{CC}=4.5$ to $5.5$ or $V_{CC}=0, DE$ at $0V$	$V_I=12V$	-	-	120	$\mu A$
			$V_I=-7V$	-110	-	-	$\mu A$



bus input impedance	$R_A/R_B$	VA=-7V, VB=12V and VA=12V, VB=-7V	96	-	-	K $\Omega$	
supply current (quiescent)	$I_{CC}$	TX, RX enable	DE= $V_{CC}$ , /RE=GND, no load;	-	1.9	2.2	mA
		TX enable, RX disable	DE= $V_{CC}$ , /RE= $V_{CC}$ , no load;	-	0.47	0.6	
		TX disable, RX enable	DE=GND, /RE=GND, no load;	-	1.7	2.0	
		TX disable, RX disable	DE=GND, /RE= $V_{CC}$ , no load;	-	-	<0.001	

### 3.4.2、AC Characteristics

Parameter	Symbol	Conditions	Min.	Typ.	Max.	Unit	
<b>Driver</b>							
maximum data rate	$f_{MAX}$	$V_{OD} \geq \pm 1.5V$ , $R_L = 54\Omega$ , $C_L = 100pF$ ; (Figure 4)	-	-	10	Mbps	
driver differential-output rise and fall times	$t_r, t_f$	$R_L = 54\Omega$ , $C_L = 50pF$	Figure 2	-	5	-	ns
driver propagation delay	$t_{PHL}, t_{PLH}$			-	15	30	ns
$ t_{PHL} - t_{PLH} $	$t_{SK(P)}$			-	-	20	ns
driver disable time	$t_{PHZ}$	$C_L = 15pF$	Figure 3	-	17	50	ns
	$t_{PLZ}$			-	20	50	ns
driver enable time	$t_{PZH}$	RX enable	Figure 3	-	36	45	ns
		RX disable		-	2400	3200	ns
	$t_{PZL}$	RX enable		-	21	45	ns
		RX disable		-	2400	3200	ns
<b>Receiver</b>							
receiver output rise and fall times	$t_r, t_f$	$C_L = 15pF$	Figure 5	-	9	-	ns
receiver propagation delay time	$t_{PHL}, t_{PLH}$			-	28	50	ns
receiver pulse skew, $ t_{PHL} - t_{PLH} $	$t_{SK(P)}$			-	-	15	ns
receiver disable time	$t_{PHZ}$	-		-	30	60	ns
	$t_{PLZ}$			-	27	60	
receiver enable time	$t_{PZH}$	TX enable		-	67	-	ns
		TX disable		-	2500	3200	ns
	$t_{PZL}$	TX enable		-	24	35	ns
		TX disable		-	2400	3200	ns

## 4、Testing Circuit

### 4.1、DC Testing Circuit

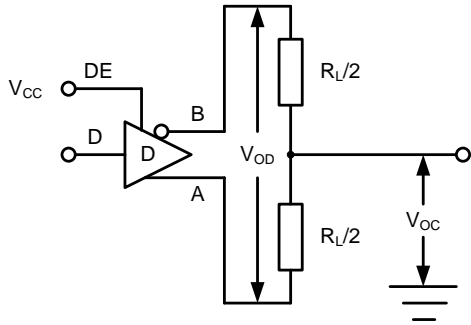

Figure 1A.  $V_{OD}$  and  $V_{OC}$

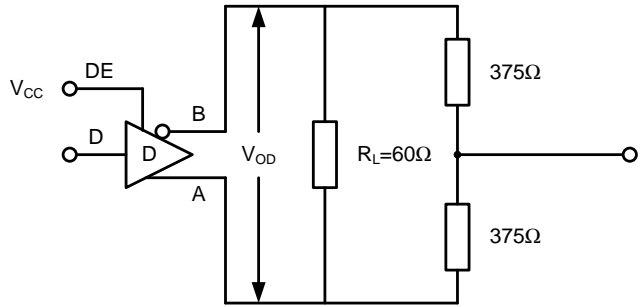

Figure 1B.  $V_{OD}$  with common mode load

Figure 1. DC driver test circuits

### 4.2、AC Testing Circuit

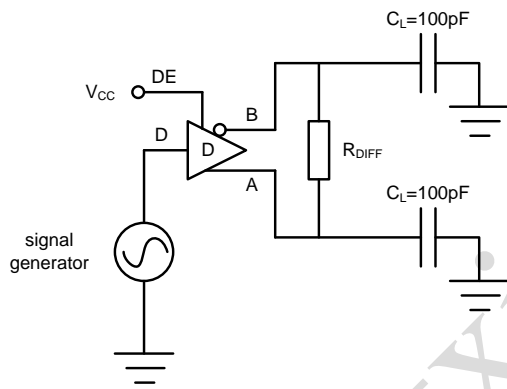

Figure 2A. test circuit

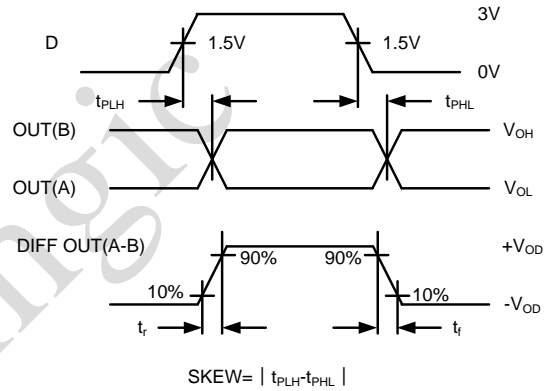

Figure 2B. measurement points

Figure 2. driver propagation delay and differential transition times

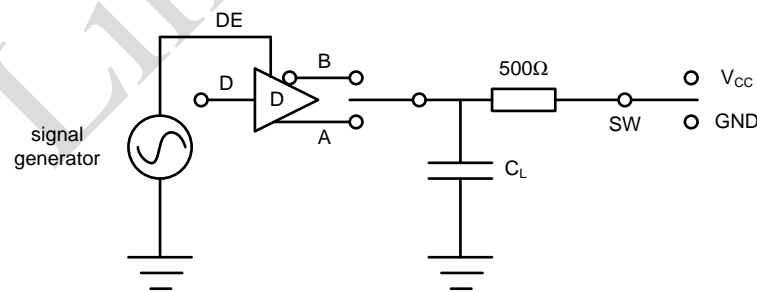

Figure 3A. test circuit

Parameter	Output	/RE	D	SW	$C_L$ (pF)
$t_{PHZ}$	A/B	X	1/0	GND	15
$t_{PLZ}$	A/B	X	0/1	$V_{CC}$	15
$t_{PZH}$	A/B	0	1/0	GND	100
$t_{PZL}$	A/B	0	0/1	$V_{CC}$	100
$t_{PZH(SHDN)}$	A/B	1	1/0	GND	100
$t_{PZL(SHDN)}$	A/B	1	0/1	$V_{CC}$	100

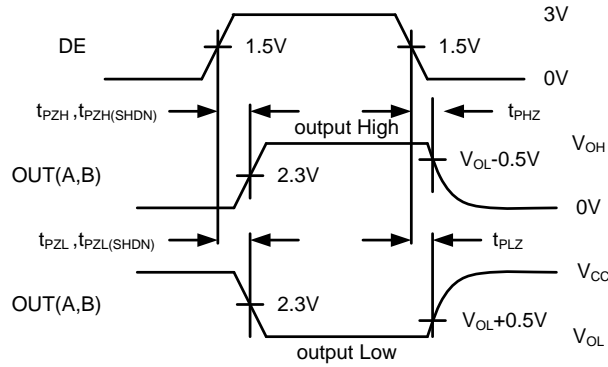

Figure 3B. measurement points  
Figure 3. driver enable and disable times

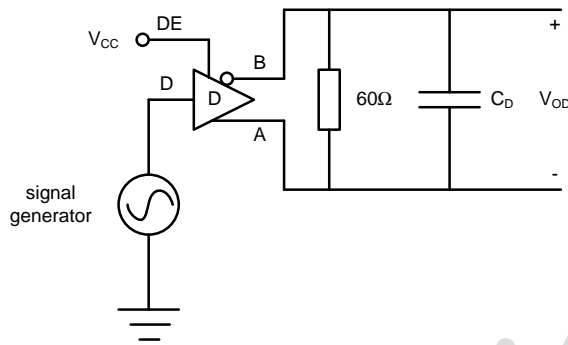

Figure 4A. test circuit

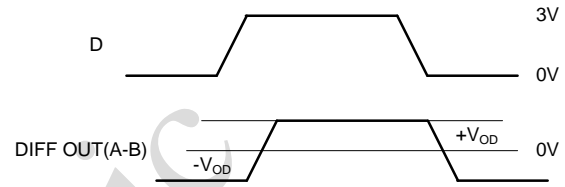

Figure 4B. measurement points

Figure 4. driver data rate

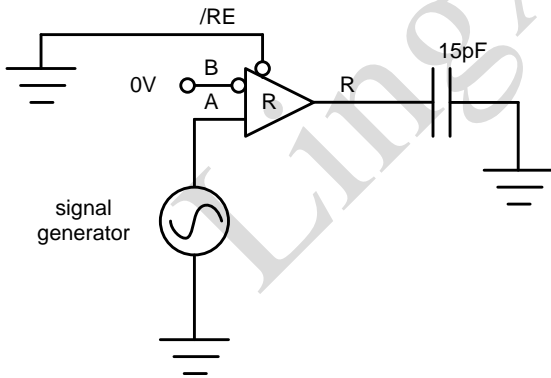

Figure 5A. test circuit

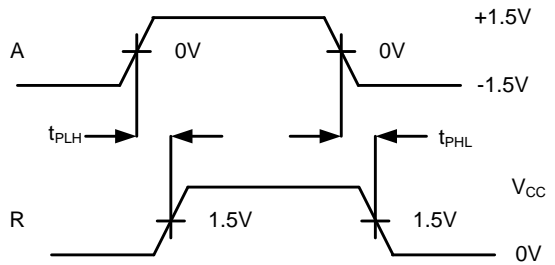
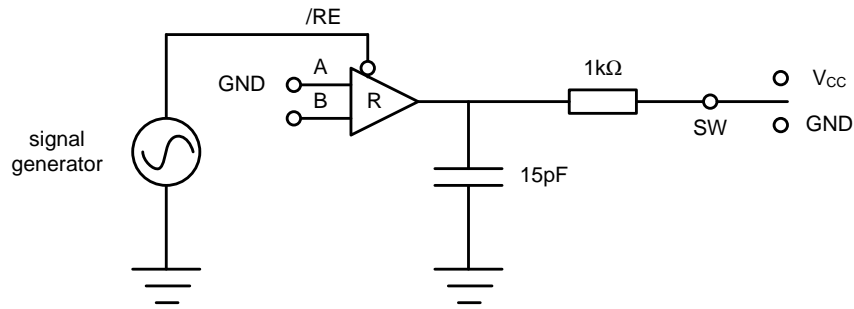

Figure 5B. measurement points

Figure 5. receiver propagation delay and data rate





Parameter	DE	A	SW
$t_{PHZ}$	1	+1.5V	GND
$t_{PLZ}$	1	-1.5V	V <sub>CC</sub>
$t_{PZH}$	1	+1.5V	GND
$t_{PZL}$	1	-1.5V	V <sub>CC</sub>
$t_{PZH(SHDN)}$	0	+1.5V	GND
$t_{PZL(SHDN)}$	0	-1.5V	V <sub>CC</sub>

Figure 6A. test circuit

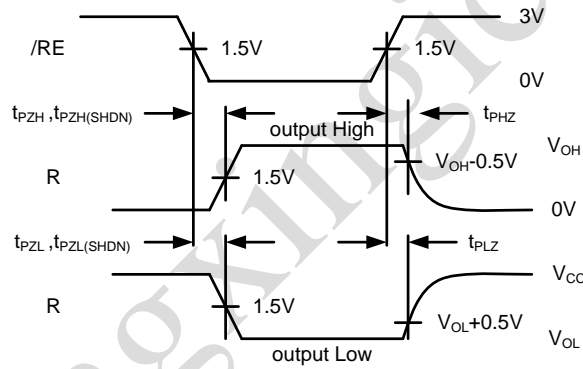

Figure 6B. measurement points

Figure 6. receiver enable and disable times



## 5、Characteristic Curve

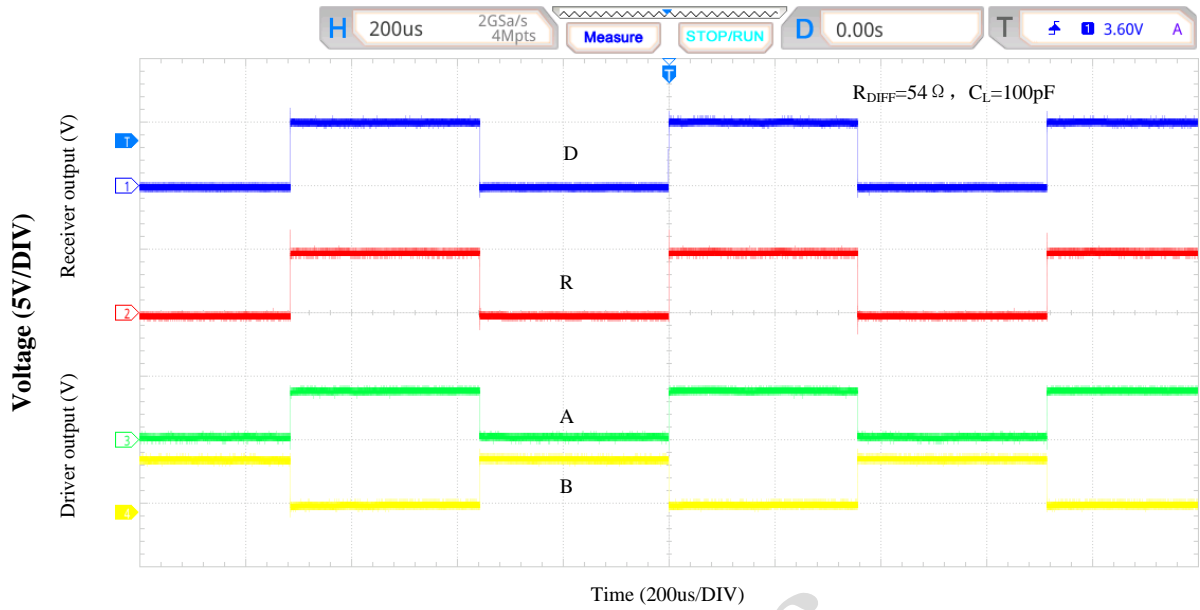

Figure 7. driver and receiver waveforms

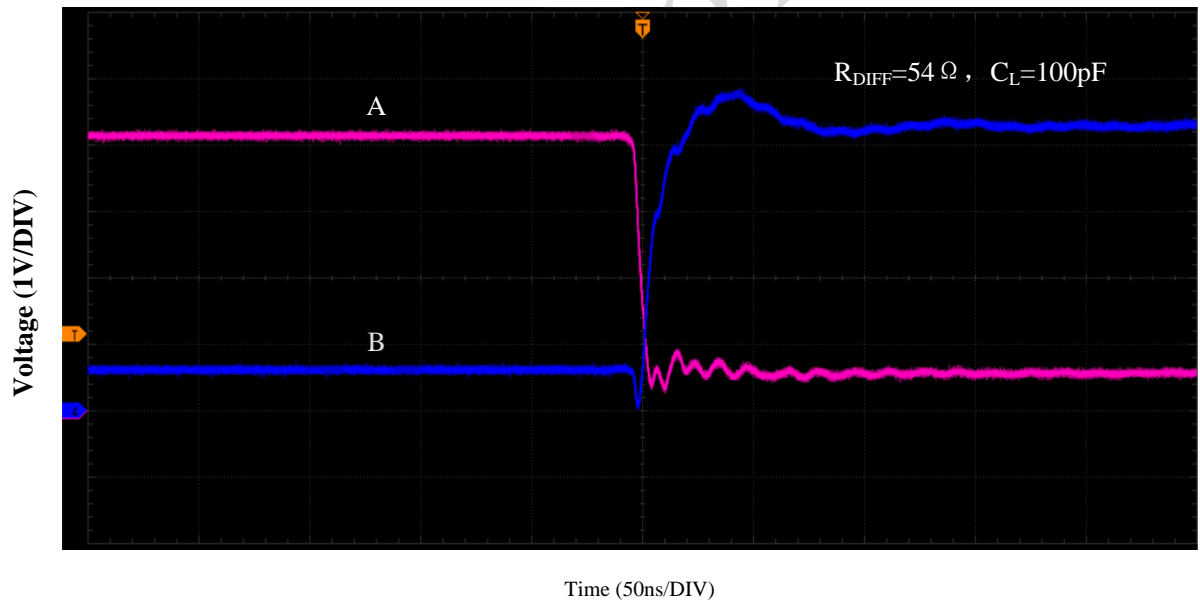

Figure 8. driver waveforms



## 6、 Function Description

RS-485 is intended for network lengths up to 4000', but the maximum system data rate decreases as the transmission length increases. Devices operating at 10Mbps are limited to lengths less than 100'.

Twisted pair is the cable of choice for RS-485 networks. Twisted pair cables tend to pick up noise and other electromagnetically induced voltages as common mode signals, which are effectively rejected by the differential receiver in this IC.

Proper termination is imperative to minimize reflections. In point-to-point, or point-to-multipoint (single driver on bus) networks, the main cable should be terminated in its characteristic impedance (typically 120Ω) at the end farthest from the driver. In multi-receiver applications, stubs connecting receivers to the main cable should be kept as short as possible. Multipoint (multi-driver) systems require that the main cable be terminated in its characteristic impedance at both ends. Stubs connecting a transceiver to the main cable should be kept as short as possible.

The MAX485ESA may also be used at slower data rates over longer cables, but there are some limitations. The Rx is optimized for high speed operation, so its output may glitch if the Rx input differential transition times are too slow. Keeping the transition times below 500ns, which equates to the Tx driving a 1000'(305m) CAT 5 cable, yields excellent performance over the full operating temperature range.

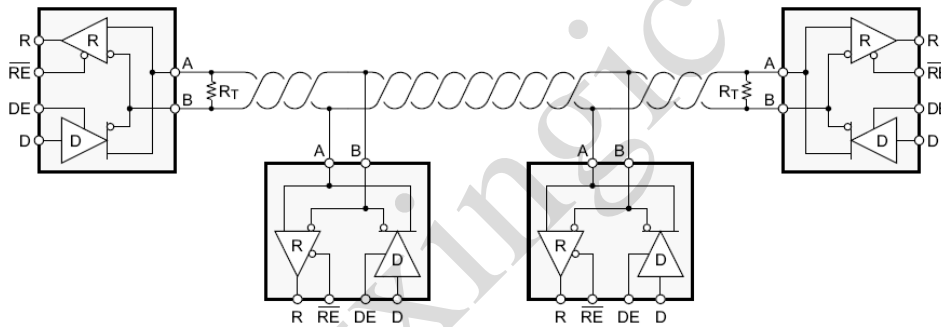

Figure 9. Typical Application

### 6.1、 Receiver (Rx) Features

MAX485ESA utilize a differential input receiver for maximum noise immunity and common mode rejection. Input sensitivity is better than  $\pm 200\text{mV}$ , as required by the RS-485 specifications. Rx outputs feature high drive levels to ease the design of optically coupled isolated interfaces.

Receiver input resistance of 100kΩ is eight times the RS-485 “Unit Load (UL)” requirement of 12kΩ minimum. Thus, these products are known as UL/8 transceivers, and there can be up to 256 of these devices on a network while still complying with the RS-485 loading specification. Rx inputs function with common mode voltages as great as  $\pm 7\text{V}$  outside the power supplies (i.e., +12V and -7V), making them ideal for long networks where induced voltages are a realistic concern.

### 6.2、 Driver (Tx) Features

MAX485ESA driver is a differential output device that delivers at least 2.1V across a 54Ω load (RS-485). The drivers feature low propagation delay skew to maximize bit width, and to minimize EMI, and all drivers are three-stable via the active high DE input.



6.3、 Full Fail-Safe

The receiver includes a “full fail-safe” function that guarantees a high level receiver output if the receiver inputs are unconnected (floating), shorted together, or connected to a terminated bus with all the transmitters disabled. The receiver easily meets the data rates supported by the corresponding driver, and the receiver output is three-stable via the active low /RE input.

6.4、 Hot Plug Function

When a piece of equipment powers up, there is a period of time where the processor or ASIC driving the RS-485 control lines (DE, /RE) is unable to ensure that the RS-485 Tx and Rx outputs are kept disabled. If the equipment is connected to the bus, a driver activating prematurely during power-up may crash the bus. To avoid this scenario, the MAX485ESA devices incorporate a “Hot Plug” function. Circuitry monitoring VCC ensures that, during power-up and power-down, the Tx and Rx outputs remain disabled, regardless of the state of DE and /RE, if VCC is less than ~2.5V. This gives the processor/ASIC a chance to stabilize and drive the RS-485 control lines to the proper states.

6.5、 Detailed Design Procedure

In order to protect bus nodes against high-energy transients, the implementation of external transient protection devices is necessary.

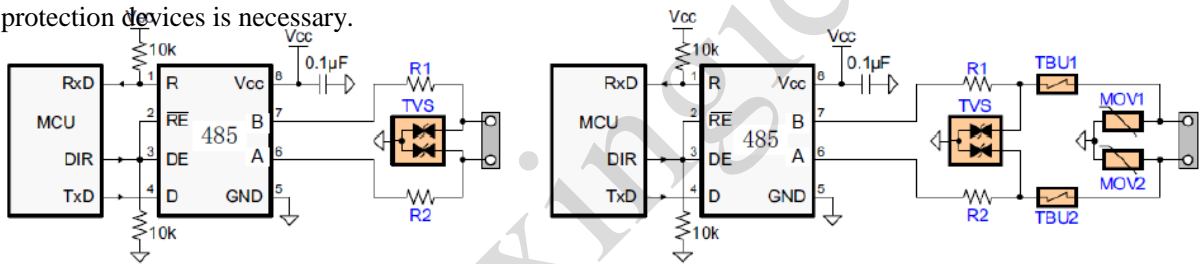

Figure 10. Transient Protections Against ESD, EFT, and Surge Transients

The left circuit shown in Figure 10 provides surge protection of ≥500V transients, while the right protection circuits can withstand surge transients of 5KV. Table 1 shows the associated Bill of Materials.

Table 1. Bill of Materials

Device	Function	Order Number	Manufacturer
485	5-V, 10Mbps RS-485 Transceiver	MAX485ESA	
R1,R2	10-Ω, Pulse-Proof Thick-Film Resistor	CRCW0603010RJNEAHP	Vishay
TVS	Bidirectional 400-W Transient Suppressor	CDSOT23-SM712	Bourns
TBU1,TBU2	Bidirectional	TBU-CA-065-200-WH	Bourns
MOV1,MOV2	200mA Transient Blocking Unit 200-V, Metal- Oxide Varistor	MOV-10D201K	Bourns



## 7、Package Information

### 7.1、SOP8

#### SOP8(SO1R)

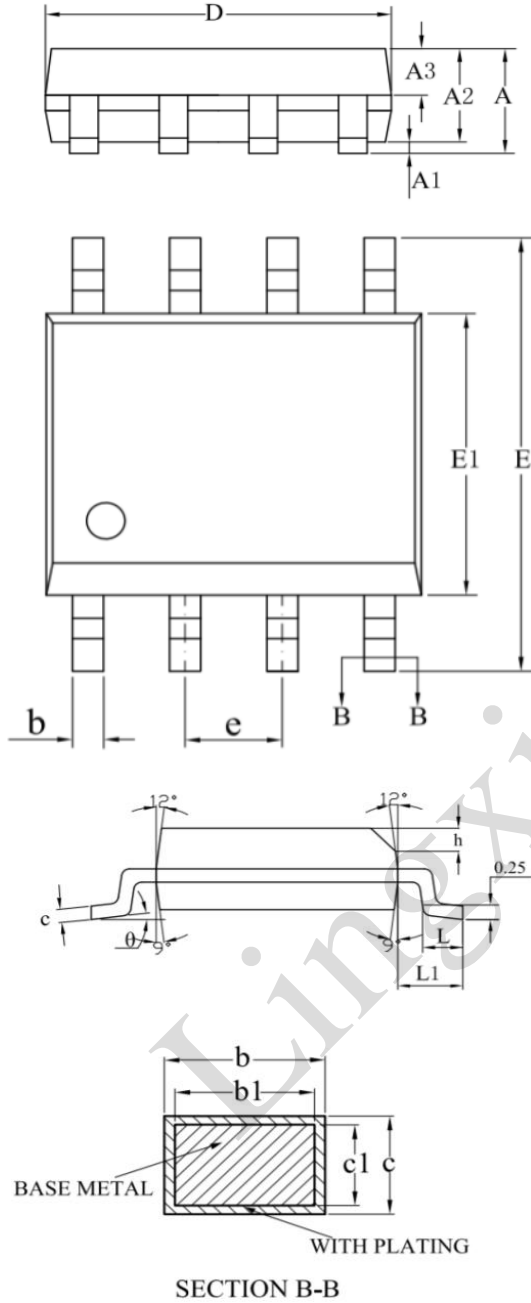

SYMBOL	MILLIMETER		
	MIN	NOM	MAX
A	—	—	1.75
A1	0.10	—	0.225
A2	1.30	1.40	1.50
A3	0.60	0.65	0.70
b	0.39	—	0.47
b1	0.38	0.41	0.44
c	0.20	—	0.24
c1	0.19	0.20	0.21
D	4.80	4.90	5.00
E	5.80	6.00	6.20
E1	3.80	3.90	4.00
e	1.27BSC		
h	0.25	—	0.50
L	0.50	—	0.80
L1	1.05REF		
$\theta$	0	—	$8^\circ$



7.2、MSOP8

MSOP8(VS1R)

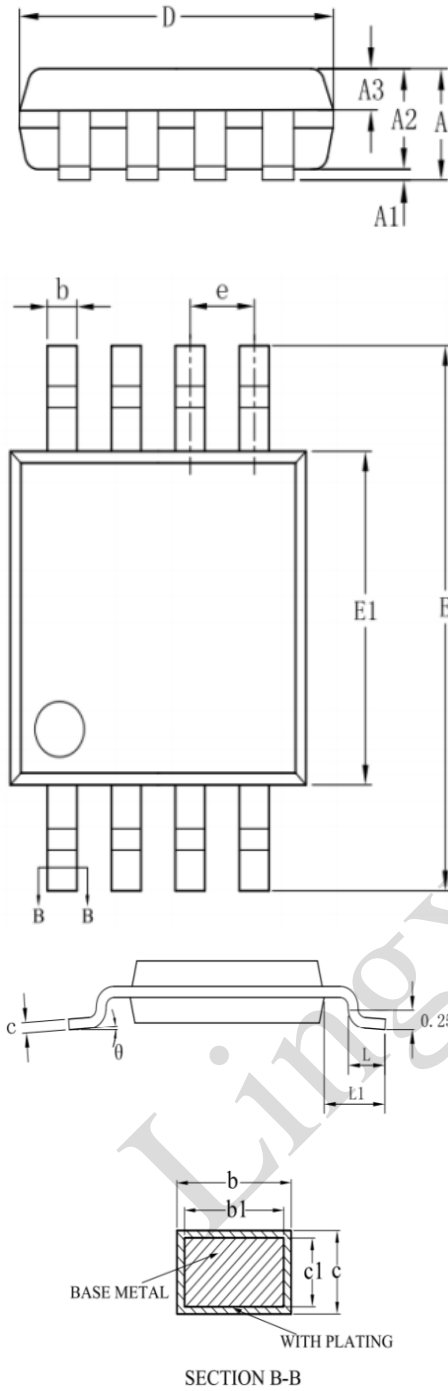

SYMBOL	MILLIMETER		
	MIN	NOM	MAX
A	—	—	1.10
A1	0.05	—	0.15
A2	0.75	0.85	0.95
A3	0.30	0.35	0.40
b	0.28	—	0.36
b1	0.27	0.30	0.33
c	0.15	—	0.19
c1	0.14	0.15	0.16
D	2.90	3.00	3.10
E	4.70	4.90	5.10
E1	2.90	3.00	3.10
e	0.65BSC		
L	0.40	—	0.70
L1	0.95REF		
$\theta$	0	—	8°



7.3、DFN8

DFNWB3X3-8L-F(DF6R)

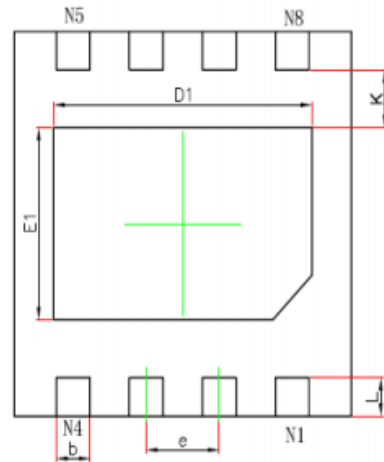
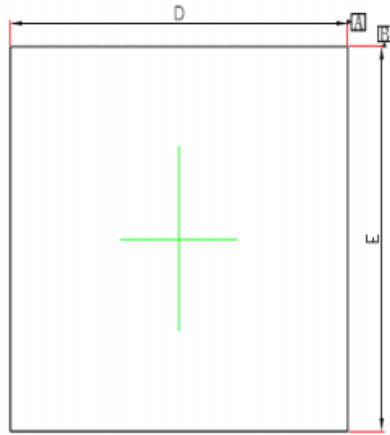

TOP VIEW

BOTTOM VIEW

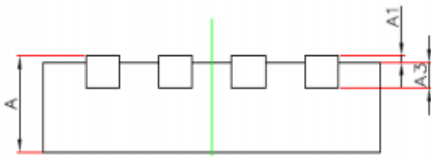

SIDE VIEW

Symbol	Dimensions In Millimeters		Dimensions In Inches	
	Min.	NOM.	Min.	NOM.
A	0.700/0.800	0.800/0.900	0.028/0.031	0.031/0.035
A1	0.000	0.050	0.000	0.002
A3	0.203REF.		0.008REF.	
D	3.000BSC.		0.118BSC.	
E	3.000BSC.		0.118BSC.	
D1	2.200	2.400	0.087	0.094
E1	1.400	1.600	0.055	0.063
k	0.250MIN.		0.010MIN.	
b	0.250	0.350	0.010	0.014
e	0.650TYP.		0.026TYP.	
L	0.224	0.376	0.009	0.015



8、Statements And Notes

8.1、The name and content of Hazardous substances or Elements in the product

Part name	Hazardous substances or Elements									
	Lead and lead compounds	Mercury and mercury compounds	Cadmium and cadmium compounds	Hexavalent chromium compounds	Polybrominated biphenyls	Polybrominated biphenyl ethers	Dibutyl phthalate	Butylbenzyl phthalate	Di-2-ethylhexyl phthalate	Diisobutyl phthalate
Lead frame	○	○	○	○	○	○	○	○	○	○
Plastic resin	○	○	○	○	○	○	○	○	○	○
Chip	○	○	○	○	○	○	○	○	○	○
The lead	○	○	○	○	○	○	○	○	○	○
Plastic sheet installed	○	○	○	○	○	○	○	○	○	○
explanation	<p>○: Indicates that the content of hazardous substances or elements in the detection limit of the following the SJ/T11363-2006 standard.</p> <p>×: Indicates that the content of hazardous substances or elements exceeding the SJ/T11363-2006 Standard limit requirements.</p>									

8.2、Notion

Recommended carefully reading this information before the use of this product;

The information in this document are subject to change without notice;

This information is using to the reference only, the company is not responsible for any loss;

The company is not responsible for the any infringement of the third party patents or other rights of the responsibility.