



产品规格书 PRODUCT SPECIFICATION

产品类型 Description	压电式无源蜂鸣器 Piezoelectric passive buzzer
客户名称 Customer	
客户型号 Customer's Model	
华能型号 HN's Model	HNR-1407 PA7.5
华能料号 HN's Part NO.	
日期 Date	2020-11-07

客户接受 This specification is received:

确认盖章 Acceptance day DATE:

注：若客户认可，请回签此份规格书，谢谢合作。

拟制 Drafted	审核 Checked by	批准 Approved by
冯才林	周萍	张华

TEL:0523-83710666 FAX:0523-83724866

Web:http://www.jshnbuzzer.com

Address: 江苏省泰州市兴化市陈堡镇工业园区



型号 Model No.: HNR-1407 PA7.5

1	额定电压 Rated Voltage (VDC)	5
2	工作电压 Operating Voltage (VDC)	1-30
3	在10cm处测试声压值 Sound Output at 10cm (dB)	≥85 at 4000Hz Square Wave 5Vp-p
4	消耗电流 Current Consumption (mA)	≤10 at 4000Hz Square Wave 5Vp-p
5	共振频率 Resonant Frequency (Hz)	4000 ± 500
6	工作温度 Operating Temperature (°C)	-20 ~ +70
7	储存温度 Storage Temperature (°C)	-30 ~ +80
8	单品重量 Weight (g)	0.85
9	外壳材料 Housing Material	黑色 Black PBT

蜂鸣器焊接方法 Buzzer Soldering process	Soldering Parameter		
	温度 Temp.(°C)	时间 Time(Sec.)	可焊接次数 Times
★波峰焊 Wave soldering	260±5	4~6	2~3
★手工焊 Manual soldering	350±10	2~5	2~3

带★号为推荐的焊接方式 Remark: ★Instance Soldering Process

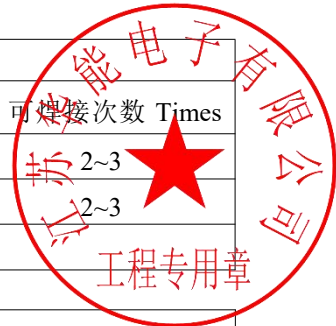

外形尺寸图 (单位: 毫米) DIMENSIONS (UNIT: mm)

未标注公差尺寸按±0.5mm Tolerance: ±0.5mm Except Specified

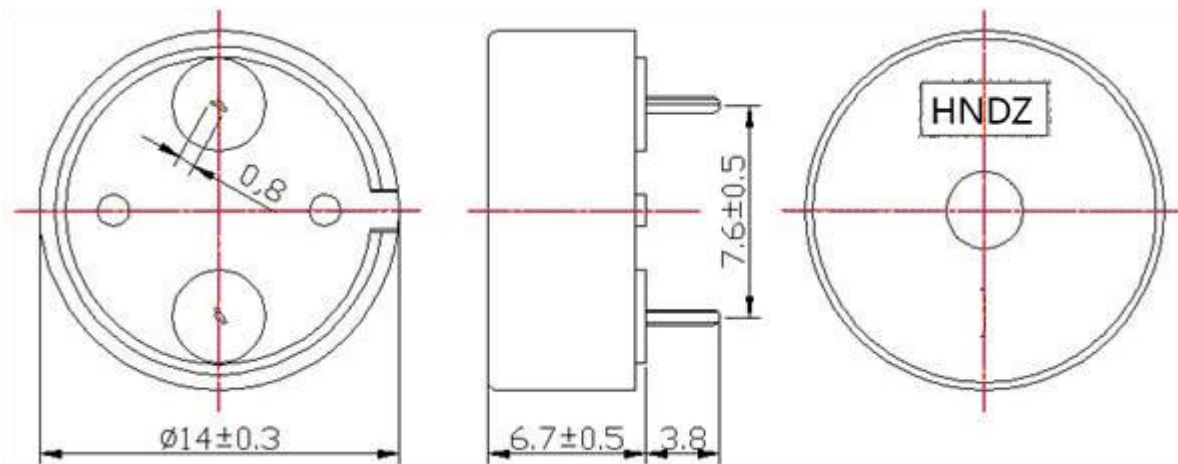



型号 Model No.: HNR-1407 PA7.5

测试方法 TEST METHOD

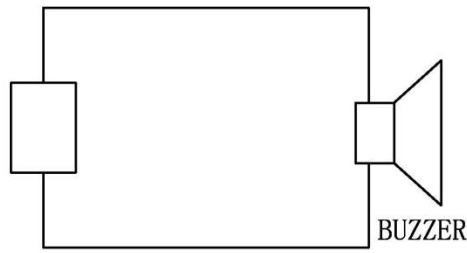

Acoustic Component Computer Test System

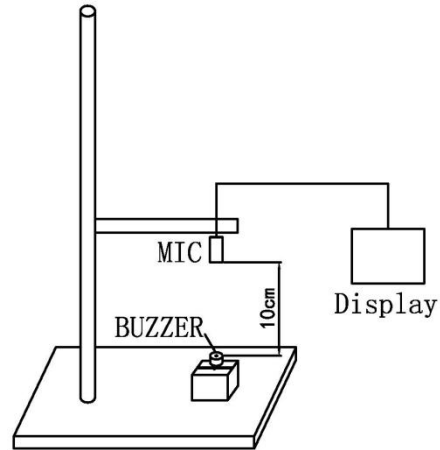

Acoustic Component Computer Test System

频响特性曲线

FREQUENCY RESPONSE

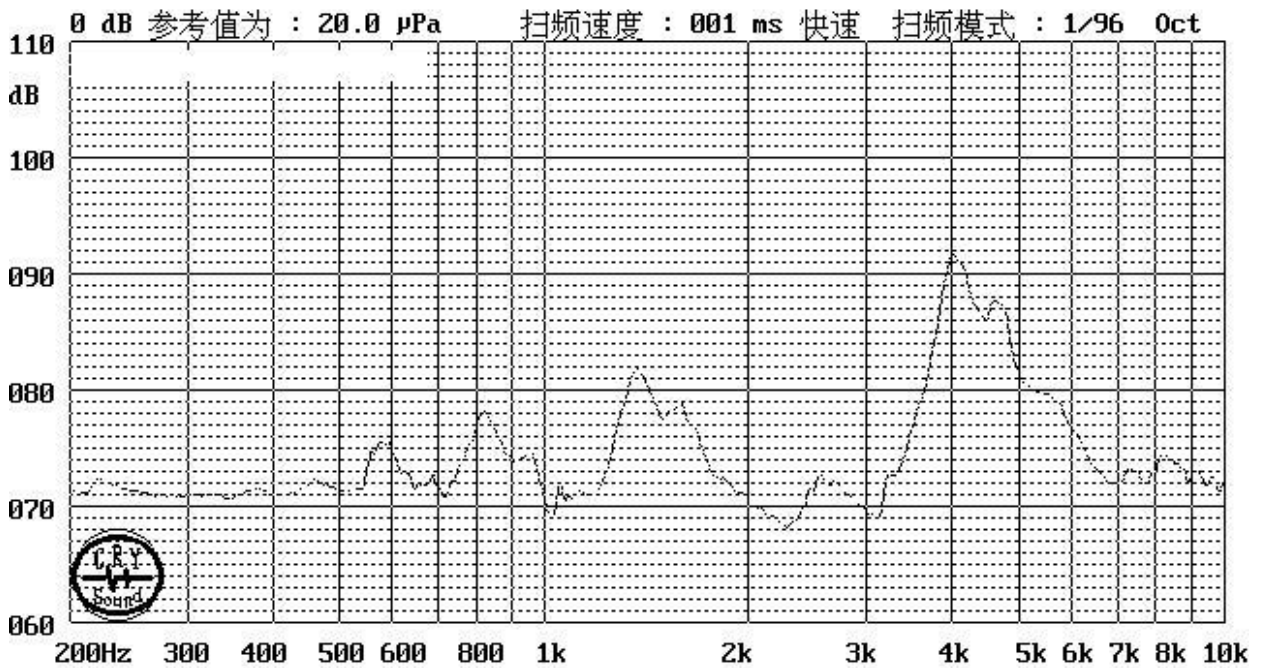
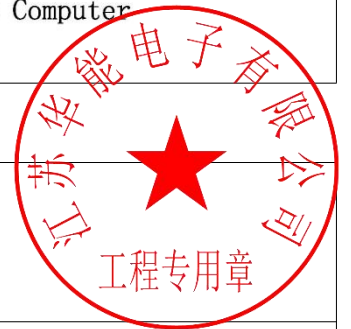



型号 Model No.: HNR-1407 PA7.5

可靠性测试 RELIABLE TEST

NO.	项目 ITEM	测试条件 TESTING CONDITION	试验后要求 VARIATION AFTER TEST
1	湿热 Humidity	将蜂鸣器置于温度在 $50 \pm 5^\circ\text{C}$ ，相对湿度在 90~95% 中，保持 48 小时后，在常温下恢复 2 小时再测试。 Place the buzzer in a temperature of $50 \pm 5^\circ\text{C}$ and a relative humidity of 90~95% for 48 hours, Restore at room temperature for 2 hours before testing.	测试后性能指标应满足承认书要求 All specifications must be satisfied after the test.
2	高温测试 High temp.	将蜂鸣器放置在 $+80 \pm 2^\circ\text{C}$ 中，保持 48 小时后，在常温下恢复 2 小时再测试。 Place the buzzer in $+80 \pm 2^\circ\text{C}$, keep it for 48 hours, Restore at room temperature for 2 hours before testing.	
3	低温测试 Low temp.	将蜂鸣器放置在 $-30 \pm 2^\circ\text{C}$ 中，保持 48 小时后，在常温下恢复 2 小时再测试。 Place the buzzer in $-30 \pm 2^\circ\text{C}$, keep it for 48 hours, Restore at room temperature for 2 hours before testing.	
4	温度循环测试 Temperature Cycling	将蜂鸣器在 -30°C 暴露 30min，在 $+80^\circ\text{C}$ 暴露 30min，五次循环后，在常温下恢复 2 小时再测试。 - $30 \pm 2^\circ\text{C}$, 30minutes room temp. 30 minutes $+80 \pm 2^\circ\text{C}$, 30 minutes room temp. 30 minutes 5 cycles	
5	跌落 Drop test	将蜂鸣器放置在水平位置，从 75cm 高度自由跌落到 10mm 硬木板上，跌落 3 次后，检查外观并测量电性能。 Place the buzzer in a horizontal position and drop it freely from a height of 75 cm to a 10 mm hardwood board. After three drops, check the appearance and measure the electrical performance	
6	振动 Vibration test	将蜂鸣器置于 10~55Hz、振幅在 1.0mm、XYZ 轴线方向上振动 0.5 小时 Make the test for the directions of XY and Z (total 0.5 hours). To-and-fro. sweep time (from 10 to 55 Hz and then from 55 to 10Hz) under single amplitude of 1.0mm is 1 minute.	
7	焊锡耐热性 Solder heat resistance	将产品针脚放置在 $250 \pm 5^\circ\text{C}$ 的锡炉里，持续 10 ± 0.5 秒，本体距熔融焊料 2.0mm。 The part leads (pins) shall be immersed in molten solder maintained at $250 \pm 5^\circ\text{C}$ for a period of 10 ± 0.5 seconds, The distance between the body and the molten solder is 2.0mm	





型号 Model No.: HNR-1407 PA7.5

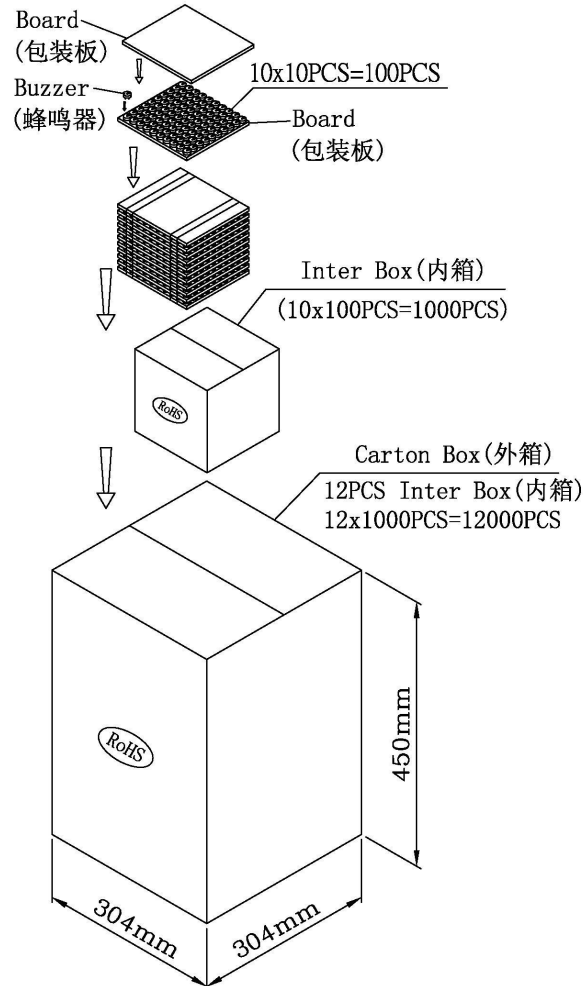

Board	135x135x6mm	1x100PCS=100PCS
Inter Box	142x142x140mm	10x100PCS=1000PCS
Carton Box	304x304x450mm	12x1000PCS=12000PCS

产品使用注意事项:

1. 请勿对蜂鸣器施加超出使用范围以外的电压。
2. 本产品为开放式设计，不符合防水/防胶渗漏要求。
3. 在有腐蚀性气体的地方长时间使用会将蜂鸣器部品腐蚀而不能正常工作。
4. 蜂鸣器的声压性能会随电压或电流大小负荷而改变，应满足电压或电流要求。
5. 避免出音孔前方有障板或被遮蔽会导致工作不稳定。
6. 蜂鸣器应在良好包装下储存，以避免受潮、生锈、针脚端氧化。

Precautions :

1. Do not apply voltage beyond the range of use of the buzzer.
2. This product is of open design and does not meet the requirements of waterproof/glue leakage.
3. Prolonged use in a place with corrosive gas will corrode the buzzer components and prevent them from working properly.
4. The sound pressure performance of the buzzer will change with the voltage or current load, and it should meet the voltage or current requirements.
5. Avoid that there is a baffle in front of the sound hole or it is covered, which will lead to unstable operation.
6. The buzzer should be stored in a good package to avoid moisture, rust and oxidation of the pin end.



