



MURS320 THRU MURS360

3.0 AMP Surface Mount Glass Ultra Fast Rectifier

Features

- Glass Passivated Die Construction
- Low forward voltage drop
- High current capability
- High reliability
- Metal silicon junction, majority carrier conduction
- Plastic Case Material has UL Flammability Classification Rating 94V-0

Mechanical Data

- Case: Molded plastic SMC
- Terminals: Plated leads solderable per MIL-STD-750, Method 2026 guaranteed
- Polarity: as marked on case
- Mounting Position: Any
- Making: Type Number

Case: SMC(DO-214AB)

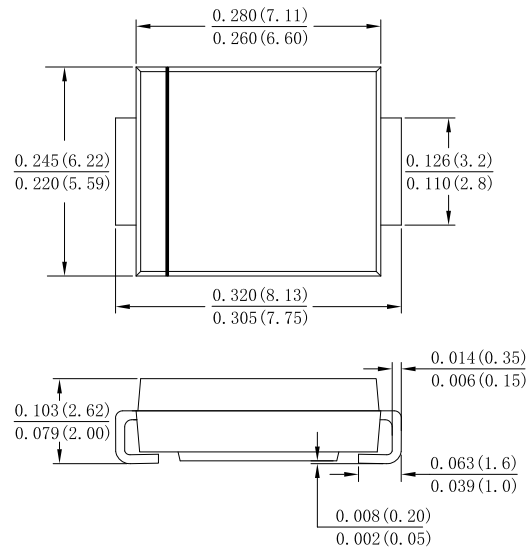

Dimensions in inches and (millimeters)

Maximum Ratings and Electrical Characteristics

Rating at 25°C ambient temperature unless otherwise specified

Single phase, half wave, 60Hz, resistive or inductive load

For capacitive load derate current by 20%

Type Number	Symbols	MURS320	MURS340	MURS360	Units
Maximum Recurrent Peak Reverse Voltage	V_{RRM}	200	400	600	V
Maximum RMS Voltage	V_{RMS}	140	280	420	V
Maximum DC Blocking Voltage	V_{DC}	200	400	600	V
Average Rectified Output Current @ $T_L=100^\circ\text{C}$	$I_{F(AV)}$	3.0			A
Peak Forward Surge Current 8.3ms Single half sine-wave superimposed on rated load (JEDEC Method)	I_{FSM}	110			A
I^2t Rating for Fusing ($t < 8.3\text{ms}$)	I^2t	50.215			A^2S
Forward Voltage @ $I_F=3.0\text{A}$	V_F	0.95	1.30		V
Peak Reverse Current @ $T_A=25^\circ\text{C}$	I_R	5.0			uA
At Rated DC Blocking Voltage @ $T_A=100^\circ\text{C}$		50			
Maximum reverse recovery time (Note 1)	T_{RR}	35	50		ns
Typical Junction Capacitance (Note 2)	C_J	25			pF
Typical Thermal Resistance Junction to Ambient	$R_{\theta JA}$	85			$^\circ\text{C}/\text{W}$
Operating and Storage Temperature Range	T_J, T_{STG}	-55 to +150			$^\circ\text{C}$

Note:

1. Reverse Recovery Test Conditions: $I_F=0.5\text{A}$, $I_R=1.0\text{A}$, $I_{RR}=0.25\text{A}$.
2. Measured at 1.0 MHz and Applied reverse Voltage of 4.0V D.C



MURS320 THRU MURS360

3.0 AMP Surface Mount Glass Ultra Fast Rectifier

Fig. 1 Forward Current Derating Curve

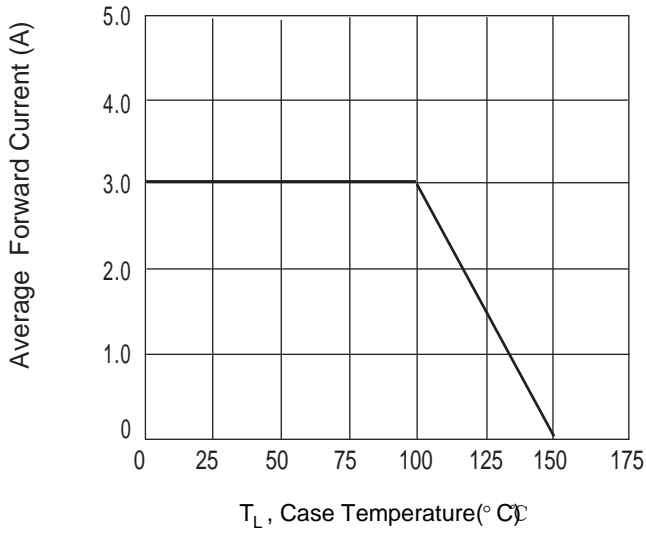

Fig. 2 Typ. Forward Characteristics

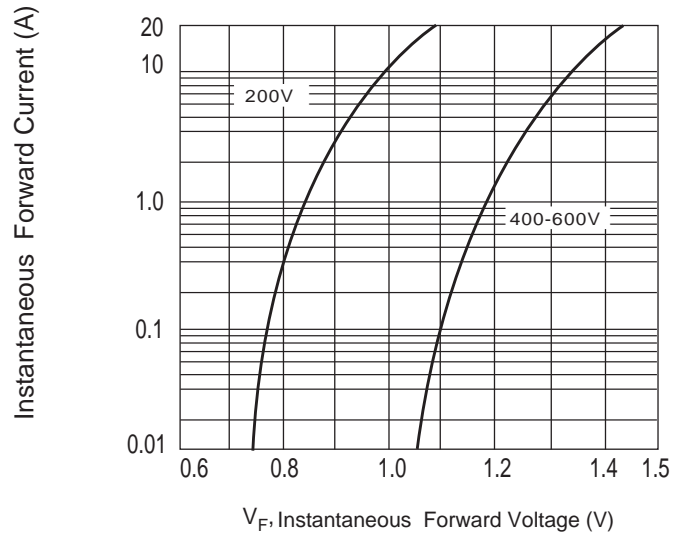

Fig. 3 Max Non-Repetitive Peak Fwd Surge Current

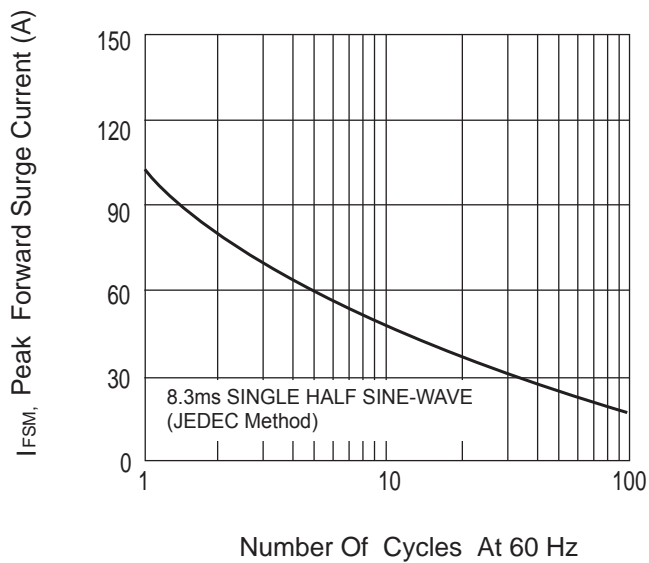

Fig.4 Typical Reverse Characteristics

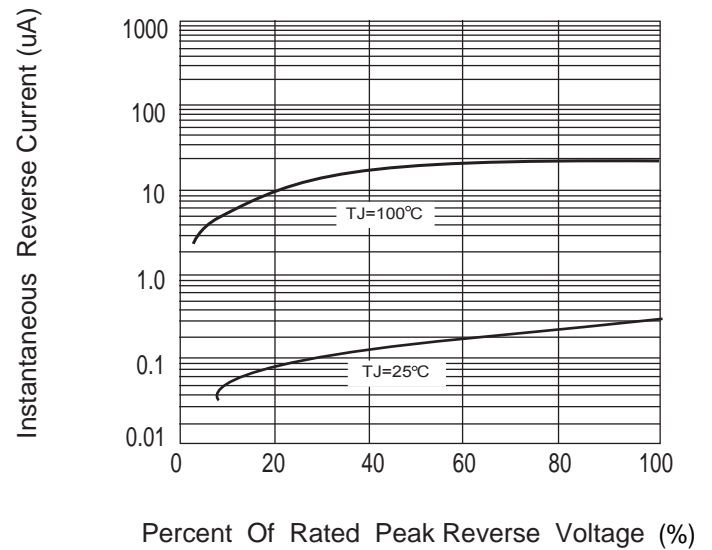
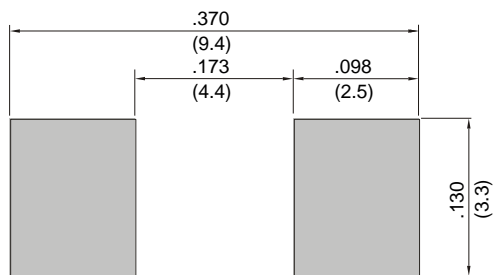

Fig.5 Mounting PAD Layout





Important Notice and Disclaimer

- Reproducing and modifying information of the document is prohibited without permission from XINNUO
- XINNUO reserves the right to make changes to this document and its products and specifications
- XINNUO disclaims any and all liability arising out of the application or use of any product including damages incidentally and consequentially occurred.
- XINNUO does not assume any and all implied warranties, including warranties of fitness for particular purpose, non-infringement and merchantability.
- Applications shown on the here in document are examples of standard use and operation. Customers are responsible in comprehending the suitable use in particular applications.
XINNUO makes no representation or warranty that such applications will be suitable for the specified use without further testing or modification.
- The products shown here in are not designed and authorized for equipments requiring high level of reliability or relating to human life and for any applications concerning life-saving or life-sustaining, such as medical instruments, transportation equipment, aerospace machinery et cetera. Customers using or selling these products for use in such applications do so at their own risk and agree to fully indemnify XINNUO for any damages resulting from such improper use or sale.
- Since XINNUO uses lot number as the tracking base, please provide the lot number for tracking when complaining.