

- NOTES:
- MATERIAL  
1-1: SUS-304 THICKNE=0.10MM
  - SPECIFICATIONS  
2-1: RATED CURRENT: 1.0A  
2-2: VOLTAGE RATING: 1.5V  
2-3: CONTACT RESISTANCE: 80mΩ/MAX  
2-4: WELDING THRUST: ≥3KG  
2-5: OPERATING TEMPERATURE: -40°C~+85°C
  - DURABILITY: 1500 CYCLES
  - SALT SPRAY TIME: 24H
  - ELECTROPLATE: THE NICKEL-PLATED SUBSTRATE IS 50u" MIN
  - REQUIREMENTS  
6-1: TERMINAL TO EAT FULL TIN, NOT PEELING, WELDING OBVIOUS COLOR AND OTHER ADVERSE  
6-2: ROHS, REACH, HF HALOGER ADVERSE OF DOMESTIC AND INTERNATIONAL ENVIRONMENTAL REQUIREMENTS

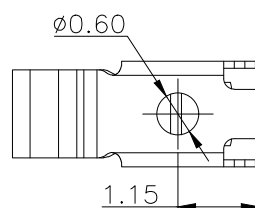

3.30(Max.Working Position)  
3.80(Working Position)  
3.90(Min.Working Position)

0.08 X

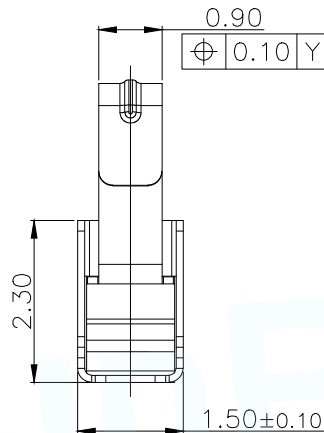
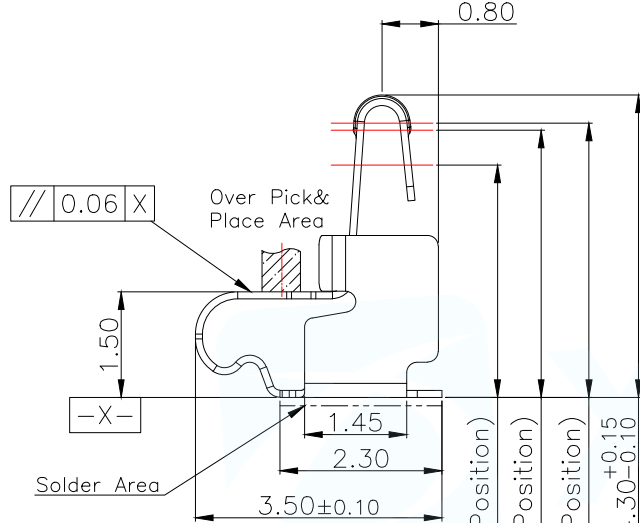
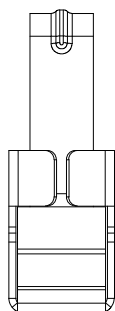
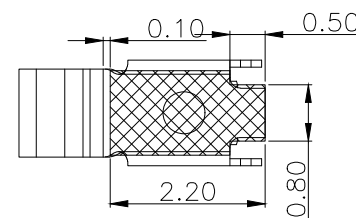

RECOMMENDED PCB LAYOUT  
TOLERANCE:±0.05MM  
(FOR REFERENCE ONLY)

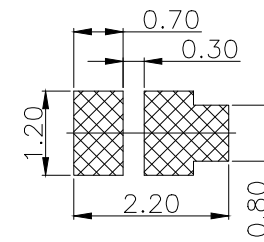

METAL MASK T=0.08  
TOLERANCE:±0.05MM  
(FOR REFERENCE ONLY)

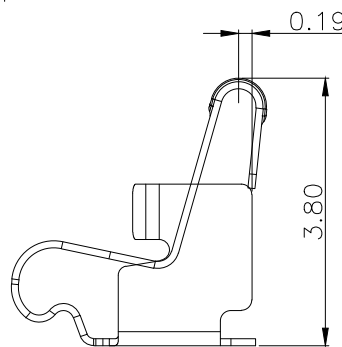
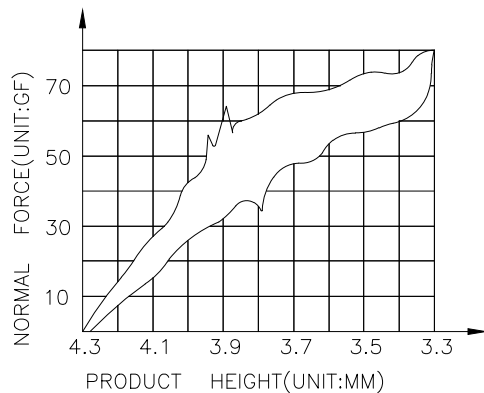

(For Reference Only)  
Stated At Compression

MANUFACTURE DWG		东莞市讯普电子科技有限公司 DongGuan XunPu Electronics Co.,Ltd	
UNLESS OTHERWISE SPECIFIED TOLERANCES			TITLE: 天线弹片 L3.50*W1.50*H4.30
DECIMALS:	ANGLES:		PAR: ASP-D4301-B01
X. ±0.30	X. ° ±0.20	DWN:	CHKD:
.X ±0.20	.X ° ±0.10	APVD:	SCALE N:A
.XX ±0.15	.XX ° ±0.5	CUSTOMER COPY	UNIT:MM
		SIZE:A4	UNIT:MM
		SHEET:1F1	REV:A

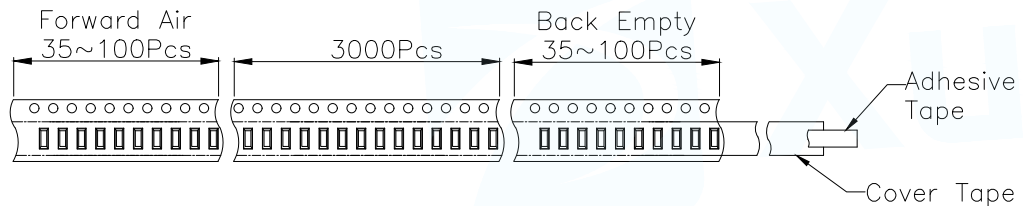
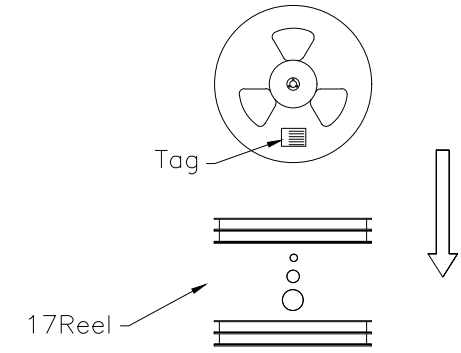
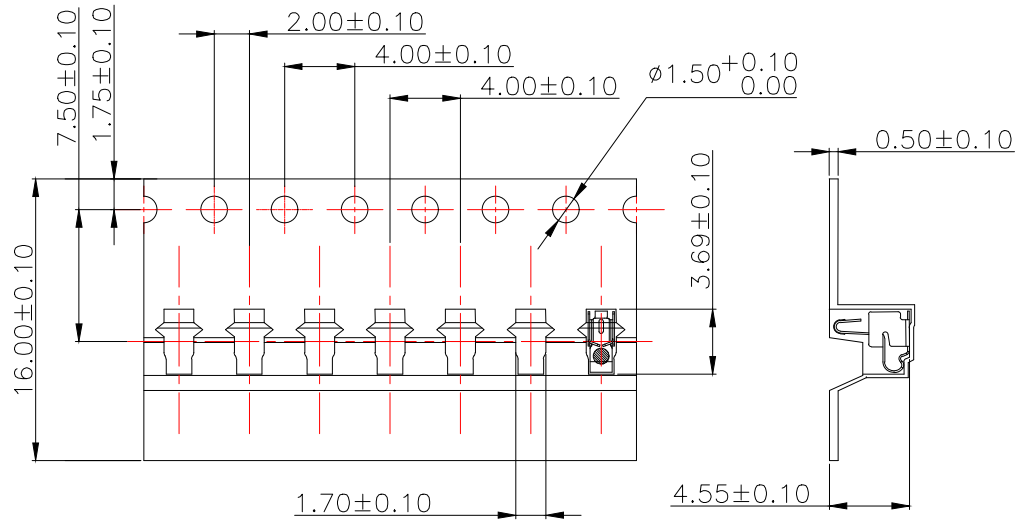

Carton Size  
290\*330\*4 K3K

Carton Size  
345\*345\*360 K=K

Customer To Use Direction

Pull Out Direction (出料方向)

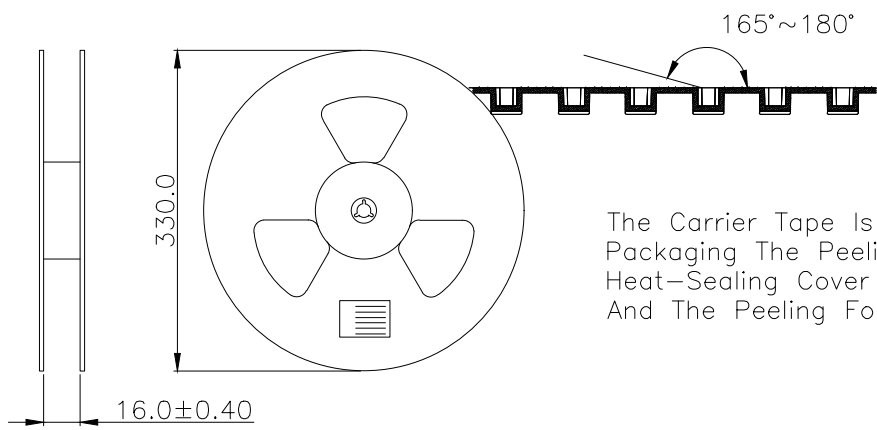

The Carrier Tape Is Heat-Sealed Packaging The Peeling Angle Of The Heat-Sealing Cover Tape Is 165°~180° And The Peeling Force Is 30~120g.

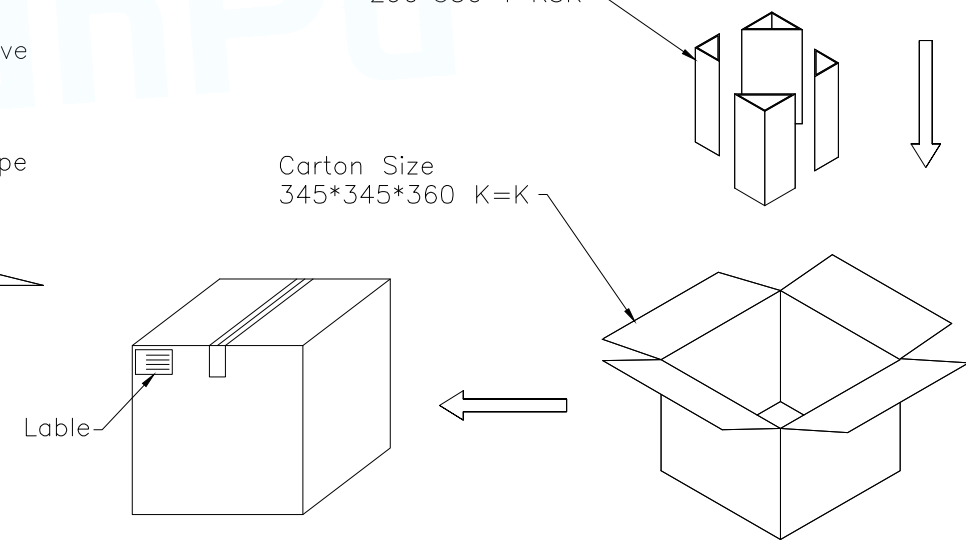

MANUFACTURE DWG		东莞市讯普电子科技有限公司 DongGuan XunPu Electronics Co.,Ltd	
UNLESS OTHERWISE SPECIFIED TOLERANCES		TITLE: 天线弹片 L3.50*W1.50*H4.30	
		PAR	ASP-D4301-B01
DECIMALS:	ANGLES:	DWN	
X. ±0.30	X. ° ±0.20	CHKD	
.X ±0.20	.X ° ±0.10	APVD	
.XX ±0.15	.XX ° ±0.5	SCALE N:A	UNIT:MM
		SIZE:A4	SHEET:1F1
		CUSTOMER COPY	REV:A