

3D View

NOTES:

- 1:MATERIAL
 - 1-1: SUS-304 THICKNE=0.10MM
- 2:SPECIFICATIONS
 - 2-1: RATED CURRENT: 1.0A
 - 2-2: VOLTAGE RATING: 1.5V
 - 2-3: CONTACT RESISTANCE: 80mΩ/MAX
 - 2-4: WELDING THRUST: ≥3KG
 - 2-5: OPERATING TEMPERATURE: -40°C~+85°C
- 3:DURABILITY: 1500 CYCLES
- 4:SALT SPRAY TIME: 24H
- 5:ELECTROPLATE: THE NICKEL-PLATED SUBSTRATE IS 50u"MIN
- 6:REQUIREMENTS
 - 6-1:TERMINAL TO EAT FULL TIN,NOTPEELING, WELDING OBVIOUS COLOR AND OTHED ADVERSE
 - 6-2:ROHS, REACH, HF HALOGER ADVERSE OF DOMESTIC AND INTERNATIONAL ENVIRONMNTAL REQUIREMENTS

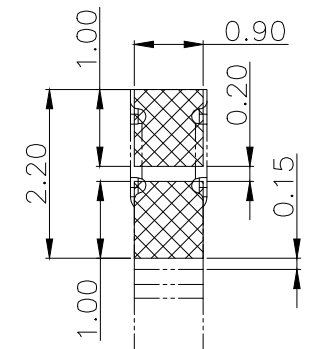
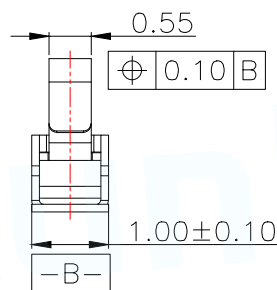
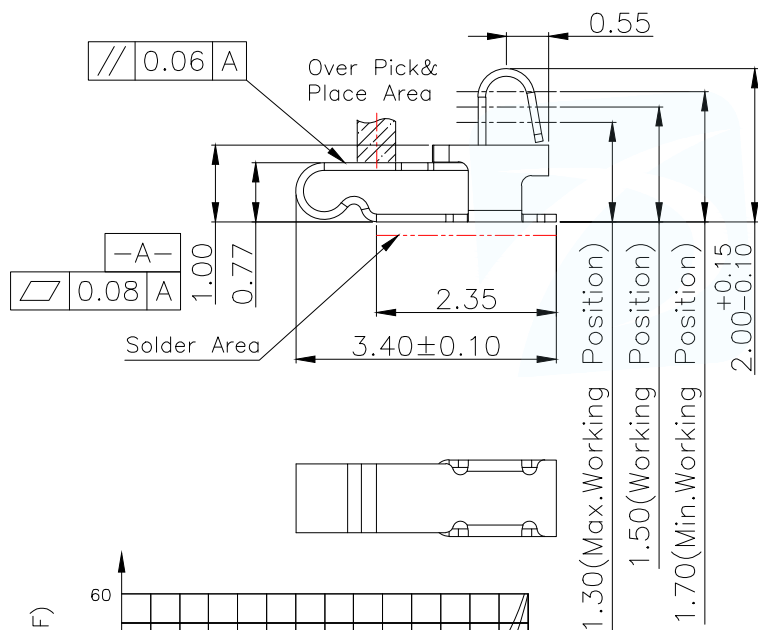

METAL MASK T=0.08

TOLERANCE:±0.05MM
(FOR REFERENCE ONLY)

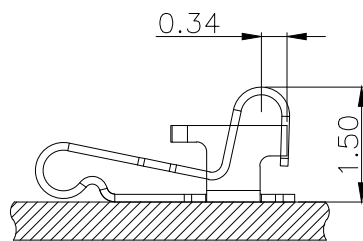
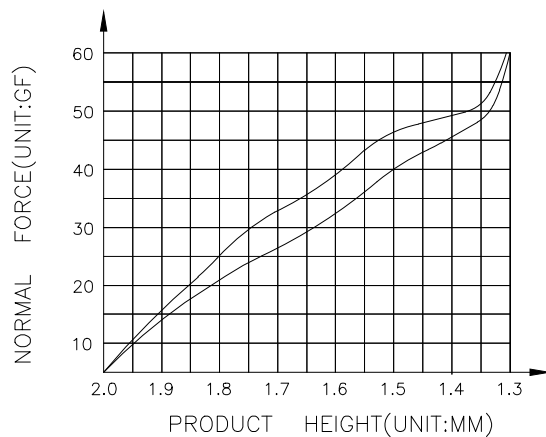

(For Reference Only)
Stated At Compression

MANUFACTURE DWG		东莞市讯普电子科技有限公司 DongGuan XunPu Electronics Co.,Ltd	
UNLESS OTHERWISE SPECIFIED TOLERANCES			TITLE: 天线弹片 L3.40*W1.00*H2.00
DECIMALS:	ANGLES:		PAR ASP-D2003-B01
X. ±0.30	X. ° ±0.20	DWN	CHKD
.X ±0.20	.X ° ±0.10	APVD	
.XX ±0.15	.XX ° ±0.5	SCALE N:A	UNIT:MM
		SIZE:A4	SHEET:1F1
		CUSTOMER COPY	REV:A

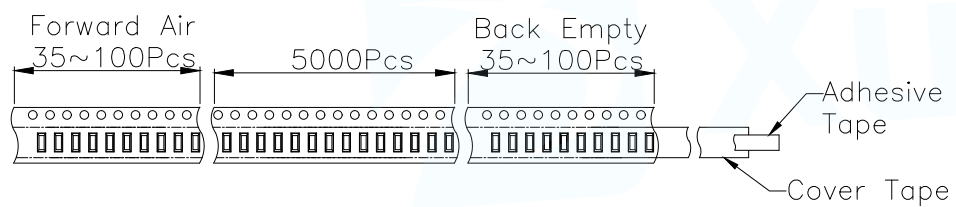
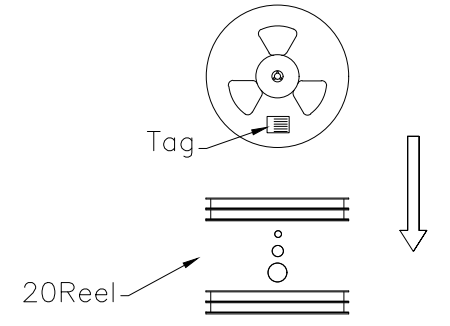
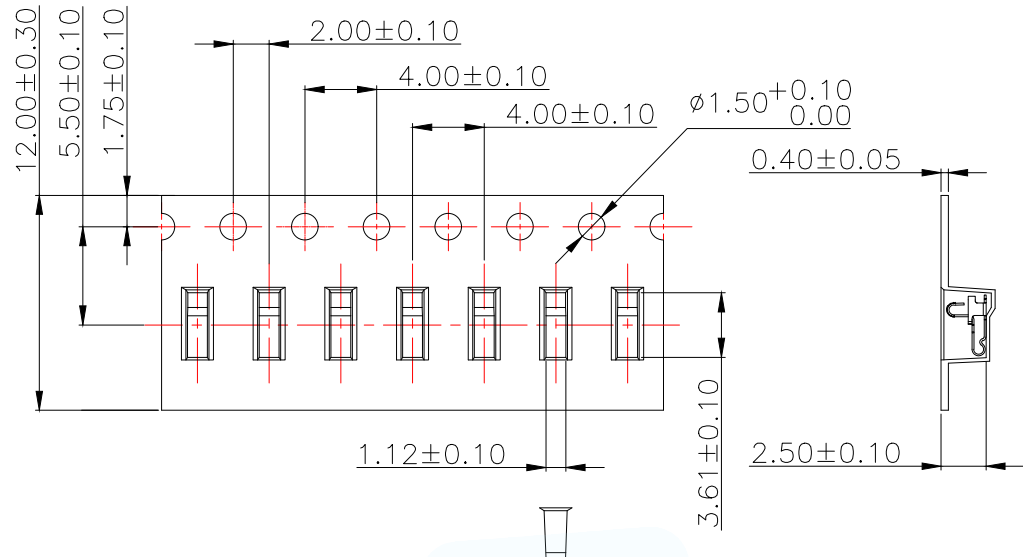

Customer To Use Direction Pull Out Direction (出料方向)

Carton Size 290*330*4 K3K

Carton Size 345*345*360 K=K

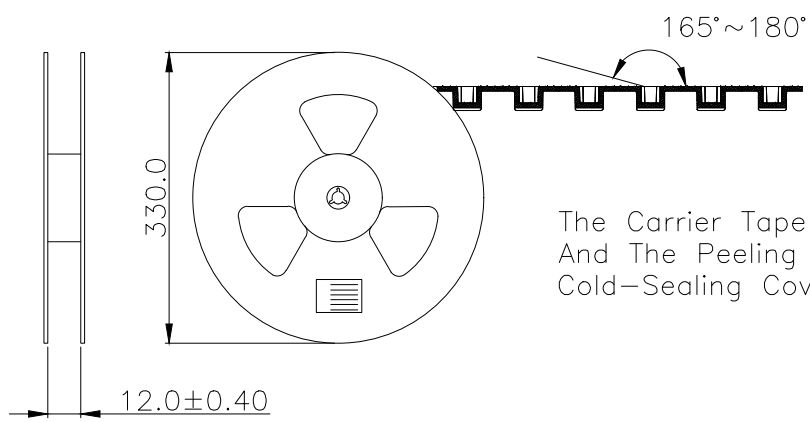
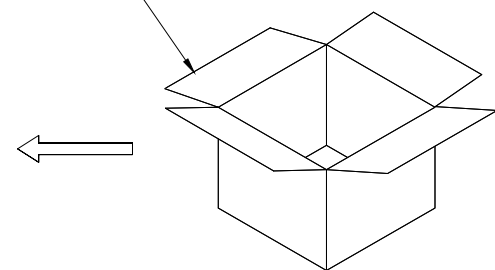
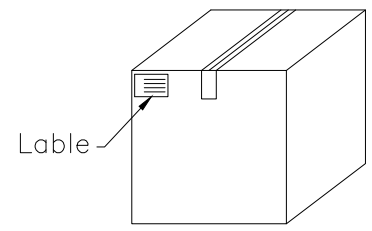

The Carrier Tape Is Cold-Sealed And The Peeling Angle Of The Cold-Sealing Cover Tape Is 165°~180°.

MANUFACTURE DWG		东莞市讯普电子科技有限公司 DongGuan XunPu Electronics Co.,Ltd	
UNLESS OTHERWISE SPECIFIED TOLERANCES		TITLE: 天线弹片 L3.40*W1.00*H2.00	
		PAR	ASP-D2003-B01
DECIMALS:		DWN	
ANGLES:		CHKD	
X. ±0.30	X. ° ±0.20	APVD	
.X ±0.20	.X ° ±0.10	SCALE N:A	UNIT:MM
.XX ±0.15	.XX ° ±0.5	SIZE:A4	UNIT:MM
CUSTOMER COPY		SHEET:1F1	REV:A