

12	13	14	15
MAPX	MODIFICATION	DATE	DRAW APPROVE

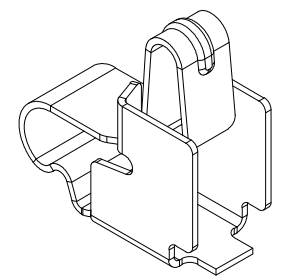

3D View

- NOTES:
- 1:MATERIAL  
1-1: SUS-304 THICKNE=0.10MM
  - 2:SPECIFICATIONS  
2-1: RATED CURRENT: 1.0A  
2-2: VOLTAGE RATING: 1.5V  
2-3: CONTACT RESISTANCE: 80mΩ/MAX  
2-4: WELDING THRUST: ≥3KG  
2-5: OPERATING TEMPERATURE: -40°C~+85°C
  - 3:DURABILITY: 1500 CYCLES
  - 4:SALT SPRAY TIME: 24H
  - 5:ELECTROPLATE: THE NICKEL-PLATED SUBSTRATE IS 50u" MIN
  - 6:REQUIREMENTS  
6-1:TERMINAL TO EAT FULL TIN,NOTPEELING, WELDING OBVIOUS COLOR AND OTHED ADVERSE  
6-2:ROHS、REACH、HF HALOGER ADVERSE OF DOMESTIC AND INTERNATIONAL ENVIRONMNTAL REQUIREMENTS

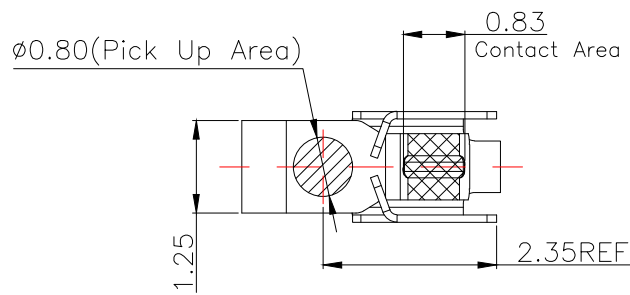
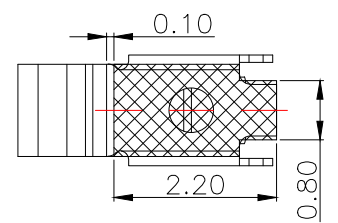
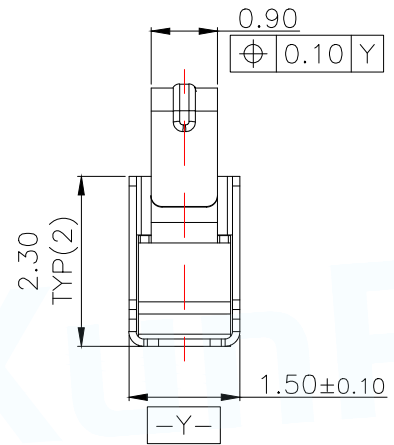
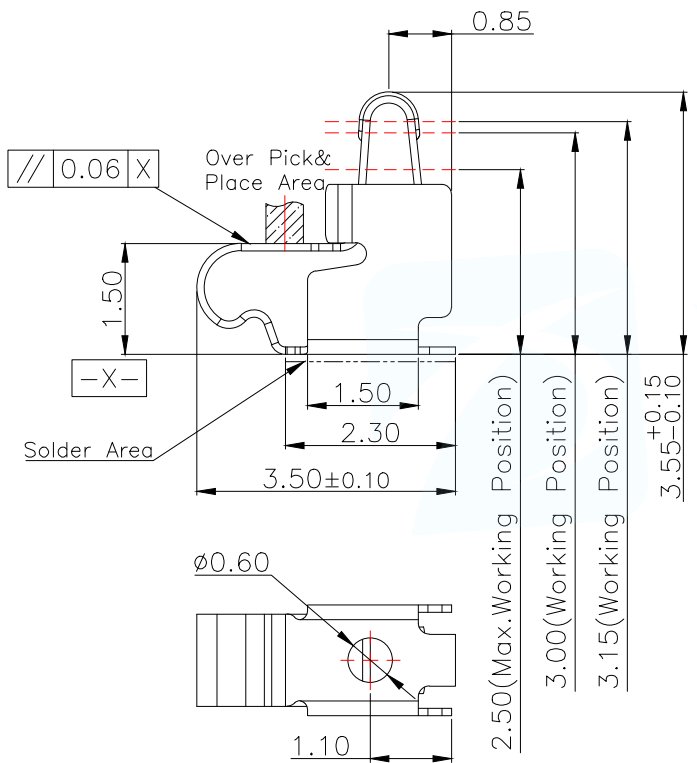

RECOMMENDED PCB LAYOUT

TOLERANCE:±0.05MM  
(FOR REFERENCE ONLY)

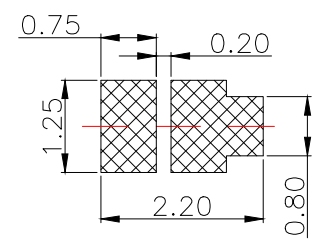

METAL MASK T=0.08

TOLERANCE:±0.05MM  
(FOR REFERENCE ONLY)

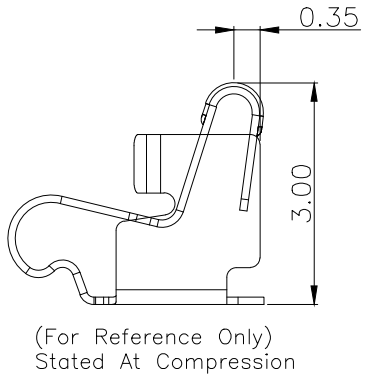
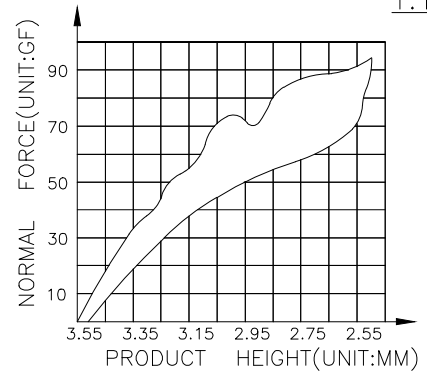

MANUFACTURE DWG		东莞市讯普电子科技有限公司 DongGuan XunPu Electronics Co.,Ltd	
UNLESS OTHERWISE SPECIFIED TOLERANCES			TITLE: 天线弹片 L3.50*W1.50*H3.55
DECIMALS:	ANGLES:		PAR ASP-D3501-B01
X. ±0.30	X. ° ±0.20	DWN	
.X ±0.20	.X ° ±0.10	CHKD	
.XX ±0.15	.XX ° ±0.5	APVD	
CUSTOMER COPY		SCALE N:A	UNIT:MM
		SIZE:A4	SHEET:1F1
			REV:A

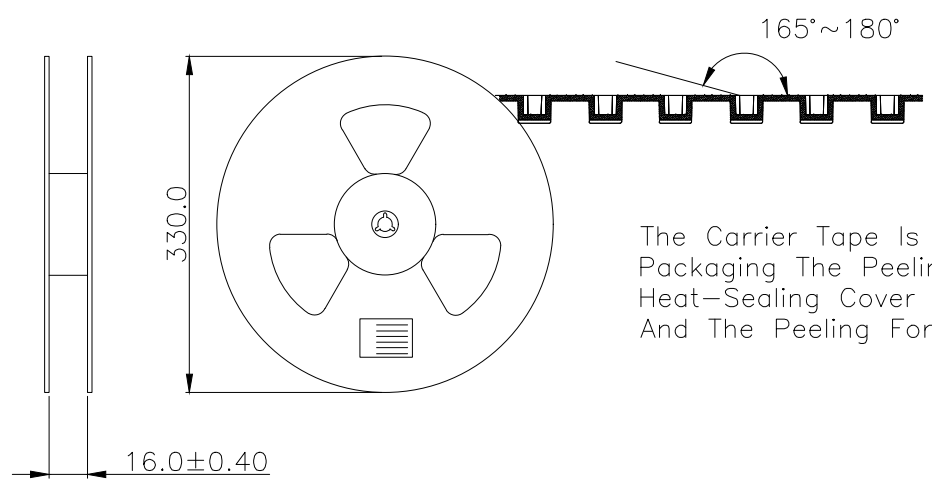
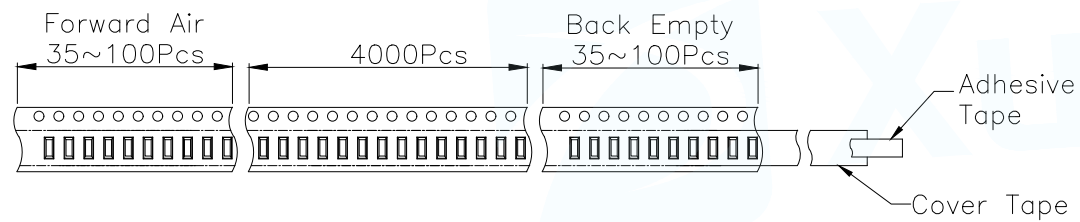
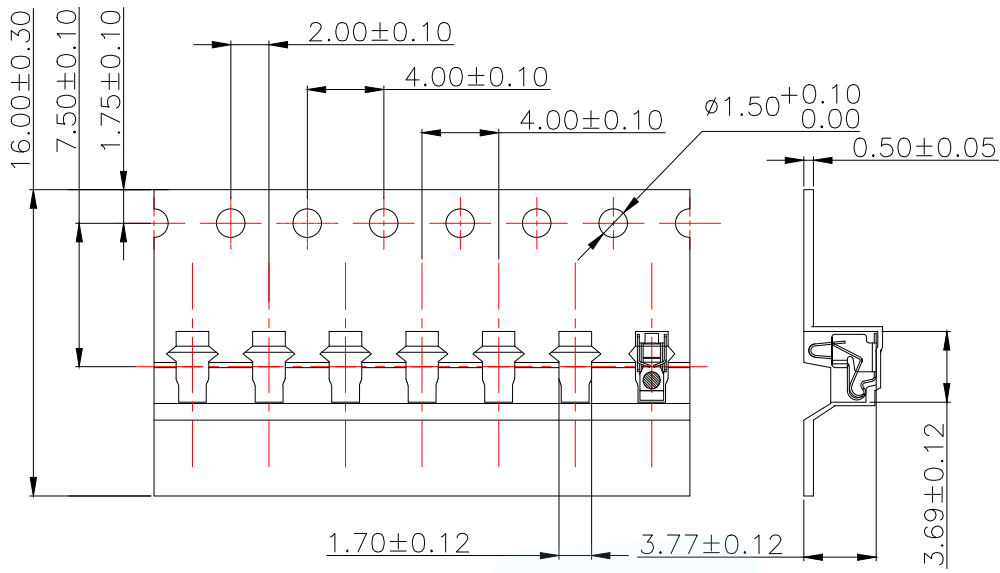

The Carrier Tape Is Heat-Sealed Packaging The Peeling Angle Of The Heat-Sealing Cover Tape Is 165°~180° And The Peeling Force Is 30~120g.

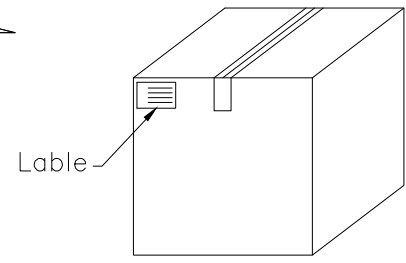
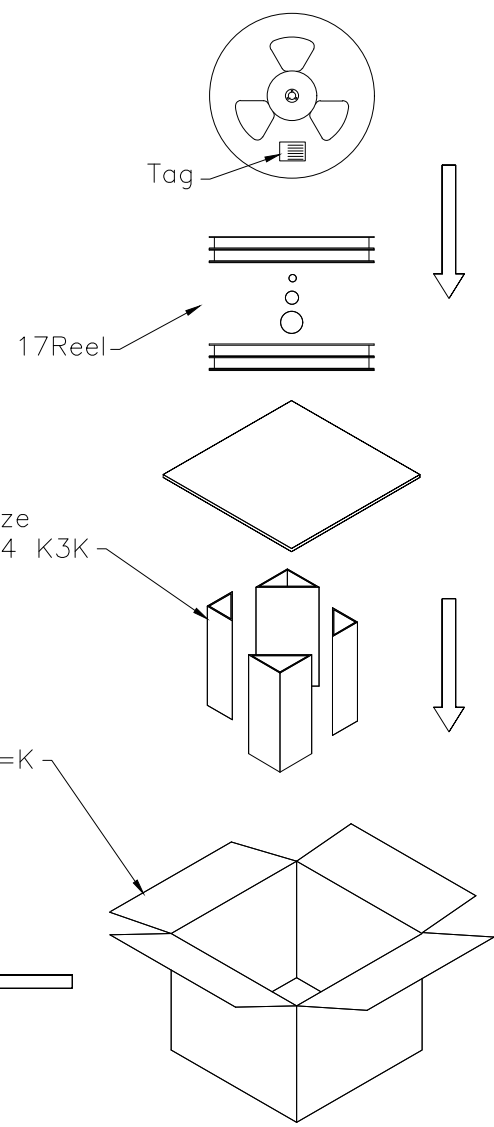

MANUFACTURE DWG		东莞市讯普电子科技有限公司 DongGuan XunPu Electronics Co.,Ltd	
UNLESS OTHERWISE SPECIFIED TOLERANCES			TITLE: 天线弹片 L3.50*W1.50*H3.55
			PAR ASP-D3501-B01
			DWN
DECIMALS:	ANGLES:	CHKD	
X. ±0.30	X. ° ±0.20	APVD	
.X ±0.20	.X ° ±0.10	SCALE N:A	UNIT:MM
.XX ±0.15	.XX ° ±0.5	SIZE:A4	UNIT:MM
		CUSTOMER COPY	SHEET:1F1
			REV:A