

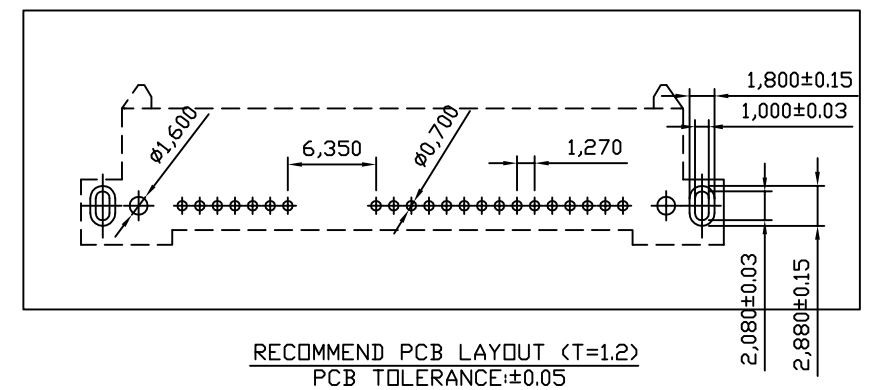

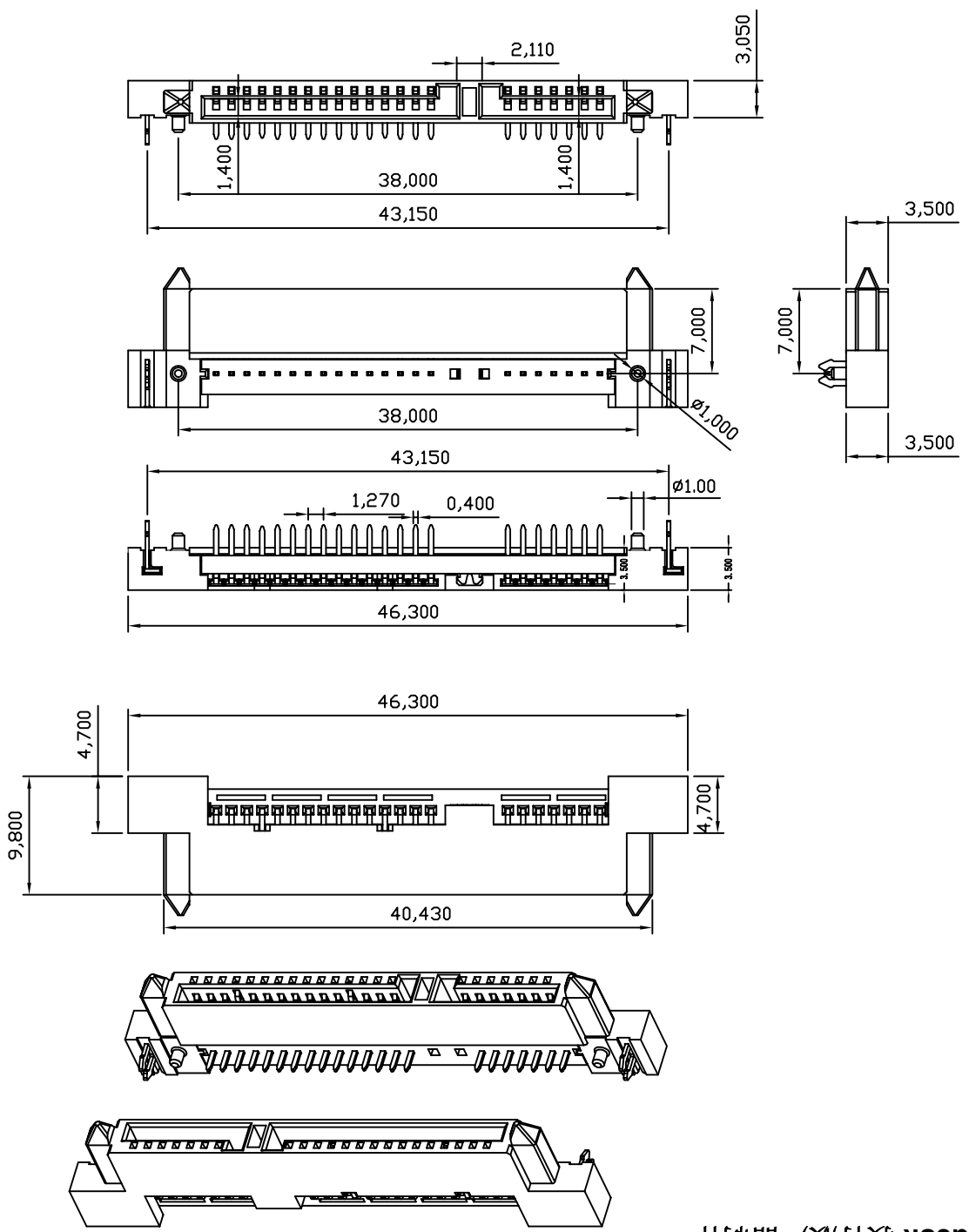

修订 REV NO	标记 MARK	修改摘要 REVISION DESCRIPTION	签名 SIGNATURE	日期 DATE
		NEW DRG		2016-03-12

NOTES:

- MATERIAL:  
HOUSING: LCP UL 94V-0  
COLOR: BLACK  
CONTACT: PHOSPHOR BRONZE  
BOARD LOCK: BRASS
- FINISH:  
CONTACT: GOLD PLATING ON CONTACT AREA  
100u" MIN.TIN PLATING ON SOLDER TAILS  
50u" MIN.NICKEL UNDERPLATING OVER ALL  
BOARD LOCK: 100u" MIN.TIN PLATING ALL  
50u" MIN.NICKEL UNDERPLATING OVER ALL



		深圳市华德共创科技有限公司 Shenzhen Huade co-create Technology Co.,LTD 电话: 0755-27111216 传真: 0755-29940187			
-TOLERANCES- UNLESS OTHERWISE SPECIFIED 公差参数表		 		TITLE: SATA 7+15P母座DIP板上型 产品名称: H=3.5	
X.X	±0.30	X.X°	±3°	APPD: 核准:	PART NO: 产品编号: HDGCYLSY-SATA-111
X.XX	±0.20	X.XX°	±2°	CHECK: 校对: 王建业	DATE SCALE UNIT CODE NUMBER
X.XXX	±0.10	X.XXX°	±1°	DRAW: 绘图: 黄艳兰	2016-03-12 1:1 mm A001

由 Autodesk 教育版产品制作

由 Autodesk 教育版产品制作