

修 订	标 记	修 改 描 要	签 名	日 期
REV NO		REV NO		DATE
		NEW DRG		2016-03-12

SPECIFICATI N:  
 1.MATERIAL:  
 HDUSING: L&P UL 94V-0  
 ♂ L R:BLACK  
 ♂ NTA&T: PH SPH R BR NZE ♂5191R-H,T=0.25mm  
 PEG: BRASS ♂2680R-H,T=0.30mm  
 2.FINISH:  
 C NTA&T:1u"3u"5u"15u" ♂DLD/TIN PLATING N ♂ NTA&T AREA  
 100u" MIN. TIN PLATING N ♂LDERTAILS  
 50u" MIN.NICKEL UNDERPLATING VER ALL  
 PEG:100u" MIN. TIN PLATING N S LDERTAILS  
 50u" MIN.NICKEL UNDERPLATING VER ALL

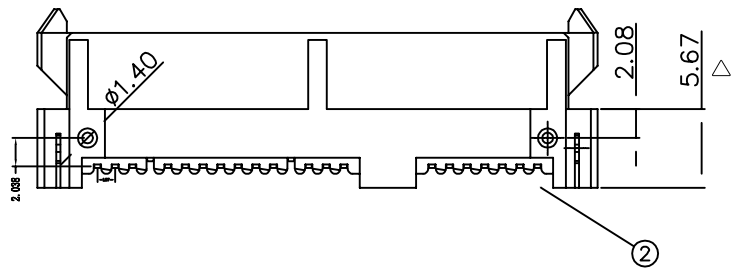

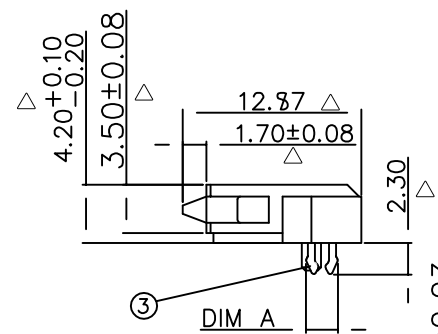
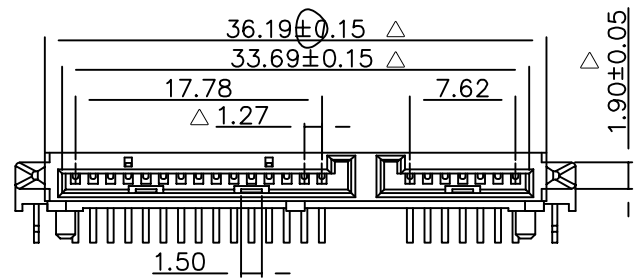
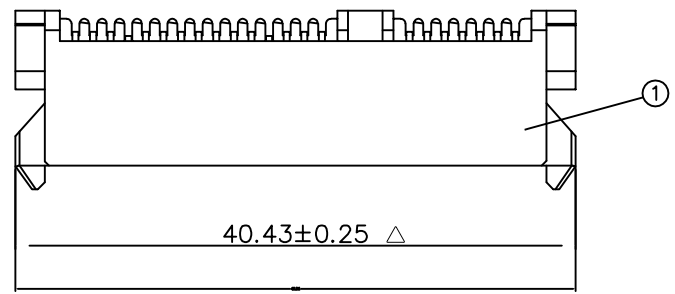
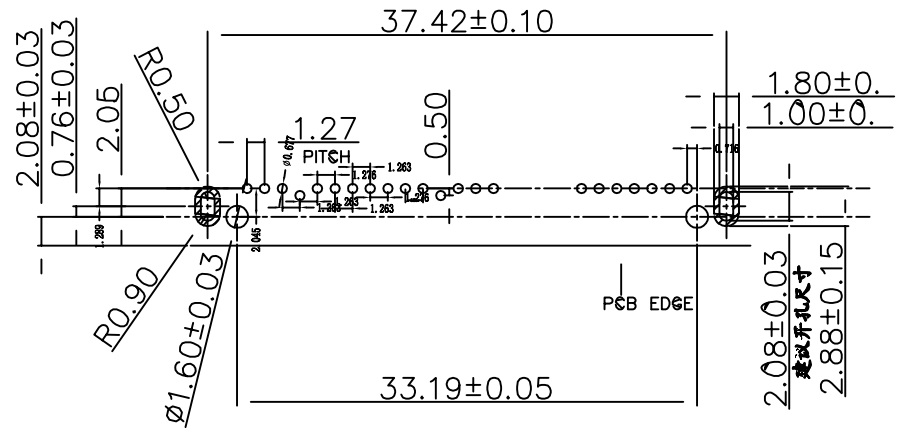

ITEM	DIM A	形状	DIM B
P1	2.10	⌋	2.08
P2	2.30	⌋	2.28
P3	2.45	⌋	

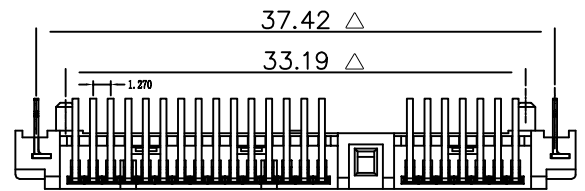

REC MMEND PCB LAYDUT (T=1.2)



		深圳市华德共创科技有限公司 Shenzhen Huade co-create Technology Co.,LTD 电话: 0755-27111216 传真: 0755-29940187			
-TOLERANCES- UNLESS OTHERWISE SPECIFIED 公差参数表		 		TITLE: SATA 7+15P母座DIP板上型 产品名称: H=4.2	
X.X	±0.30	X.X°	±3°	APPD: 核准:	PART NO: 产品编号: HDGCYLSY-SATA-105
X.XX	±0.20	X.XX°	±2°	CHECK: 校对: 王建业	DATE SCALE UNIT CODE NUMBER
X.XXX	±0.10	X.XXX°	±1°	DRAW: 绘图: 黄艳兰	2016-03-12 1:1 mm A001

由 Autodesk 教育版产品制作

由 Autodesk 教育版产品制作