

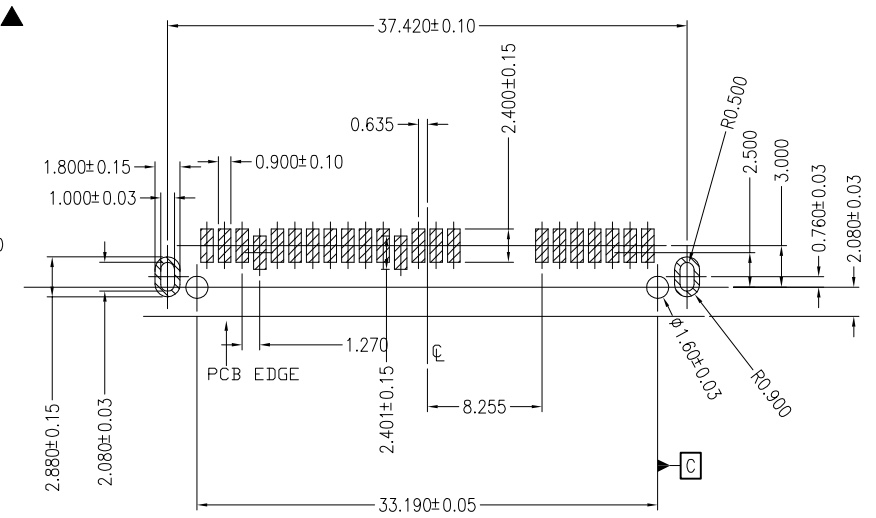

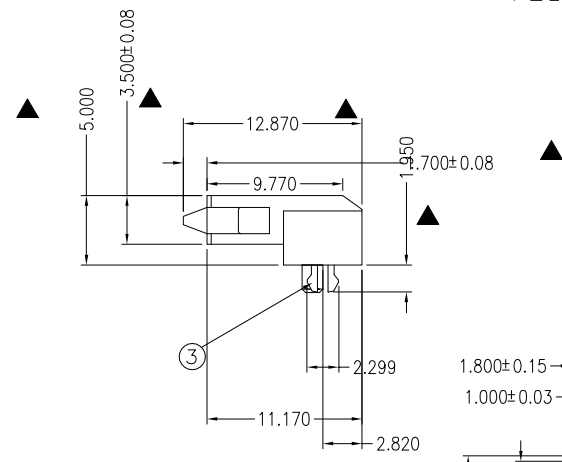

修订	标记	修改摘要	签名	日期
REV NO		NEW DRG		2016-03-12

SPECIFICATION:  
 1.MATERIAL:  
 HOUSING: LCP 30% G/F UL 94V-0  
 COLOR:BLACK  
 CONTACT: PHOSPHOR BRONZE C5191R-H,T=0.25mm  
 PEG: BRASS C2680R-H,T=0.45mm  
 2.FINISH:  
 CONTACT:5u" GOLD/TIN PLATING ON CONTACT AREA  
 100u" MIN. TIN PLATING ON SOLDERTAILS  
 50u" MIN.NICKEL UNDERPLATING OVER ALL  
 PEG:100u" MIN. TIN PLATING ON SOLDERTAILS  
 50u" MIN.NICKEL UNDERPLATING OVER ALL

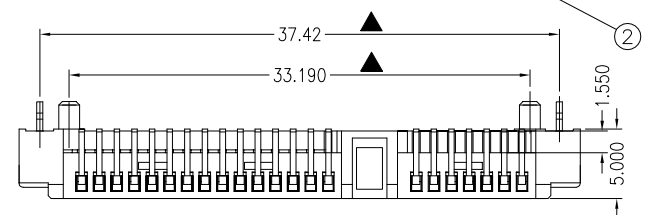
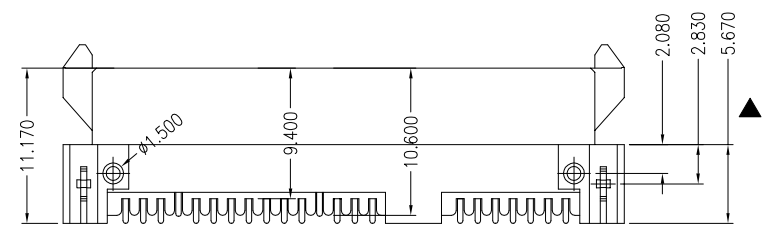
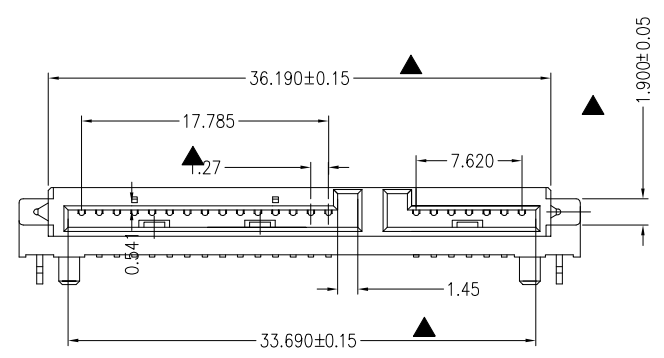
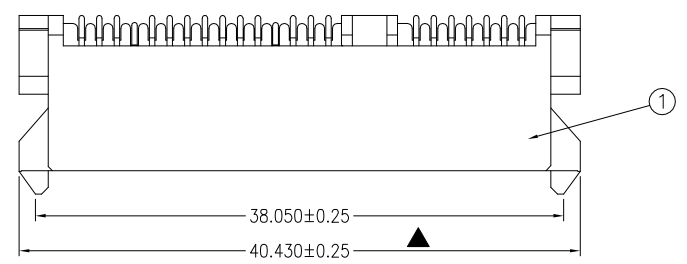

 深圳市华德共创科技有限公司 Shenzhen Huade co-create Technology Co.,LTD 电话: 0755-27111216 传真: 0755-29940187		TITLE: SATA 7+15P母座SMT板上型 产品名称: H=5.0						
-TOLERANCES- UNLESS OTHERWISE SPECIFIED 公差参数表		 		PART NO: HDGCYLSY-SATA-110 产品编号:				
X.X	±0.30	X.X°	±3°	APPD: 核准:	DATE	SCALE	UNIT	CODE NUMBER
X.XX	±0.20	X.XX°	±2°	CHECK: 校对: 王建业	2016-03-12	1:1	mm	A001
X.XXX	±0.10	X.XXX°	±1°	DRAW: 绘图: 黄艳兰				

由 Autodesk 教育版产品制作

由 Autodesk 教育版产品制作