

1. DESCRIPTION

The XL/XD74LS279 offers 4 basic \bar{S} - \bar{R} flip-flop latches in one 16-pin, the 300-mil package. Under conventional operation, the \bar{S} - \bar{R} inputs are normally held high. When the \bar{S} input is pulsed low, the Q output will be set high. When \bar{R} is pulsed low, the Q output will be reset low. Normally, the \bar{S} - \bar{R} inputs should not be taken low simultaneously. The Q output will be unpredictable in this condition.

2. PIN CONFIGURATIONS

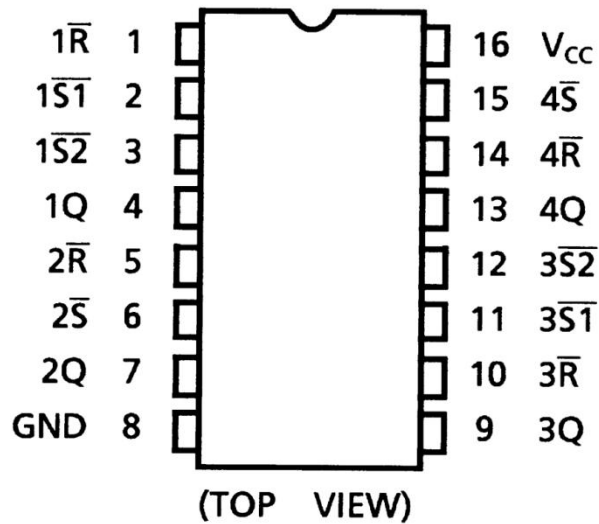

3. LOGIC DIAGRAM

(latches 1 and 3)

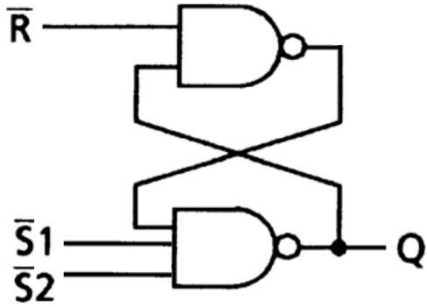

(latches 2 and 4)

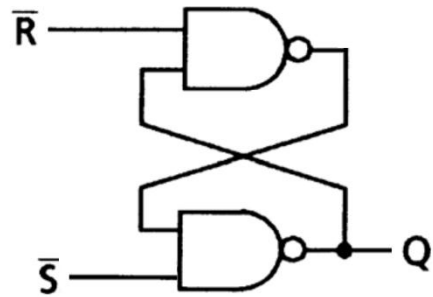

INPUTS		OUTPUT
\bar{S} ↑	\bar{R}	Q
H	H	Q_0
L	H	H
H	L	L
L	L	H

4. SCHEMATICS OF INPUTS AND OUTPUTS

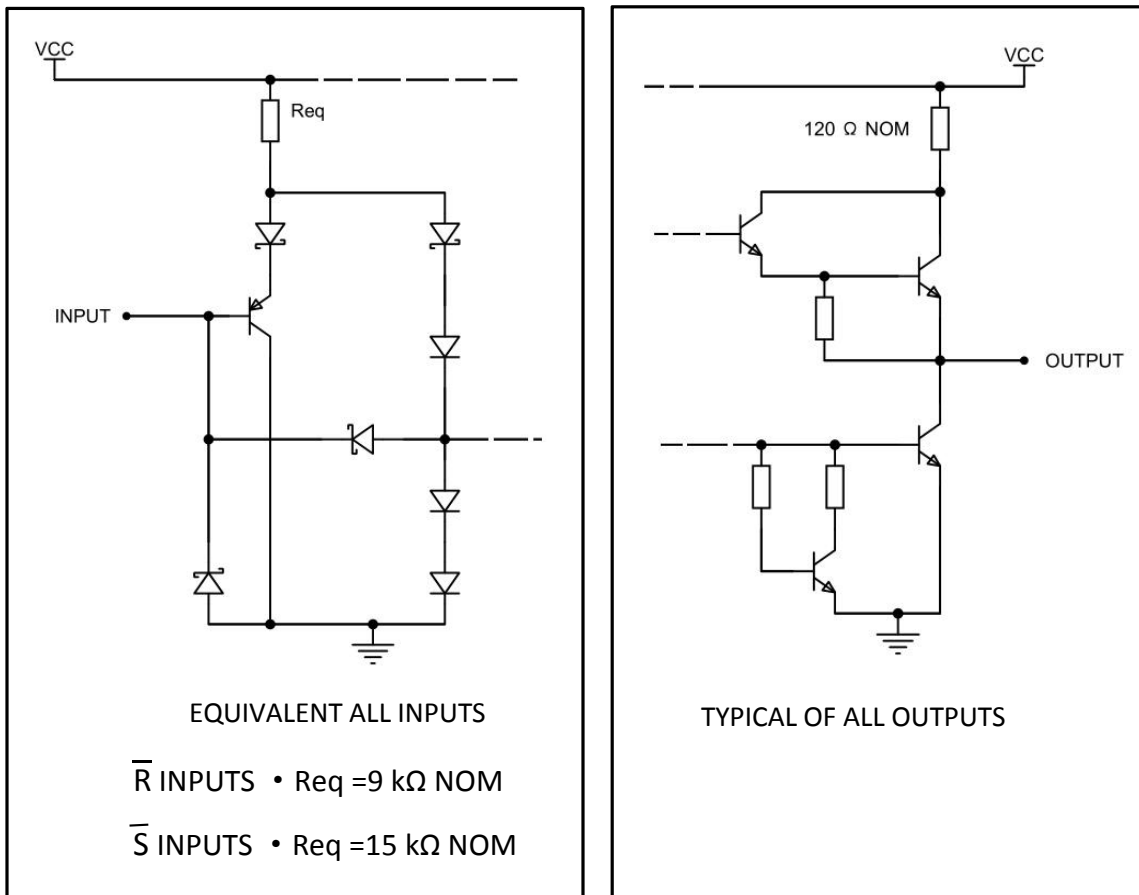

5. ABSOLUTE MAXIMUM RATINGS OVER OPERATING FREE-AIR TEMPERATURE RANGE (UNLESS OTHERWISE NOTES)

Supply voltage, V_{CC} (see Note 1).....	7V
Input voltage, V_I : 74LS279.....	7V
Operating free-air temperature range: SOP package.....	0°C to 70°C
DIP package.....	0°C to 70°C
Storage temperature range, T_{stg}	-65°C to 150°C

NOTE 1 : Voltgae values are with respect to network ground terminal.

6. RECOMMENDED OPERATING CONDITIONS

		XL/XD74LS279			UNIT
		MIN	NOM	MAX	
V _{CC}	Supply voltage	4.75	5	5.25	V
V _{IH}	High-level input voltage	2			V
V _{IL}	Low-level input voltage			0.8	V
I _{OH}	High-level output current			-0.4	mA
I _{OL}	Low-level output current	20		8	mA
T _A	Operating free-air temperature	0		70	°C

7. ELECTRICAL CHARACTERISTICS OVER RECOMMENDED OPERATING FREE-AIR RANGE (UNLESS OTHERWISE NOTED)

PARAMETER	TEST CONDITIONS [†]	XL/XD74LS279			UNIT
		MIN	TYP [‡]	MAX	
V _{IK}	V _{CC} = MIN, I _I = -18 mA			-1.5	V
V _{OH}	V _{CC} = MIN, V _{IL} = MAX, I _{OH} = -0.4 mA	2.7	3.4		V
V _{OL}	V _{CC} = MIN, V _{IH} = 2 V		0.25	0.4	V
			0.25	0.5	
I _I	V _{CC} = MAX, V _I = 7 V			0.1	mA
I _{IH}	V _{CC} = MAX, V _I = 2.7 V			20	μA
I _{IL}	V _{CC} = MAX, V _I = 0.4 V			-0.2	mA
I _{OS} [§]	V _{CC} = MAX	-20		-100	mA
I _{CC}	V _{CC} = MAX, See note2		3.8	7	mA

[†] For conditions shown as MIN or MAX, use the appropriate value specified under recommended operating conditions.

[‡] All typical values are at V_{CC} = 5 V, T_A = 25°C.

[§] Not more than one output should be shorted at a time, and the duration of the short-circuit should not exceed one second.

NOTE 2: I_{CC} is measured with all R inputs grounded, all S inputs at 4.5V, and all outputs open.

8. SWITCHING CHARACTERISTICS, V_{CC} = 5 V, T_A = 25°C

PARAMETER	FROM (INPUT)	TO (OUTPUT)	TEST CONDITIONS	XL/XD74LS279			UNIT
				MIN	TYP	MAX	
t _{PLH}	\bar{S}	Q	R _L = 2 kΩ, CL = 15 pF		12	22	ns
t _{PHL}					13	21	
t _{PHL}	\bar{R}	Q			15	27	ns

NOTE 3: Load circuits and voltage waveforms are shown in Section 1.

9. ORDERING INFORMATION

Ordering Information

Part Number	Device Marking	Package Type	Body size (mm)	Temperature (°C)	MSL	Transport Media	Package Quantity
XL74LS279	XL74LS279	SOP16	10.00 * 3.95	-0 to 70	MSL3	T&R	2500
XD74LS279	XD74LS279	DIP16	19.05 * 6.35	-0 to 70	MSL3	Tube 25	1000

10. DIMENSIONAL DRAWINGS

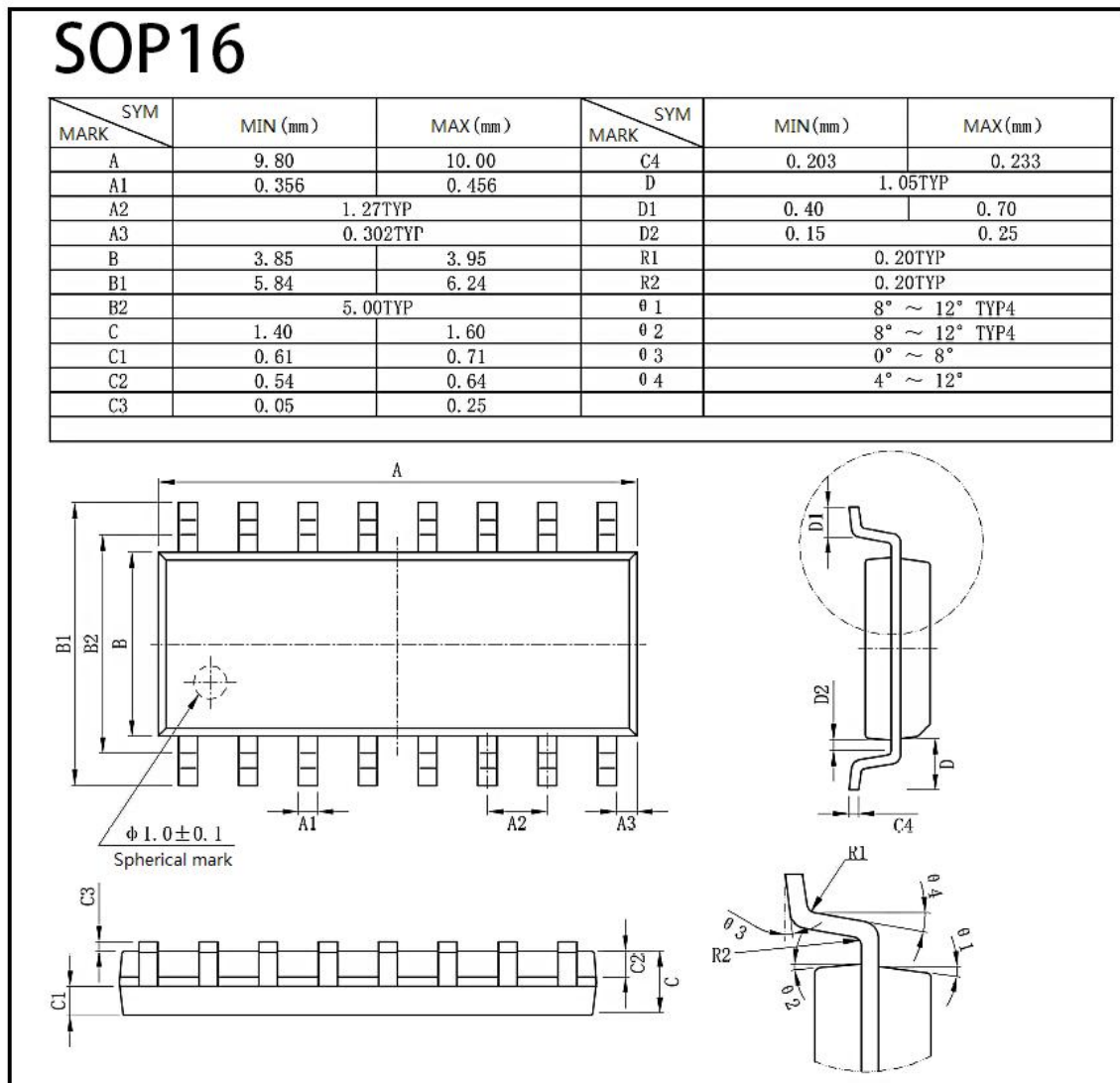

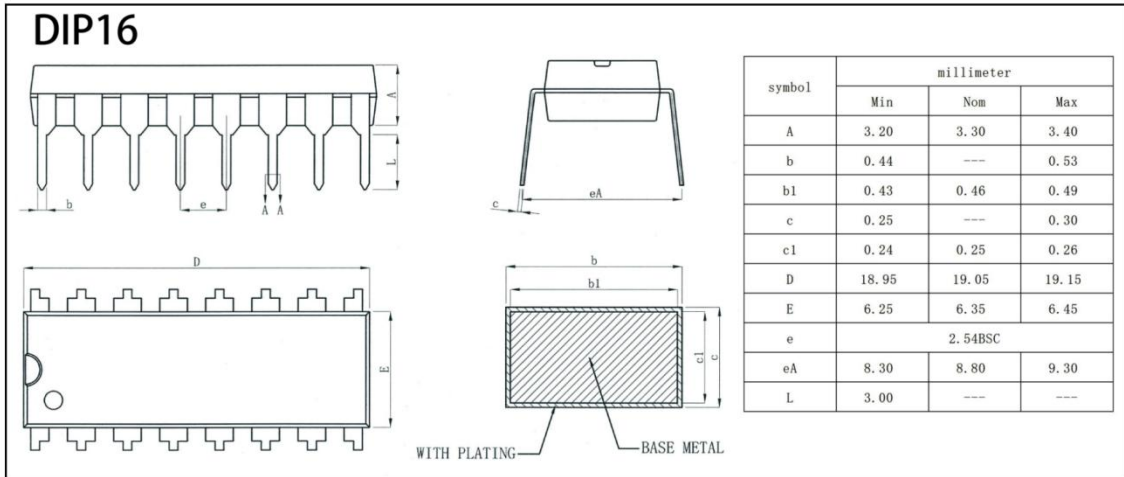

[if you need help contact us. Xinluda reserves the right to change the above information without prior notice]