

Specification of MEMS Microphone

RoHS Compliance & Halogen Free

LinkMems P/N: LMD3526T261-OAC03

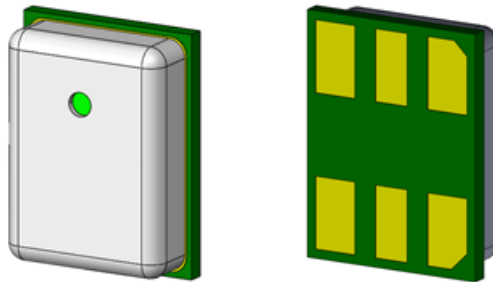

Designed by	Checked by	Approved by
Kevin	Thomas	Hary

Customer Approval

Approved by: _____



Contents

1. Introduction	3
2. Electrical Characteristics	3
3. Timing Characteristics	5
4. Frequency Response Curve	5
5. Test Setup	6
6. Measurement Circuit	6
7. Mechanical Characteristics	7
7.1. Weight	7
7.2. Appearance Drawing	7
8. Application	8
8.1. Pickup Tool Pick Location & PCB Solder Pad Layout	8
8.2. Recommended Reflow Process Condition	8
8.3. Storage Condition	8
9. Packaging	9
9.1. Tape & Reel Specification	9
9.2. Packaging Information	10
10. Reliability Test	11

MEMS Microphone

1. Introduction

The LMD3526T MEMS Microphones are integrated with specialized Pre-amplification ASIC to provide high sensitivity, high SNR output from a capacitive audio sensor. It's packaged for surface mounting and high temperature reflow assembly. Data format is a single bit PDM.

2. Electrical Characteristics

Test Condition: $V_{DD}=1.8V$, $23\pm 2^{\circ}C$, $55\pm 10\%R.H.$, unless otherwise specified.

Electrical Characteristics

Parameter	Symbol	Note/Test Condition	Values			Unit
			Min.	Typ.	Max.	
Power supply voltage	V_{DD}		1.62	1.8	3.6	V

Standard Mode

Test Condition: Measurement Clock Frequency 2.4 MHz, $V_{DD} = 1.8 V$

Specification	Symbol	Test Conditions	Min	Typ	Max	Unit
Directivity			Omni-directional			
Sensitivity Range	S	94dB SPL @1kHz	-27	-26	-25	dB
Current Consumption	I			750		μA
S/N Ratio	SNR	94dB SPL @1kHz BW=20-8kHz(A-Weighted)		62		dB(A)
		94dB SPL @1kHz BW=20-20kHz(A-Weighted)		61		dB(A)
Total Harmonic Distortion	THD	94dB SPL @1kHz			0.5	%
Acoustic Overload Point	AOP	10% THD @1kHz		120		dB SPL
Power Supply Rejection	PSR	100mVpp Square wave@217Hz, A-weighted		-90		dB

Low Power Mode

Test Condition: Measurement Clock Frequency 768 kHz, VDD = 1.8 V

Specification	Symbol	Test Conditions	Min	Typ	Max	Unit
Directivity			Omni-directional			
Sensitivity Range	S	94dB SPL @1kHz	-27	-26	-25	dB
Current Consumption	I			320		μA
S/N Ratio	SNR	94dB SPL @1kHz BW=20-8kHz(A-Weighted)		61		dB(A)
Total Harmonic Distortion	THD	94dB SPL @1kHz			0.5	%
Acoustic Overload Point	AOP	10% THD @1kHz		120		dB SPL
Power Supply Rejection	PSR	100mVpp Square wave@217Hz, A-weighted		-90		dB

Operation Ratings

Parameter	Symbol	Note/Test Condition	Vales			Unit
			Min	Typ.	Max	
Power supply voltage	V _{DD}		1.62		3.6	V
Frequency Range	Sleep Mode		0		50	kHz
	Low Power Mode		150	768	900	kHz
	Standard Mode		1000		4800	kHz
Duty Cycle	DC		45	50	55	%
Logic Input High			0.65*V _{DD}		V _{DD} +0.3	V
Logic Input Low			-0.3		0.35*V _{DD}	V
Logic Output High			V _{DD} -0.45			V
Logic Output Low					0.45	V
Load Capacitance					140	pF

3. Timing Characteristics

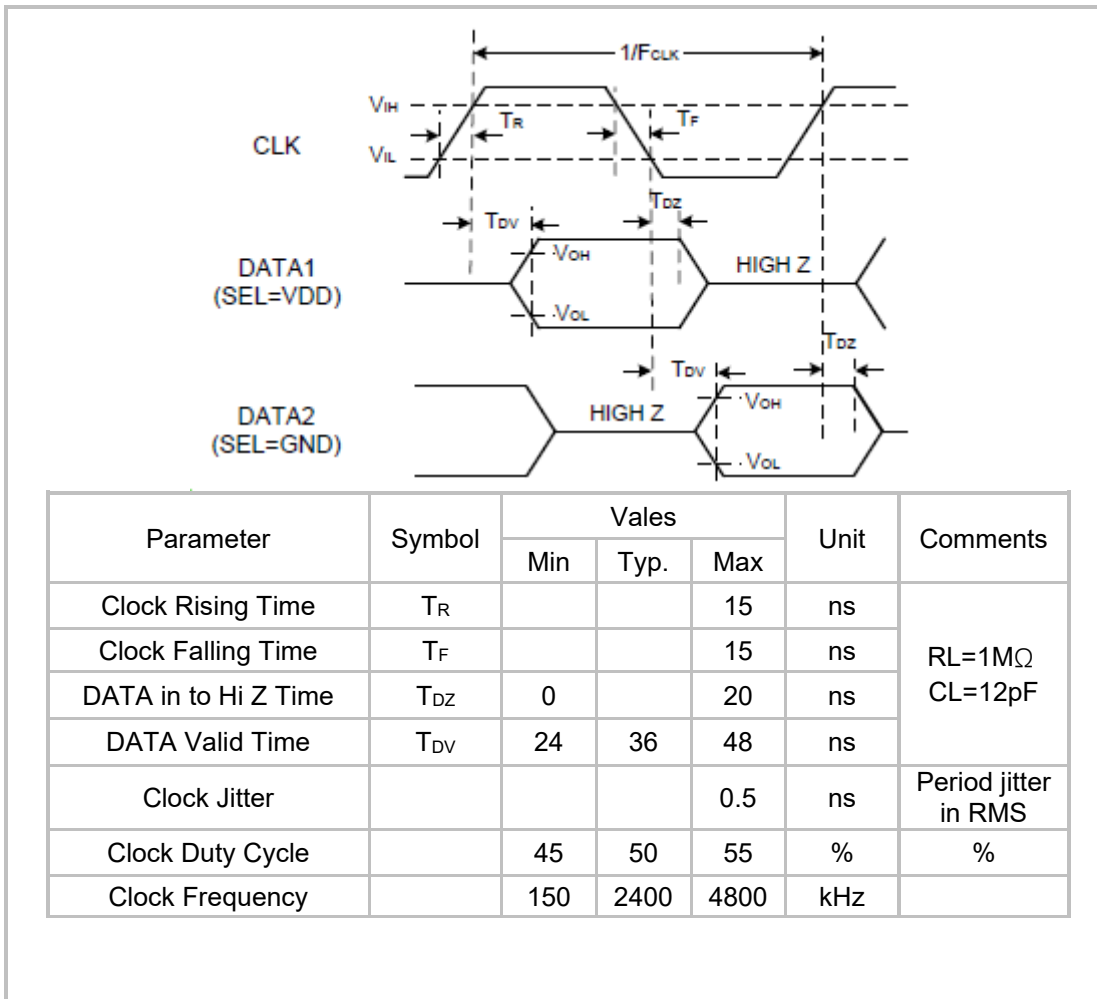

4. Frequency Response Curve

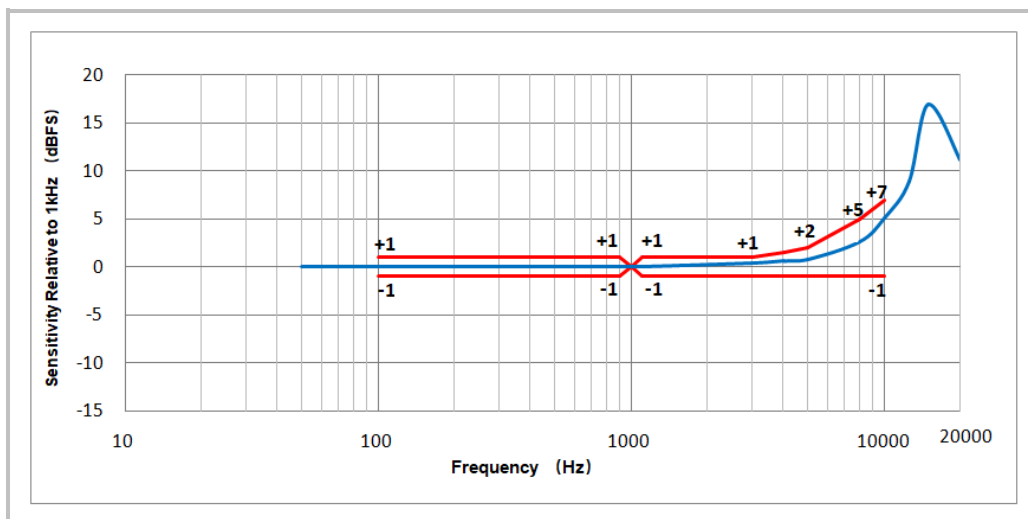

5. Test Setup (Sensitivity Test in Anechoic Room)

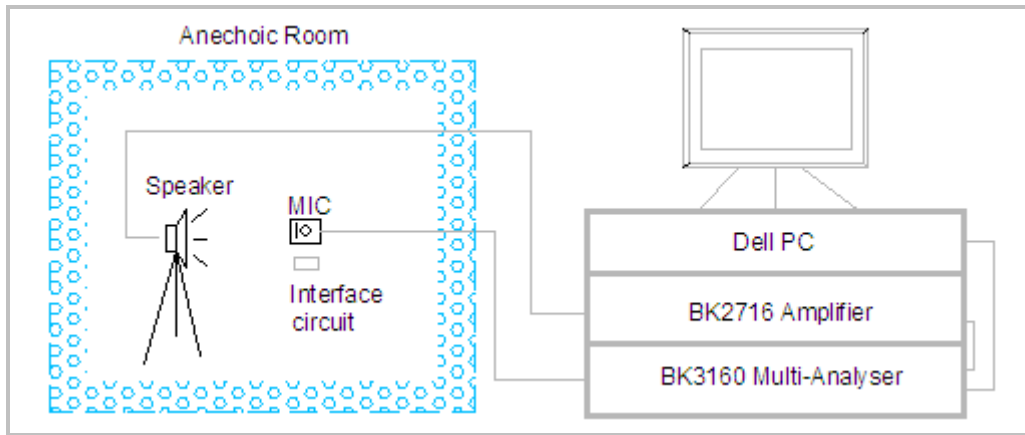

6. Measurement Circuit

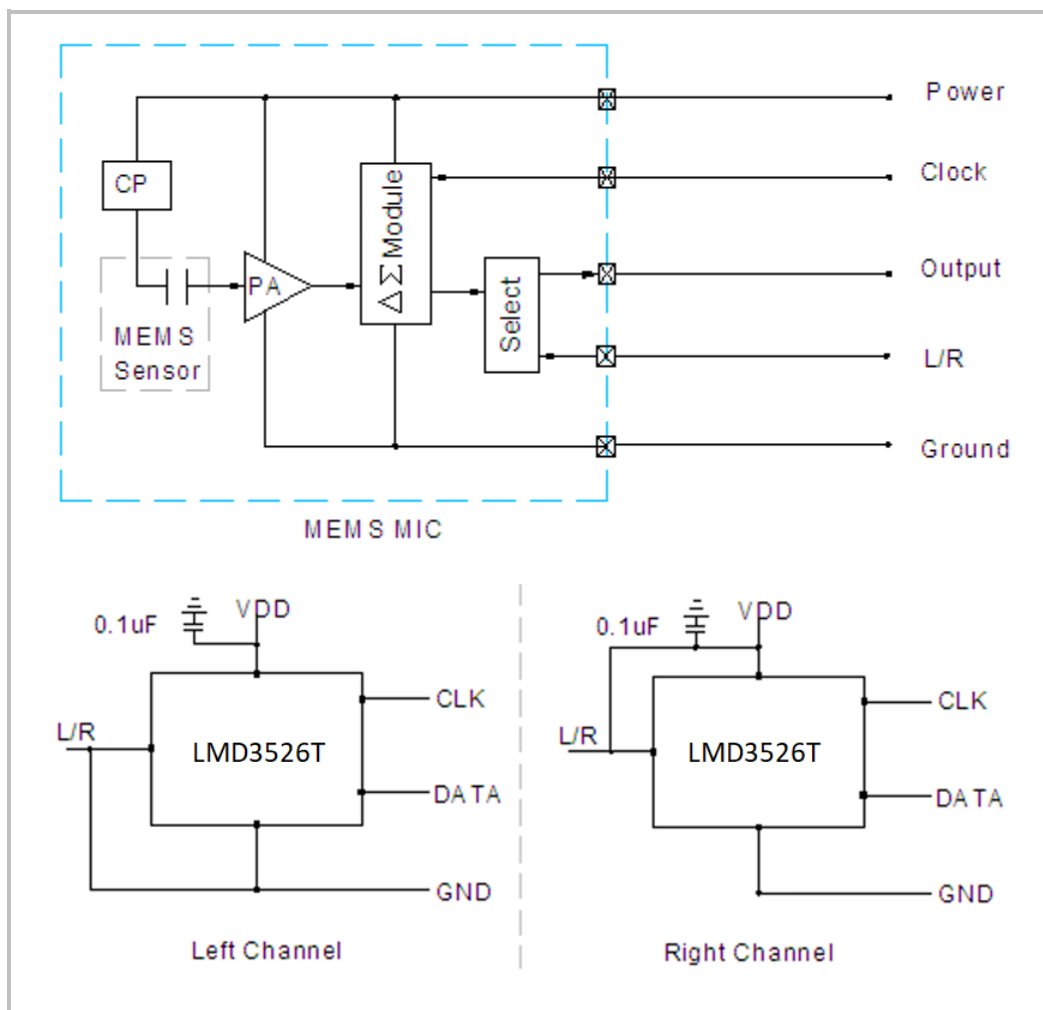

7. Mechanical Characteristics

7.1 Weight: Less than 0.03g

7.2 Appearance Drawing(unit: mm)

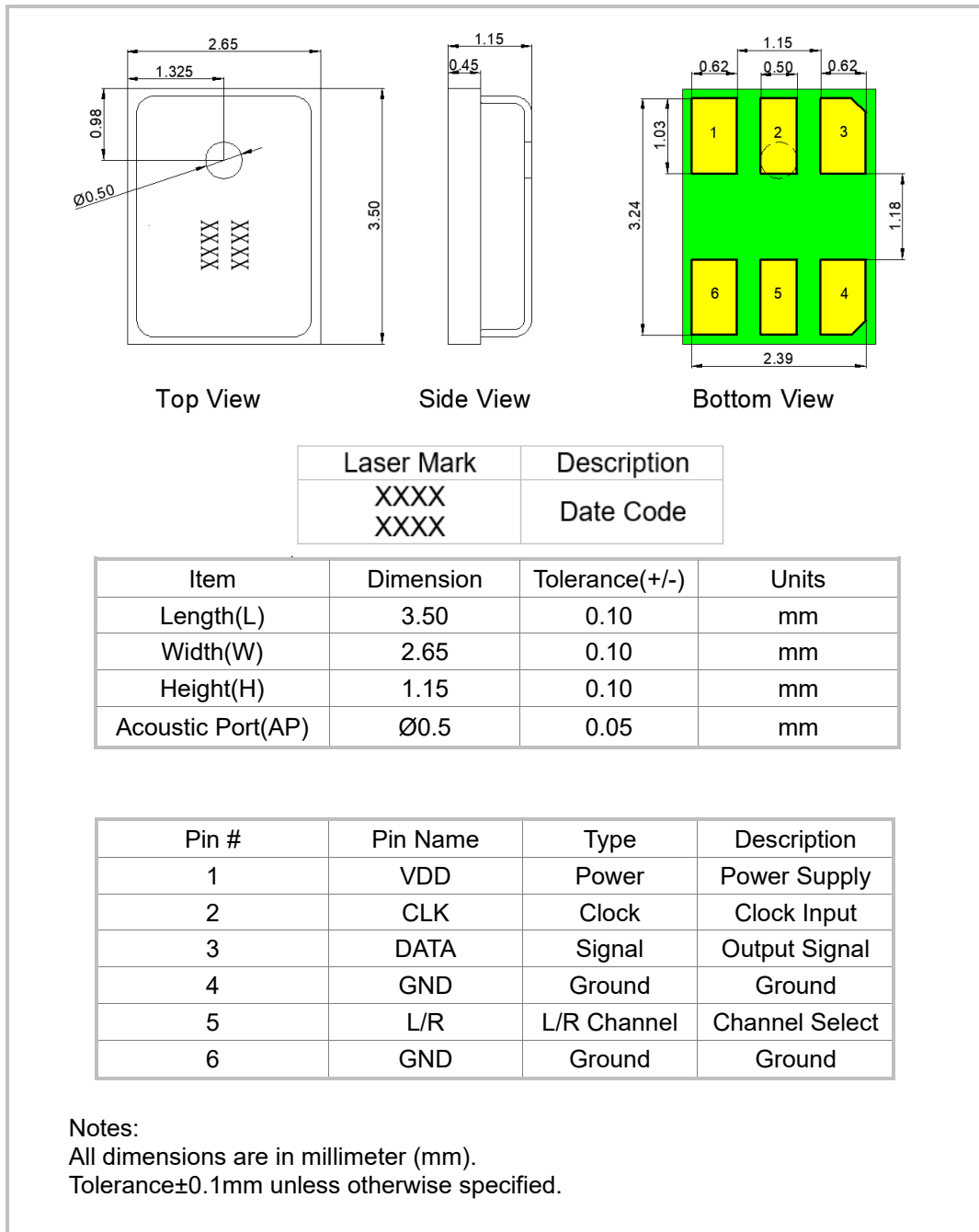

8. Application

8.1 Pickup Tool Pick Location & PCB Solder Pad Layout

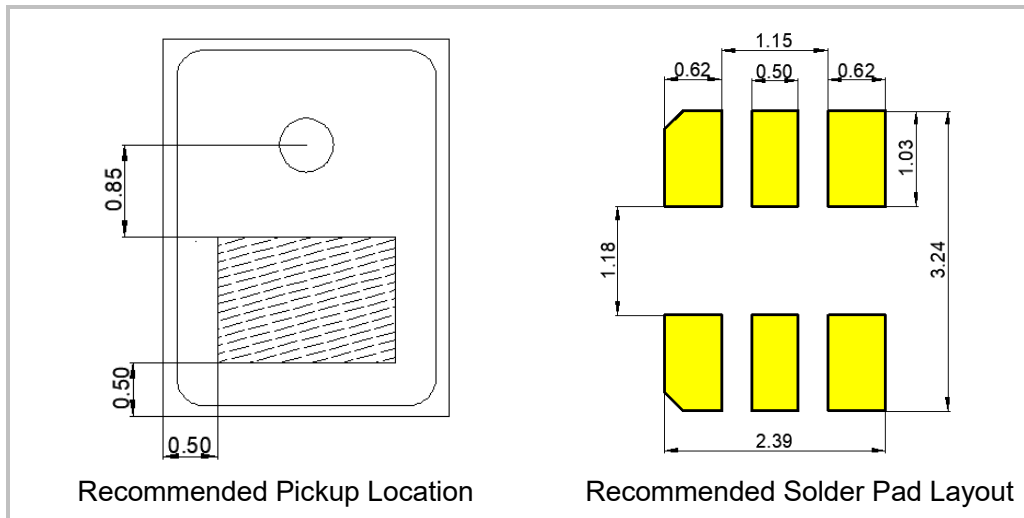

8.2 Recommended Reflow Process Condition

Recommend reflow profile, solder reflow $\leq 260^{\circ}\text{C}$ (for 30s Max of peak temperature).

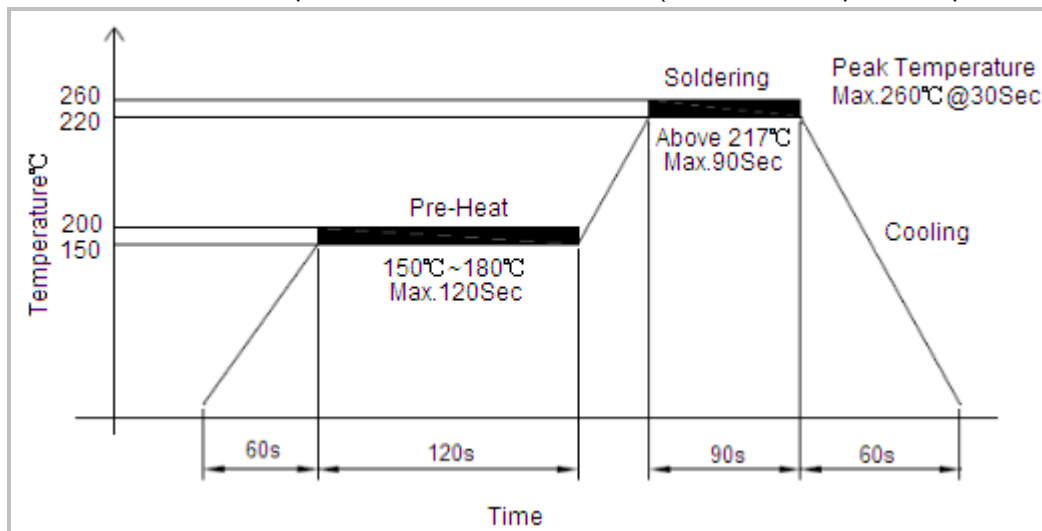

Important Notes

In order to minimize device damage:

1. Do not wash or clean the boards after the reflow process.
2. Do not apply the airflow which pressure over 0.3MPa blow into the port hole within a distance of less than 5 cm.
3. Do not exposed to ultrasonic processing or cleaning.
4. Do not pull a vacuum over port hole of the microphone.

8.3 Storage Condition

8.3.1 Storage temperature range: $-40^{\circ}\text{C} \sim +100^{\circ}\text{C}$, and humidity is less than 75%.

8.3.2 Operating temperature range: $-40^{\circ}\text{C} \sim +85^{\circ}\text{C}$.

8.3.3 MSL (moisture sensitivity Level) is Class 1.

9. Packaging

9.1 Tape & Reel Specification

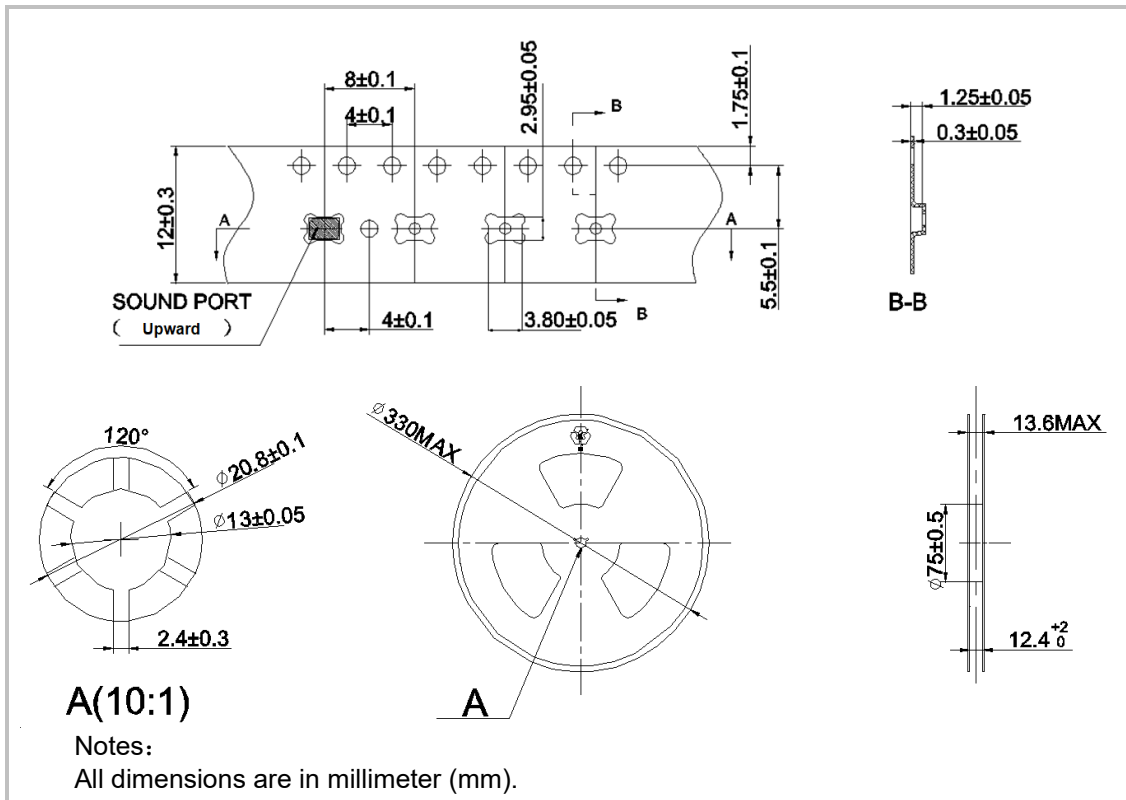

9.2 Packaging Information

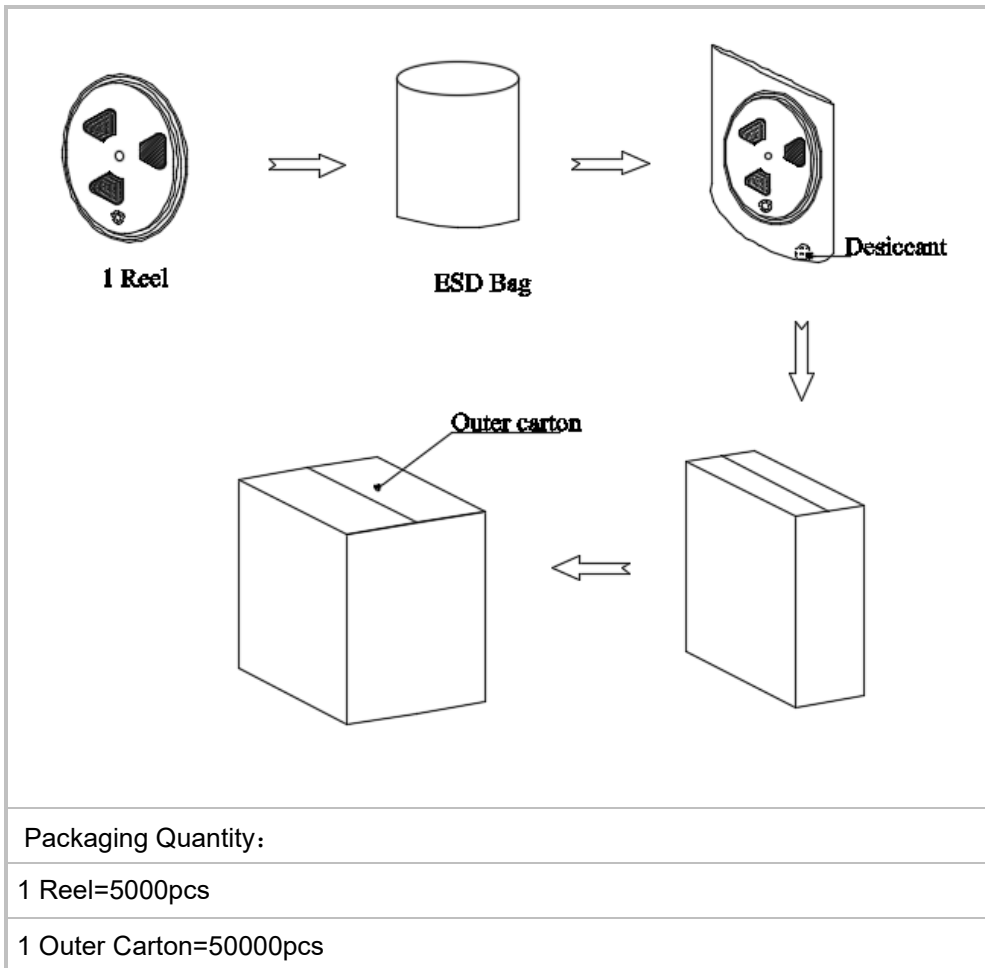

10. Reliability Test

The samples should be placed in the room with 23+/-2°C, 55+/-10%R.H. for 2 hours at least before final measurement, unless otherwise specified.

Item	Detail	Standard
Simulated Reflow (Without Solder)	Samples for qualification testing require 3 times 260±5°C reflow solder profiles. 2 hours of setting time is required between each reflow profile test.	±3 dB
Static Humidity	Precondition at +25°C for 1 hour. Then expose to +85°C with 85% relative humidity for 240 hours.	±3 dB
Temperature Shock	Each cycle shall consist of 30 minutes at -40°C, 30 minutes at +125°C with 5 minutes transition time. Test duration is for 30 cycles, starting from cold to hot temperature.	±3 dB
ESD Sensitivity	According to MIL-STD-883G, Method 3015.7 for Human Body Model. Discharge Position: I/O pins Charge Voltage: ±3000V Discharge Network: 100pF & 1500Ω	±3 dB
Random Vibrations	Vibrate randomly along three perpendicular directions for 30 minutes in each direction, 4 cycles from 20Hz~2000Hz with a peak acceleration 20g.	±3 dB
Mechanical Shock	Subject samples to half sine shock pulses (3000g±15% for 0.3ms) in each direction, totally 18 shocks.	±3 dB
High temperature Storage	Microphone unit must maintain sensitivity after storage at +105°C for 240 hours.	±3 dB
Low temperature Storage	Microphone unit must maintain sensitivity after storage at -40°C for 240 hours.	±3 dB
Drop Test	The test was repeated in six directions for 3 times, Dropped from 1.5m height on to a steel surface, total 18 times and inspected for mechanical damage.	±3 dB

