

General Description

The D1509 is a monolithic IC designed for a step-down DC/DC converter and own the ability of driving a 2A load without additional transistor. It saves board space. The external shutdown function can be controlled by logic level and then come into standby mode. The internal compensation makes feedback control having good line and load regulation without external design. Regarding protected function, thermal shutdown is to prevent over temperature operating from damage, and current limit is against over current operating of the output switch. If current limit function occurs and V_{FB} is down below 0.5V, the switching frequency will be reduced. The D1509 operates at a switching frequency of 150KHz thus allow smaller sized filter components than what would be needed with lower frequency switching regulators. Other features include a guaranteed $\pm 4\%$ tolerance on output voltage under specified input voltage and output load conditions, and $\pm 15\%$ on the oscillator frequency. The output version included fixed 3.3V, 5V, 12V, and an adjustable type. The chips are available in a standard SOP8 and ESOP8 package.

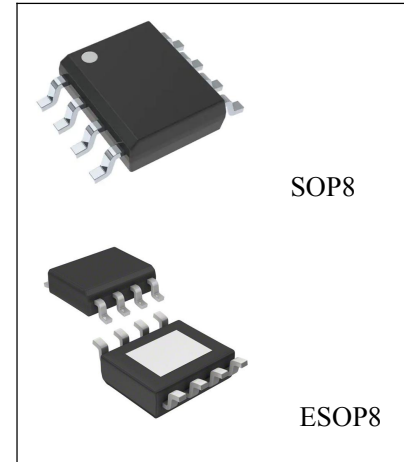

Features

- 3.3V, 5V, 12V and Adjustable Output Version
- Output Adjustable Voltage From 1.23V to 37V
- Fixed 150KHz Switching Frequency
- Voltage Mode Non-synchronous PWM Control
- Thermal-Shutdown and Current-Limit Protection
- ON/OFF Shutdown Control Input
- Wide 4.5V to 40V Input Voltage Range
- Output Load Current: 2A
- Low Power Standby Mode
- Built-in Switching Transistor on Chip

Package Information

Part NO.	Package Description	Package Marking	Package Option
D1509-3.3(F)	SOP8	CHMC D1509 33 XXX	100/Tube 4000/Reel
D1509-5.0(F)	SOP8	CHMC D1509 50 XXX	100/Tube 4000/Reel
D1509-12(F)	SOP8	CHMC D1509 12 XXX	100/Tube 4000/Reel
D1509-ADJ(F)	SOP8	CHMC D1509 AD XXX	100/Tube 4000/Reel
D1509-3.3(E)	ESOP8	CHMC D1509 33 XXX	100/Tube 4000/Reel
D1509-5.0(E)	ESOP8	CHMC D1509 50 XXX	100/Tube 4000/Reel
D1509-12(E)	ESOP8	CHMC D1509 12 XXX	100/Tube 4000/Reel
D1509-ADJ(E)	ESOP8	CHMC D1509 AD XXX	100/Tube 4000/Reel

CHMC:Trademark D1509:Part NO. 33(3.3V)/50(5.0V)/12(12V)/AD(ADJ):Output Voltage
 XXX:Lot NO.

Application

- Simple High-Efficiency Step-down Regulator
- On-card Switching Regulators
- Positive to Negative Converter

Pin Configuration

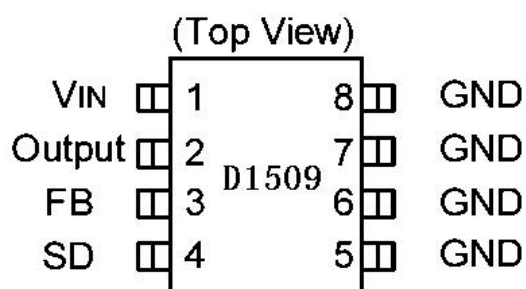

Pin Descriptions

Name	Description
V _{IN}	Supply Voltage Input
Output	Power Switching Output
GND	Ground
FB	Output Voltage Feedback Control
SD	ON/OFF Shutdown

Block Diagram

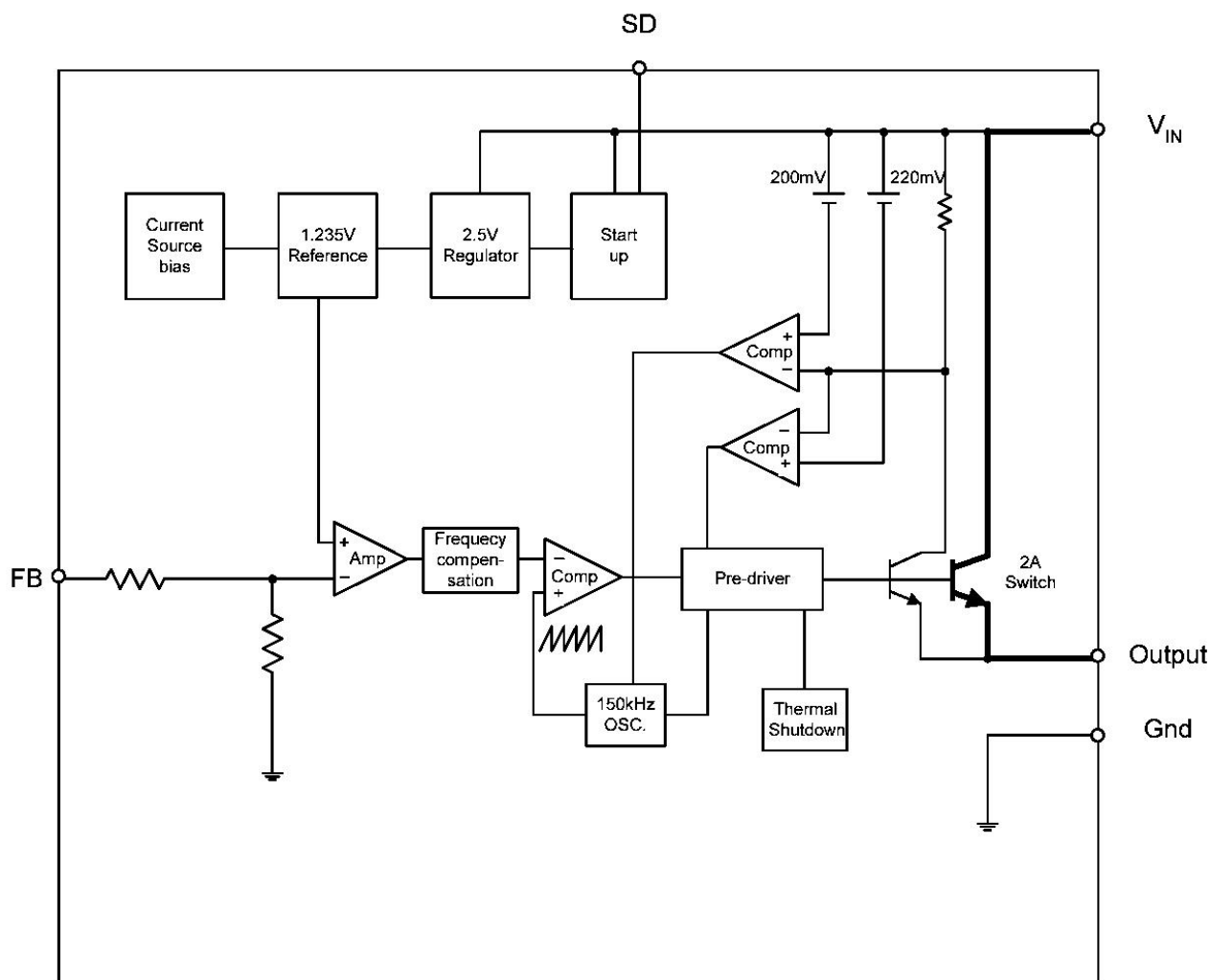

Absolute Maximum Ratings

Characteristics	Symbol	Value	Unit
Supply Voltage	V_{IN}	+42	V
ON/OFF pin input voltage	V_{SD}	-0.3 ~ V_{IN}	V
Feedback pin voltage	V_{FB}	-0.3 ~ V_{IN}	V
Output voltage to ground	V_{OUT}	-1	V
Power dissipation	PD	Internally limited	W
Storage temperature	T_{stg}	-65 ~ +150	°C
Operating temperature	T_{opr}	-40 ~ +125	°C
Operating voltage	V_{OP}	+4.5 ~ +40	V

Electrical Characteristics

(Refer to the test circuit, $V_{IN}=12V$ for 3.3V, 5V, adjustable version and $V_{IN}=24V$ for the 12V version, $I_{LOAD}=0.5A$)

Characteristics	Symbol	Test Conditions	Min	Typ	Max	Unit
Feedback Bias Current	I_{FB}	$V_{FB}=1.3V$ (Adjustable version only)		50	100	nA
Oscillator Frequency	Fosc		127	150	173	kHz
Saturation Voltage	V_{SAT}	$I_{OUT}=2A$, No outside circuit $V_{FB}=0V$ force driver on		1.2	1.5	V
Max. Duty Cycle(ON)	DC	$V_{FB}=0V$ force driver on	93	98		%
Min. Duty Cycle(OFF)		$V_{FB}=12V$ force driver off		0		
Current Limit	I_{CL}	Peak current, No outside circuit $V_{FB}=0V$ force driver on	3.0	4.0		A
Output Leakage Current (Output=0)	I_L	No outside circuit $V_{FB}=12V$ force driver off			2	mA
Output Leakage Current (Output=-1)		$V_{IN}=40V$		5	20	mA
Quiescent Current	I_Q	$V_{FB}=12V$ force driver off		5	10	mA
Standby Quiescent Current	I_{STBY}	ON/OFF pin=5V $V_{IN}=40V$		50	200	μA
ON/OFF pin Logic Input Threshold Voltage	V_{IL}	Low(regulator ON)			0.6	V
	V_{IH}	High(regulator OFF)	2.0			
ON/OFF pin Logic Input Current	I_H	$V_{LOGIC}=5.0V$ (OFF)		12	30	μA
ON/OFF pin Input Current	I_L	$V_{LOGIC}=0.5V$ (ON)		0	10	
Thermal Resistance	Θ_{JC}	Junction to case		15		$^{\circ}C/W$
Thermal Resistance with Copper Area of Approximately 3 in ²	Θ_{JA}	Junction to ambient		70		$^{\circ}C/W$
D1509-3.3						
Output Voltage	V_{OUT}	$4.75V \leq V_{IN} \leq 40V$ $0.2A \leq I_{LOAD} \leq 2A$	3.168	3.300	3.432	V
Efficiency	η	$V_{IN}=12V, I_{LOAD}=2A$		76		%
D1509-5.0						
Output Voltage	V_{OUT}	$7V < V_{IN} < 40V$ $0.2A \leq I_{LOAD} \leq 2A$	4.80	5.00	5.20	V
Efficiency	η	$V_{IN}=12V, I_{LOAD}=2A$		83		%
D1509-12						
Output Voltage	V_{OUT}	$15V \leq V_{IN} \leq 40V$ $0.2A \leq I_{LOAD} \leq 2A$	11.52	12.00	12.48	V
Efficiency	η	$V_{IN}=25V, I_{LOAD}=2A$		90		%

Continue:

Characteristics	Symbol	Test Conditions	Min	Typ	Max	Unit
D1509-ADJ						
Output Feedback	V_{FB}	$4.5V \leq V_{IN} \leq 40V$ $0.2A \leq I_{LOAD} \leq 2A$ V_{OUT} programmed for 3V	1.193	1.230	1.267	V
Efficiency	η	$V_{IN}=12V, I_{LOAD}=2A$		74		%

Function Description

Pin Function +V_{IN}

This is the positive input supply for the IC switching regulator. A suitable input bypass capacitor must be presented at this pin to minimize voltage transients and to supply the switching currents needed by the regulator.

Ground

Circuit ground.

Output

Internal switch. The voltage at this pin switches between (+V_{IN} - V_{SAT}) and approximately - 0.5V, with a duty cycle of approximately V_{OUT} / V_{IN}. To minimize coupling to sensitive circuitry, the PC board copper area connected to this pin should be minimized.

Feedback

Senses the regulated output voltage to complete the feedback loop.

SD

Allows the switching regulator circuit to be shutdown using logic level signals thus dropping the total input supply current to approximately 150uA. Pulling this pin below a threshold voltage of approximately 1.3V turns the regulator on, and pulling this pin above 1.3V (up to a maximum of V_{IN}) shuts the regulator down. If this shutdown feature is not needed, the SD pin can be wired to the ground pin.

Application Circuit

Fixed Type Circuit

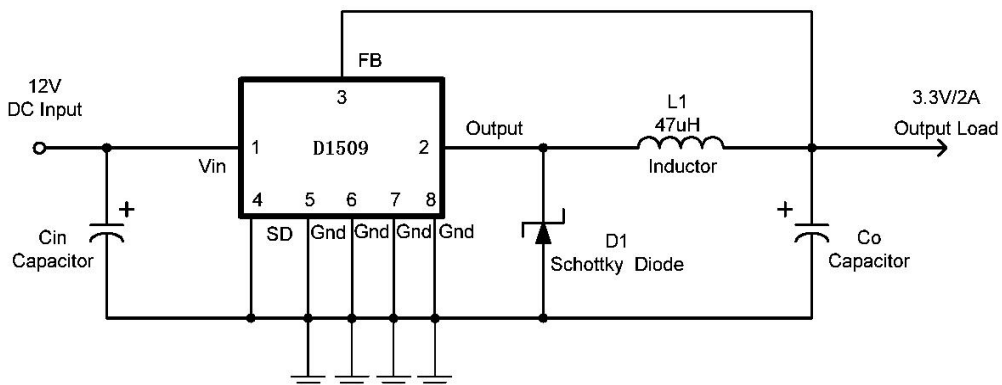

Adjustable Type Circuit

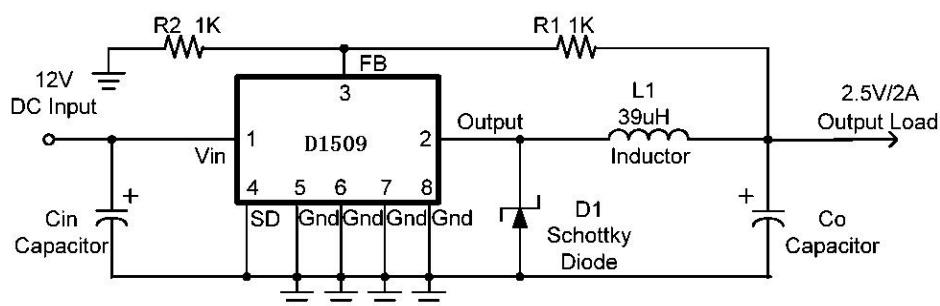

$$V_{out} = V_{FB} \times \left(1 + \frac{R1}{R2}\right)$$

$$V_{FB} = 1.23V$$

$$R2 = 1K \sim 3K$$

Delay Start Circuit

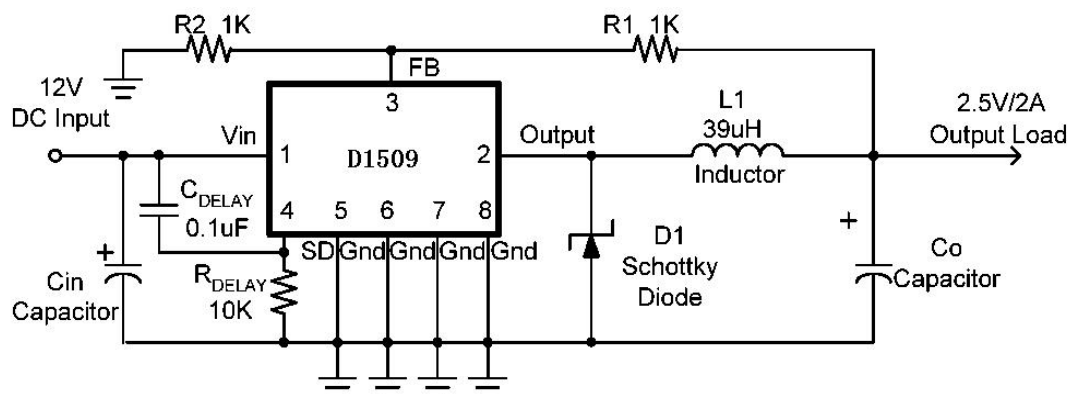

Outline Dimensions

ESOP8		Unit: mm		
Symbol	Dimensions In Millimeters		Dimensions In Inches	
	Min	Max	Min	Max
A	1.350	1.700	0.053	0.067
A1	0.050	0.200	0.002	0.008
A2	1.300	1.500	0.051	0.059
b	0.356	0.456	0.014	0.018
c	0.203(BSC)		0.009	
D	4.800	5.000	0.188	0.197
D1	3.302(REF)		0.130	
E	3.800	4.000	0.149	0.157
E1	5.800	6.200	0.228	0.244
E2	2.413(REF)		0.095	
e	1.270(BSC)		0.050	
L	0.400	0.600	0.015	0.023
θ	0°	6°	0°	6°

SOP8

Unit:mm

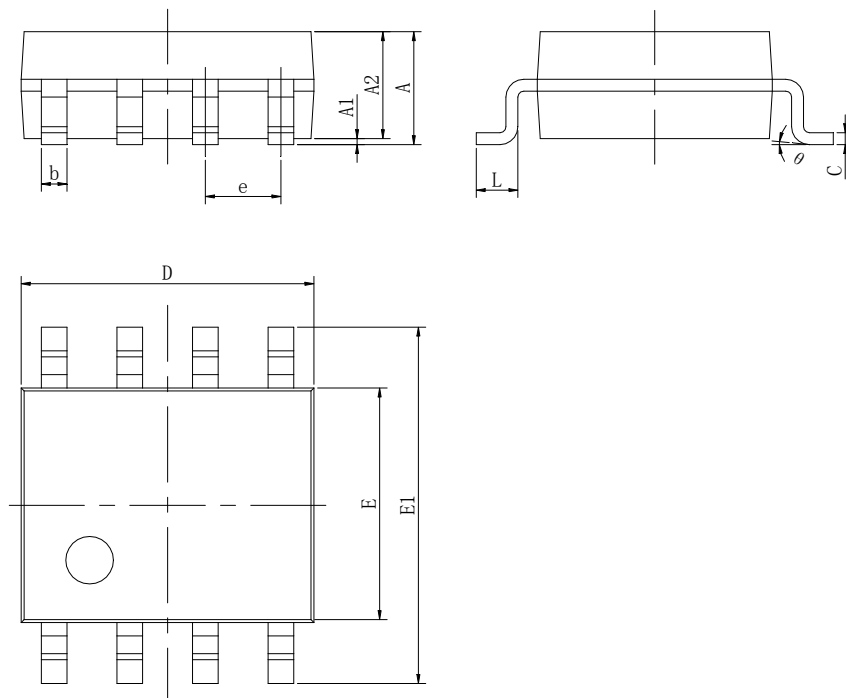

Symbol	Dimensions In Millimeters		Dimensions In Inches	
	Min	Max	Min	Max
A	1.350	1.800	0.053	0.071
A1	0.000	0.250	0.000	0.010
A2	1.250	1.550	0.053	0.061
b	0.300	0.510	0.011	0.020
c	0.170	0.250	0.006	0.010
D	4.700	5.100	0.185	0.201
E	3.800	4.000	0.150	0.157
E1	5.800	6.300	0.228	0.244
e	1.270(BSC)		0.050(BSC)	
L	0.400	1.270	0.016	0.050
θ	0°	8°	0°	8°

Statements

- Silicore Technology reserves the right to make changes without further notice to any products or specifications herein. Before customers place an order, customers need to confirm whether datasheet obtained is the latest version, and to verify the integrity of the relevant information.
- Failure or malfunction of any semiconductor products may occur under particular conditions, customers shall have obligation to comply with safety standards when customers use Silicore Technology products to do their system design and machine manufacturing, and take corresponding safety measures in order to avoid potential risk of failure that may cause personal injury or property damage.
- The product upgrades without end, Silicore Technology will wholeheartedly provide customers integrated circuits that have better performance and better quality.