

SCHMATIC (SHORTING)

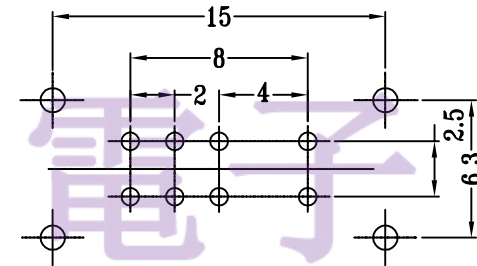
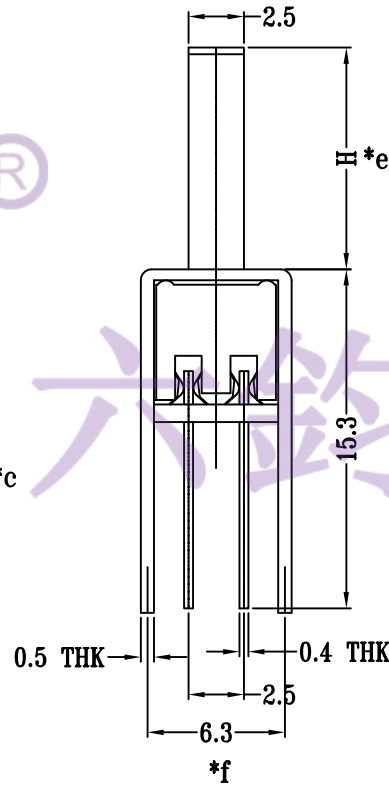
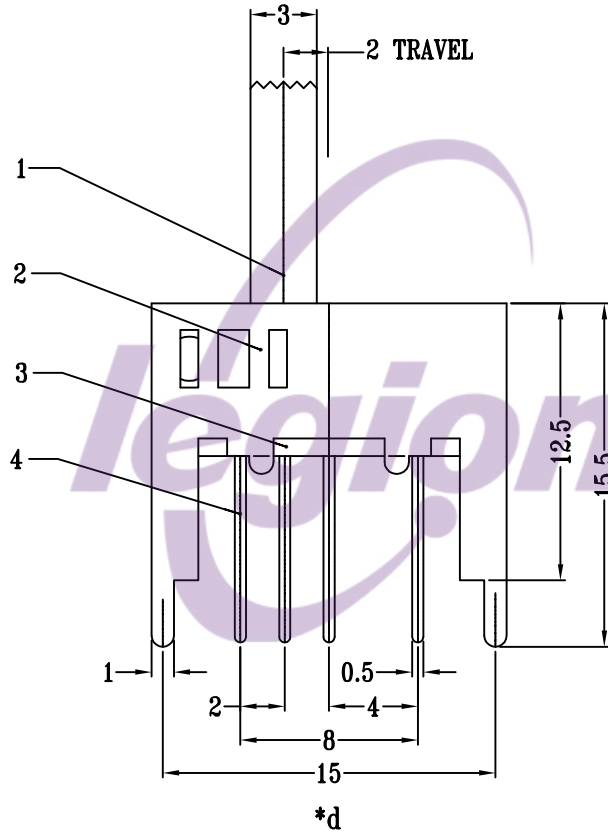

P.C.B LAYOUT
BOTTOM VIEW

H = 6 mm

8					TOLERANCE UNLESS SPECIFIED								
7	STEEL BALL	STELL	1	NATURAL	UP TO 5mm: ±0.1	ANGULAR							
6	SPRING	STEEL WIRE	1	NATURAL	ABOVE 5mm: ±0.2	±1°							
5	CONTACT CLIP	PBS STRIP	2	Ag CLAD			NO	DATE	REVISIONS		BY	APPD	
4	TERMINAL	BRASS STRIP	8	Ag PLATED	TITLE: VERTICAL SLIDE SWITCH			UNIT : MM	ROHS	DWN			
3	BASE	PHENOLIC RESIN	1	NATURAL	MODEL: SS-23D24G6			SCALE: 1:1	COMPLIANT	CHK'D			
2	FRAME	STEEL STRIP	1	Ni PLATED	东莞市六钧电子五金有限公司							APPD	
1	KNOB	POM	1	BLACK								PRO.AGL:	
NO.	PART NAME	MATERIAL	QTY	FINISHING									